

SBC60A5

REV HISTORY

REV	Name	DATE	DESIGNER	INSTRUCTION
1.0	SBC60A5 SCH 130500-130601	2013.06.01		Initial Version
2.0	SBC60A5 SCH 130501-140606	2014.06.06		Release Version

INDEX

PAGE	SCHEMATIC
01	REV HISTORY
02	BLOCK DIAGRAM
03	POWER & LED
04	SAMA5D3x-I & POWER
05	SAMA5D3x-II & NAND
06	SAMA5D3x-III & DATA
07	4Gb DDR2
08	GigaBit Ethernet
09	SD & eMMC
10	LCD
11	AUDIO & Buzzer & KEY
12	USB & GPIO & SPI & IIC & AD
13	USART & RS485 & CAN

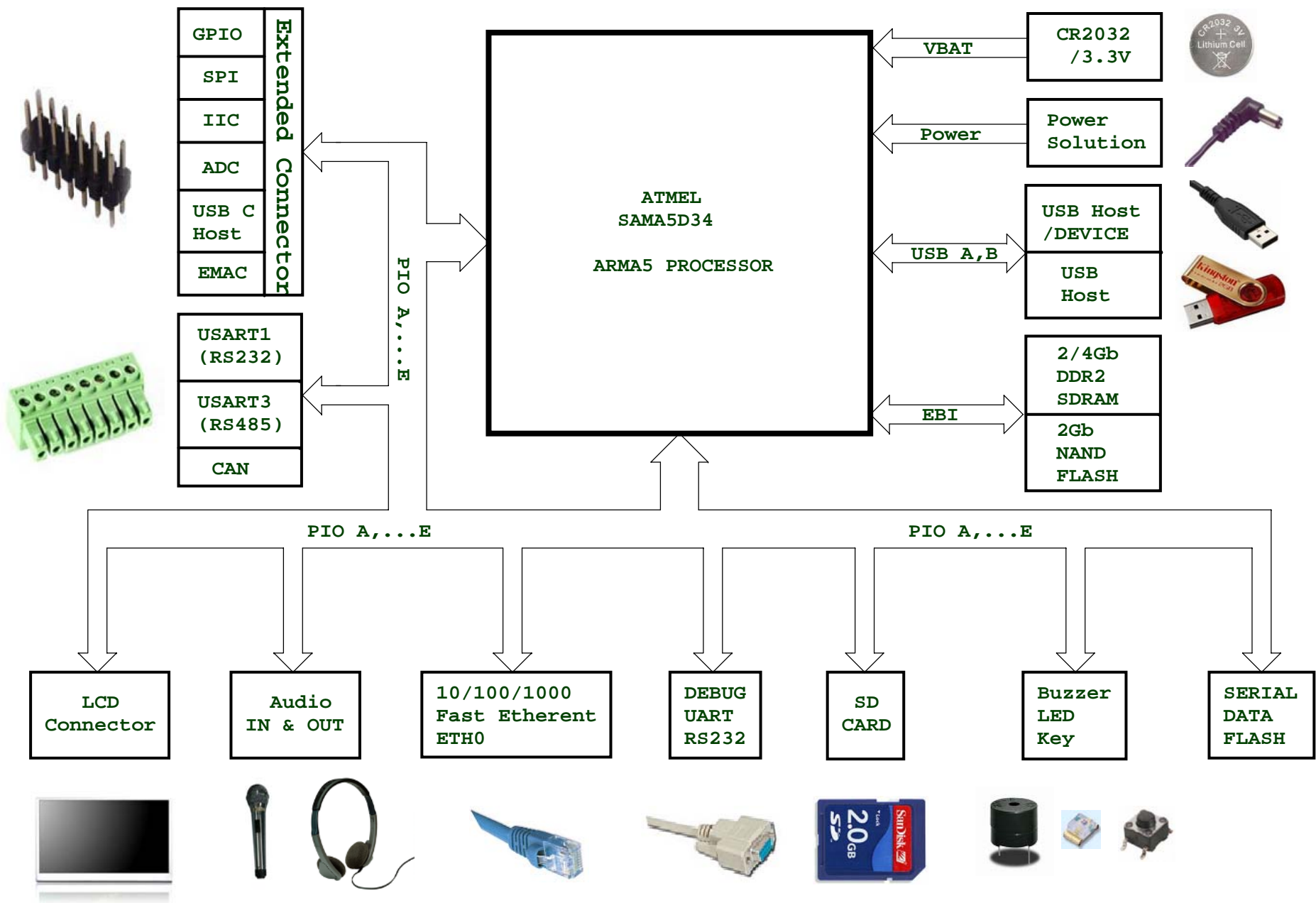

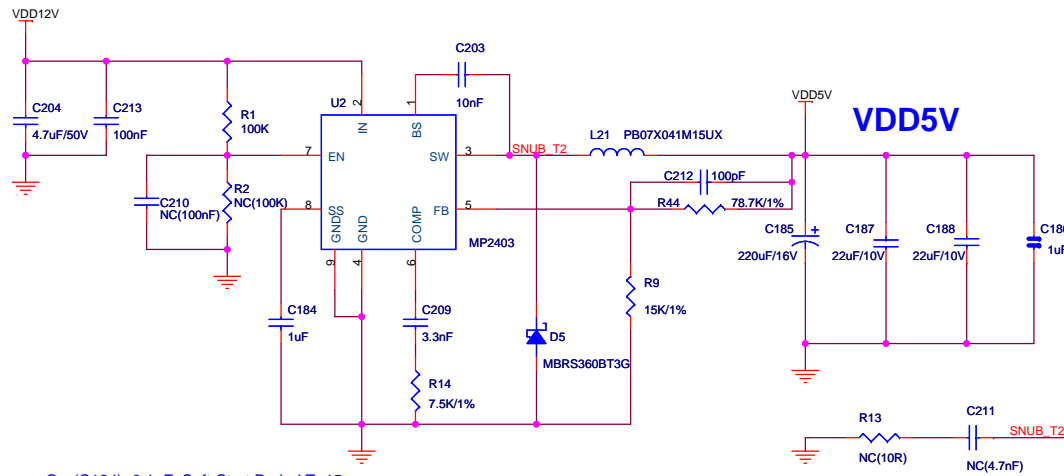
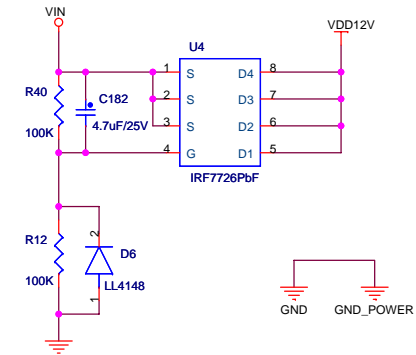
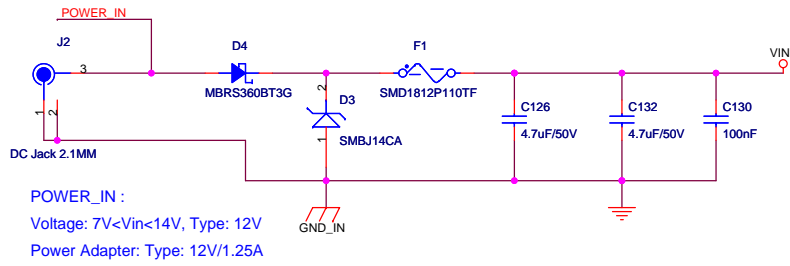

Css(C184)=0.1uF: Soft-Start Period $T=15ms$
 Css(C184)=1uF: Soft-Start Period $T=(1uF/0.1uF)*15ms=150ms$

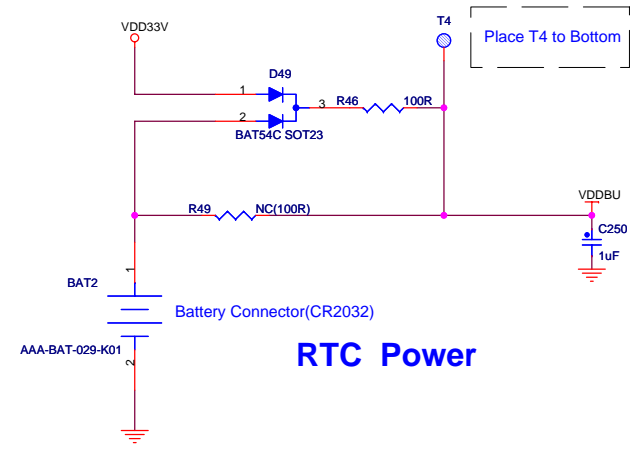

RTC Power

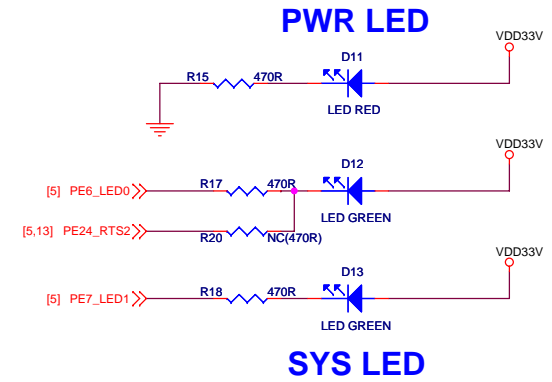

SYS LED

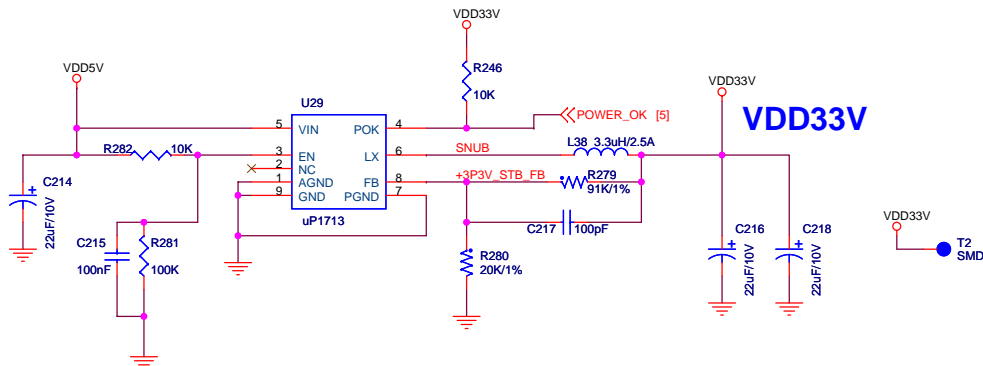

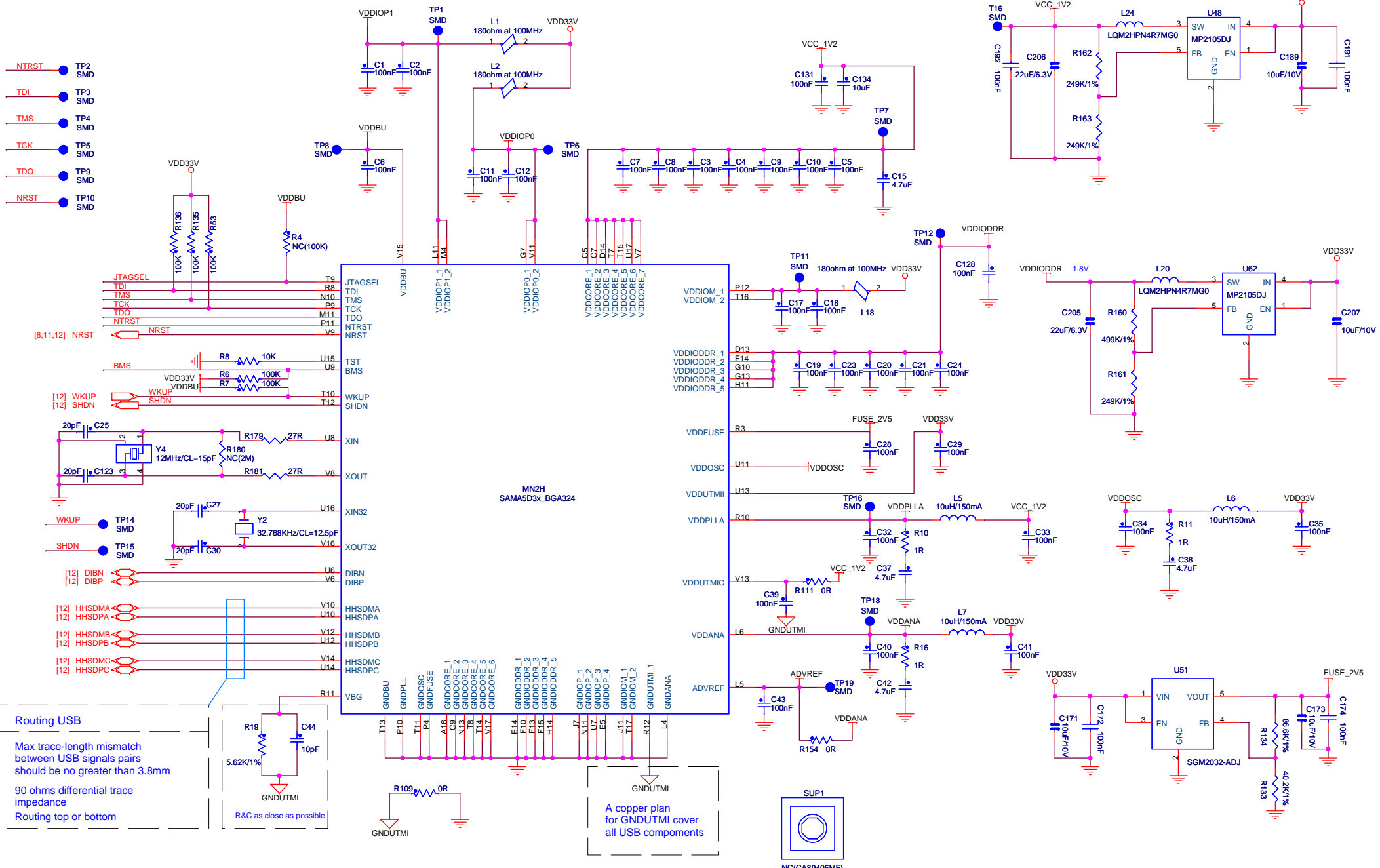

Routing USB

Max trace-length mismatch between USB signals pairs should be no greater than 3.8mm
 90 ohms differential trace impedance
 Routing top or bottom

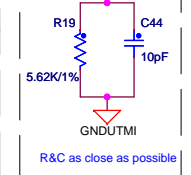

R&C as close as possible



A copper plan for GNDUTMI cover all USB components

		http://www.embest-tech.com	
		Title: SBC60A5	
Size: A3	Document Number: 04) SAMASD3x-I & POWER	Rev: 130501	
Draw By: ASSP	Date: Monday, April 14, 2014	Sheet: 4 of 13	

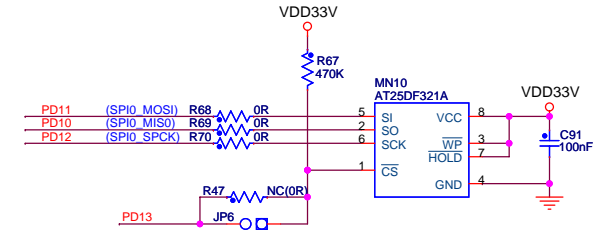
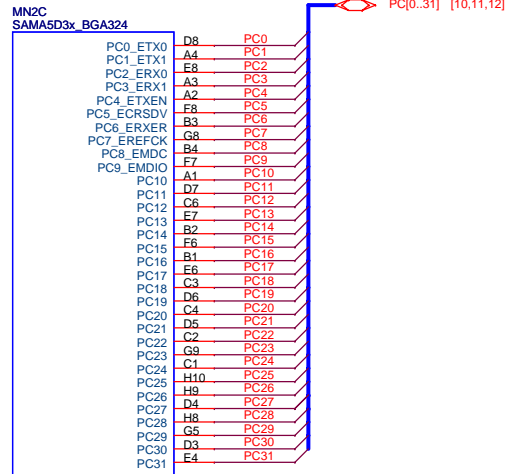
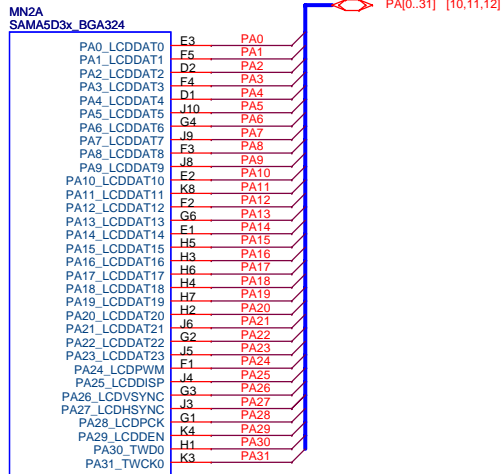

SPI DATAFLASH

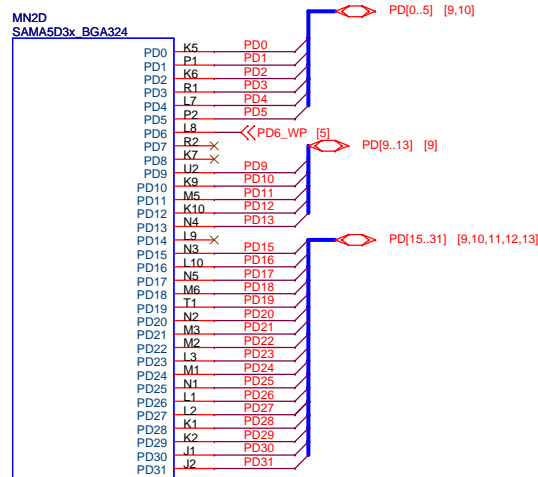
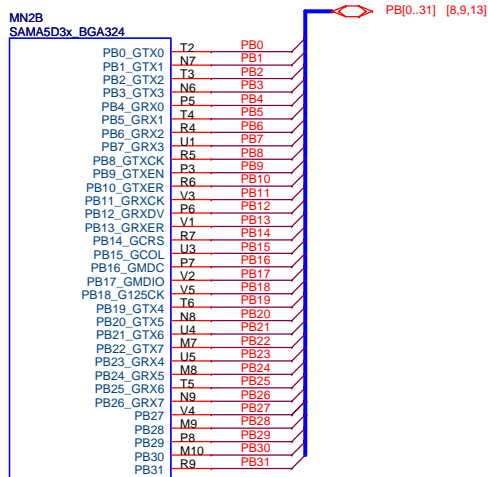

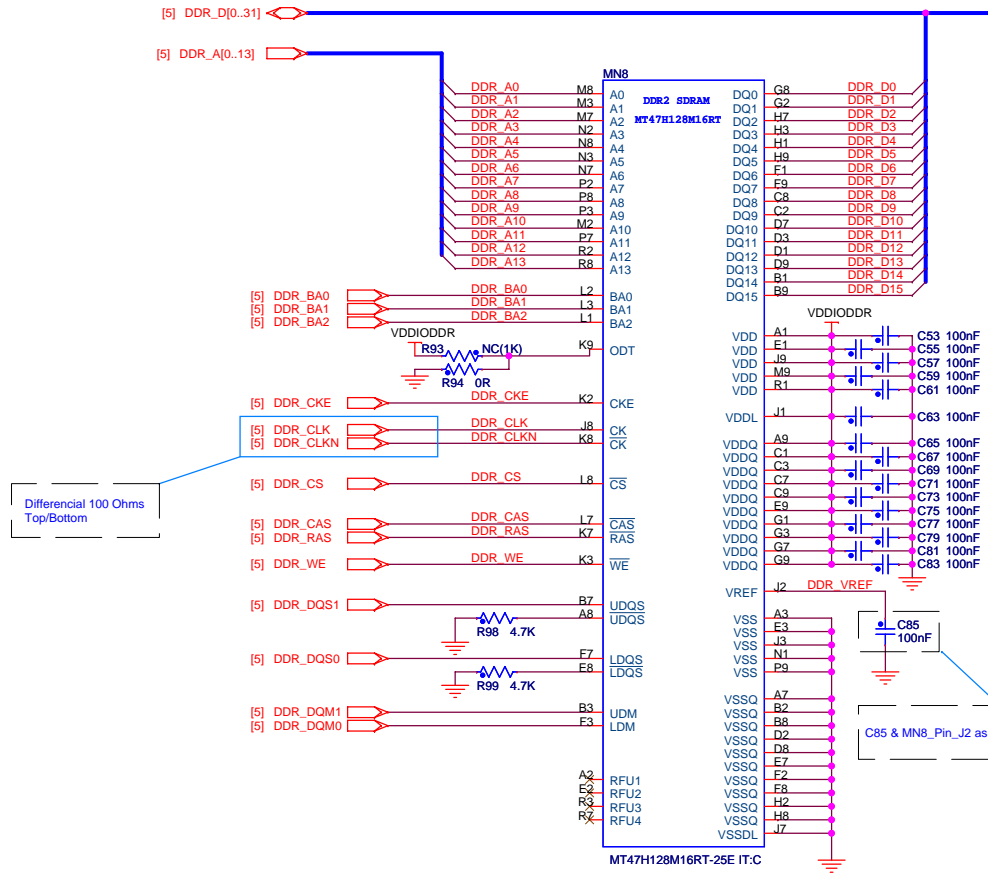

DDR2 SDRAM

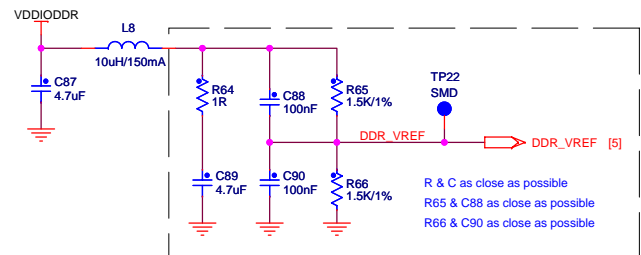
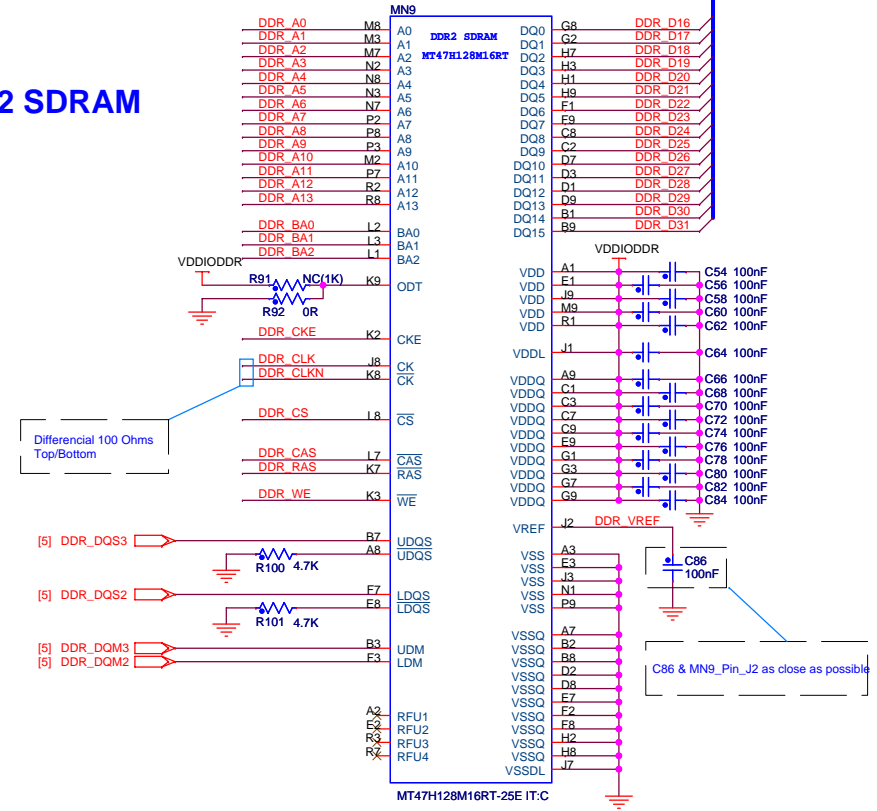

Keep nets as short as possible, therefore, DDR2 devices have to be placed close as possible of SAM5D3X. The layout EBI DDR2 should use controlled impedance traces of ZO=50ohm characteristic impedance.

Address, control and data traces may not exceed 1.3 inches (33.0 mm).
 Address, control and data traces must be length-matched to within 0.1 inch (2.54mm).
 Address, control and data traces must match the data group trace lengths to within 0.25 inches (6.35mm).

		http://www.embest-tech.com	
		Title: SBC60A5	
Size: A3	Document Number: 07) 4Gb DDR2	Rev: 130501	
Draw By: ASSP	Date: Monday, April 14, 2014	Sheet: 7 of 13	

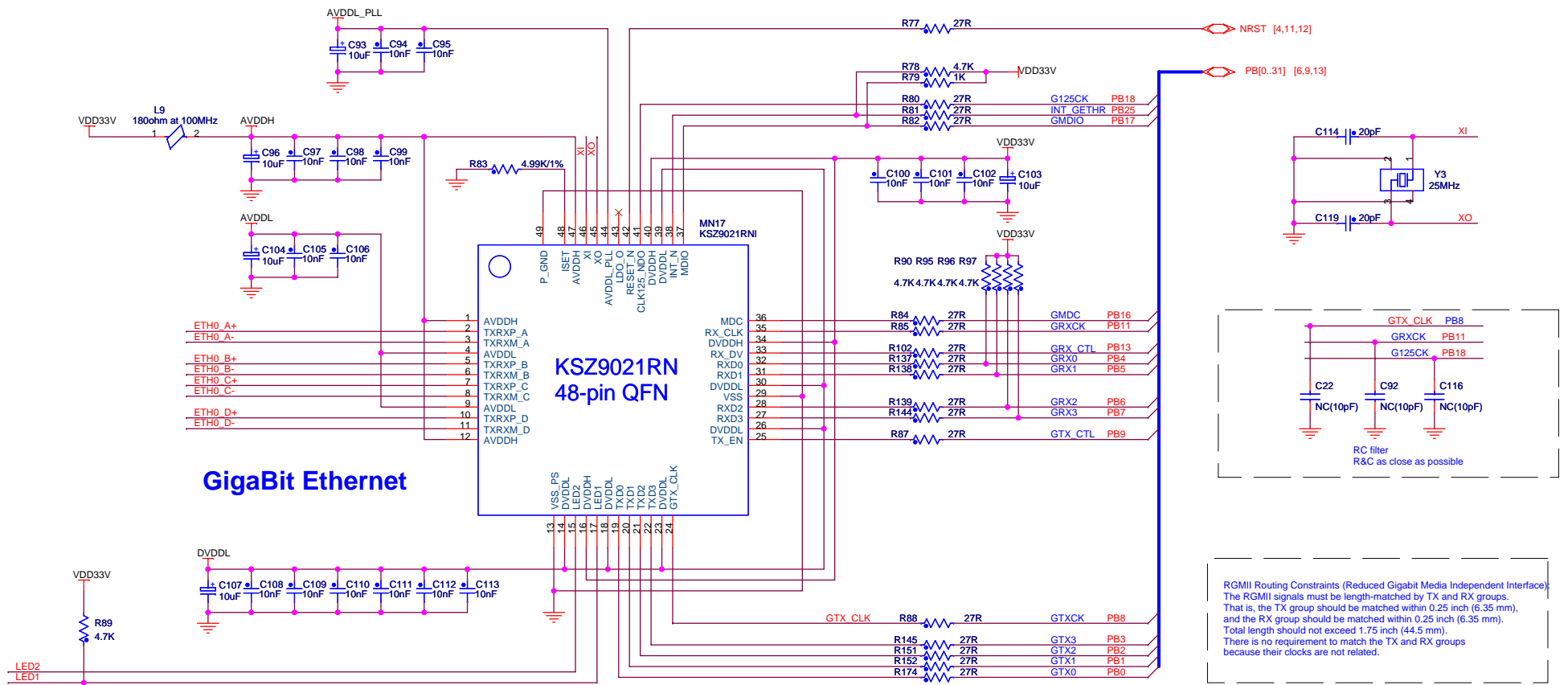

GigaBit Ethernet

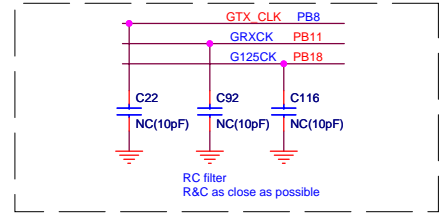

RGMI Routing Constraints (Reduced Gigabit Media Independent Interface):
 The RGMI signals must be length-matched by TX and RX groups. That is, the TX group should be matched within 0.25 inch (6.35 mm), and the RX group should be matched within 0.25 inch (6.35 mm). Total length should not exceed 1.75 inch (44.5 mm). There is no requirement to match the TX and RX groups because their clocks are not related.

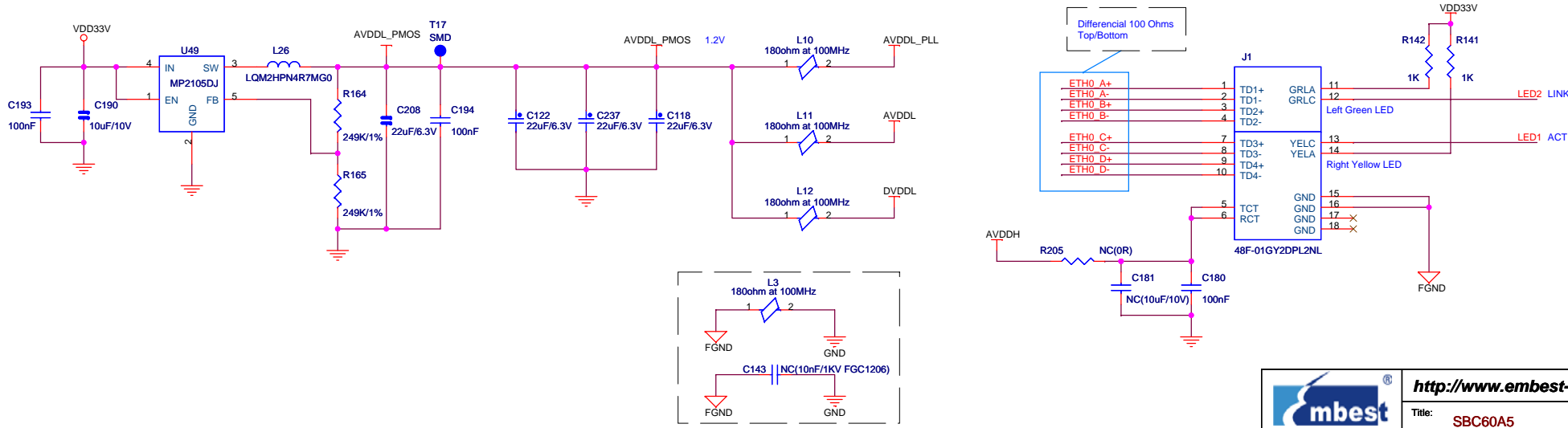

		http://www.embest-tech.com	
		Title: SBC60A5	
Size: A3	Document Number: 08) GigaBit Ethernet	Rev: 130501	
Draw By: ASSP	Date: Friday, June 06, 2014	Sheet: 8 of 13	

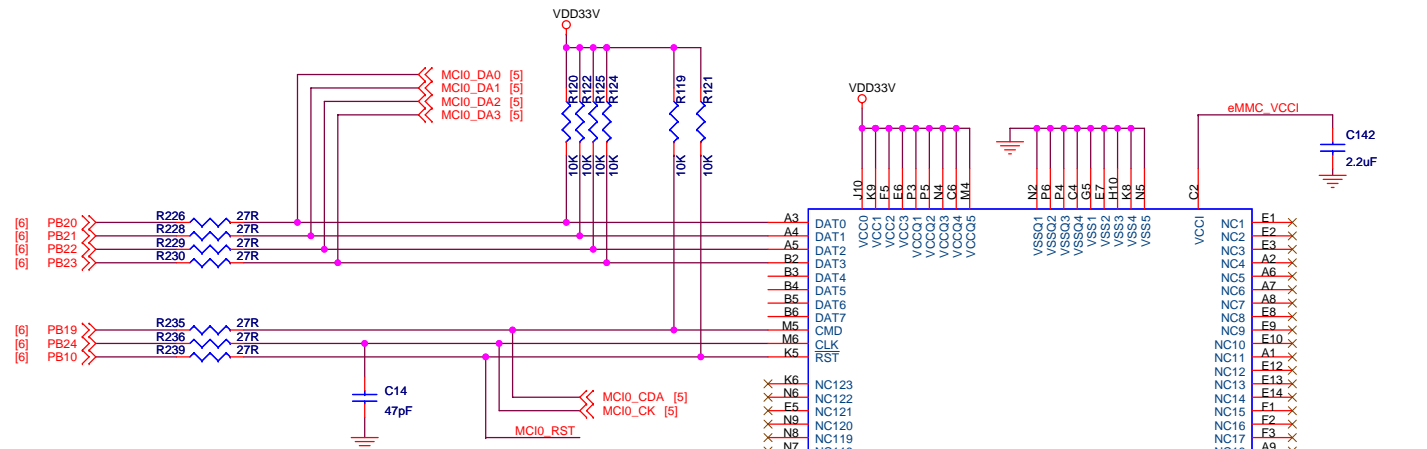

eMMC Flash

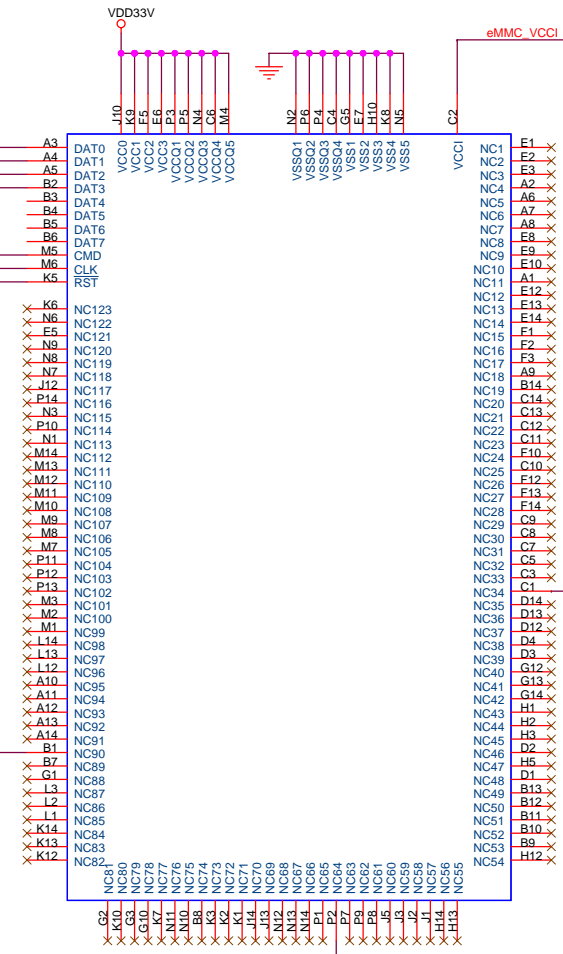
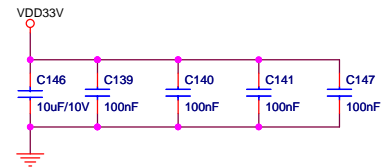

U13
 NC(MTFC2GM/EA-0M IT)
 eMMC 2GB=16Gb
 Operating Temperature Range:
 Blank = 0°C to 70°C
 WT = Standard (-25°C to +85°C)
 IT = Extended (-40°C to +85°C)

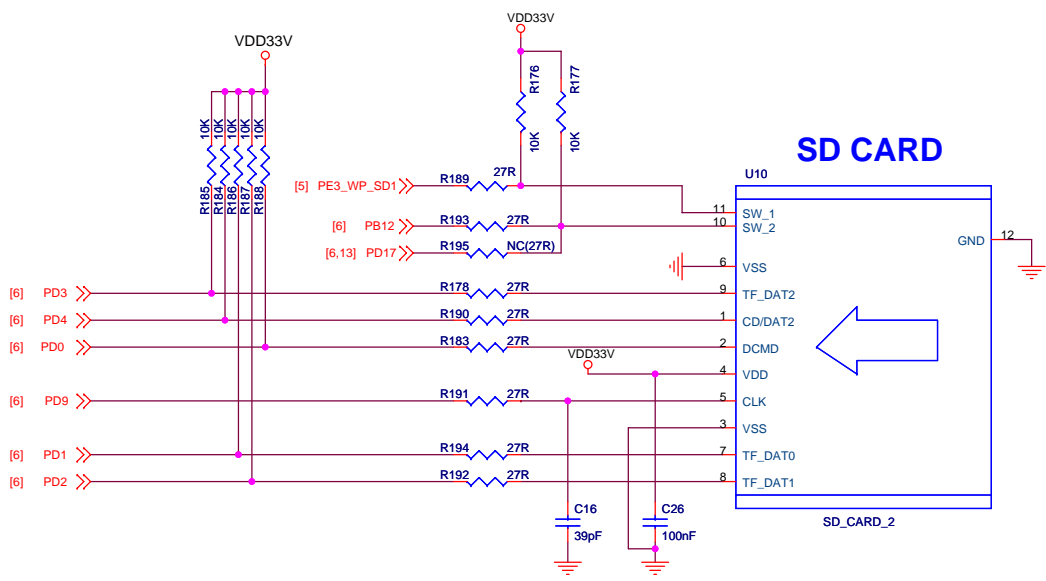

SD CARD

		http://www.embest-tech.com	
		Title: SBC60A5	
Size: A3	Document Number: 09) SD & eMMC	Rev: 130501	
Draw By: ASSP	Date: Friday, June 06, 2014	Sheet: 9 of 13	

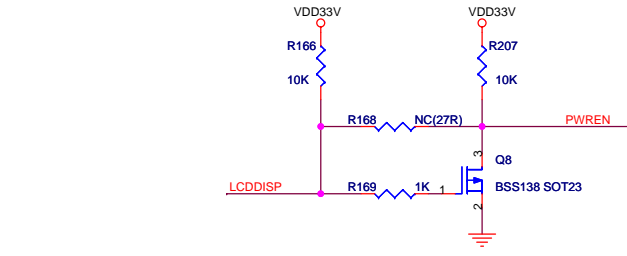
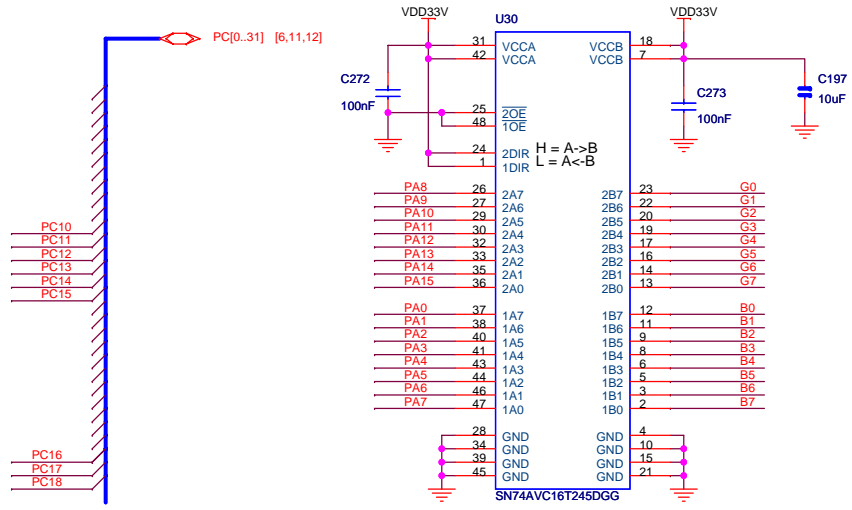
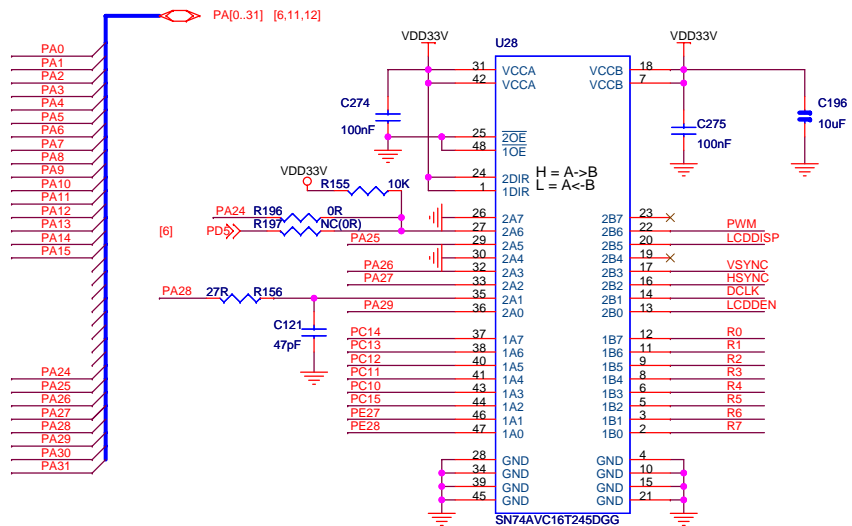

TOUCH

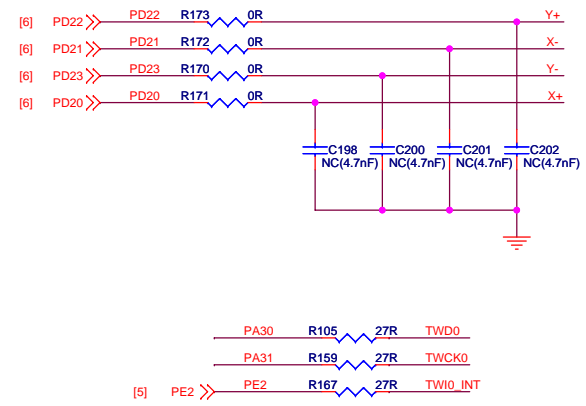

LCD

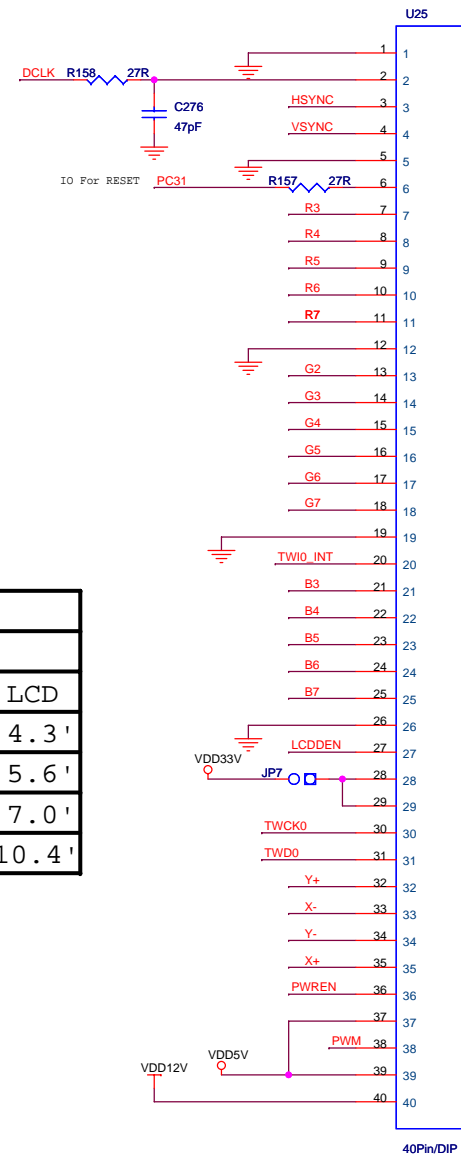

LCD Config

JP OPEN: PE4/5=1
JP CLOSE: PE4/5=0

JP1	JP2	PE4	PE5	LCD
CLOSE	CLOSE	0	0	4.3'
OPEN	CLOSE	1	0	5.6'
CLOSE	OPEN	0	1	7.0'
OPEN	OPEN	1	1	10.4'

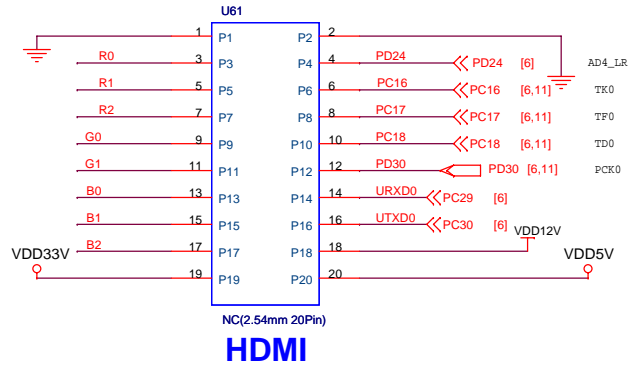

AUDIO OUT

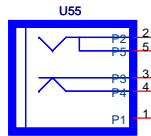

PJ-3064A2-7GZ2S 3.5MM

MIC



mic_in
GND
mic_jack

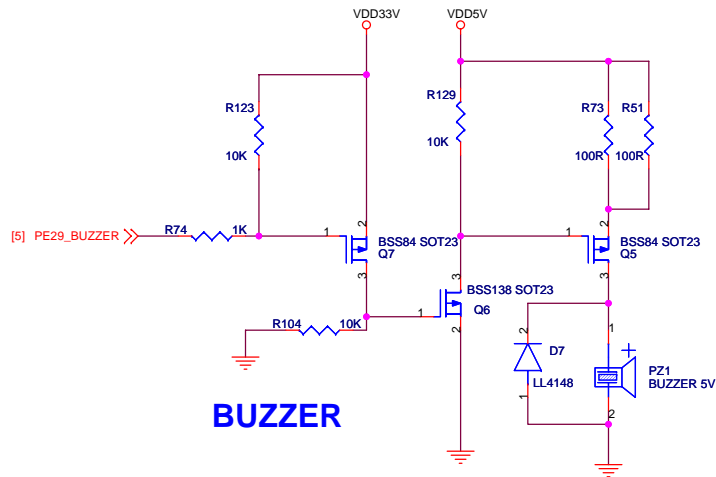

BUZZER

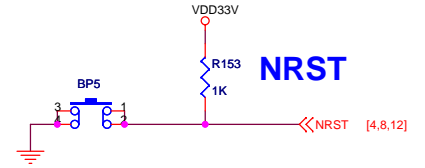
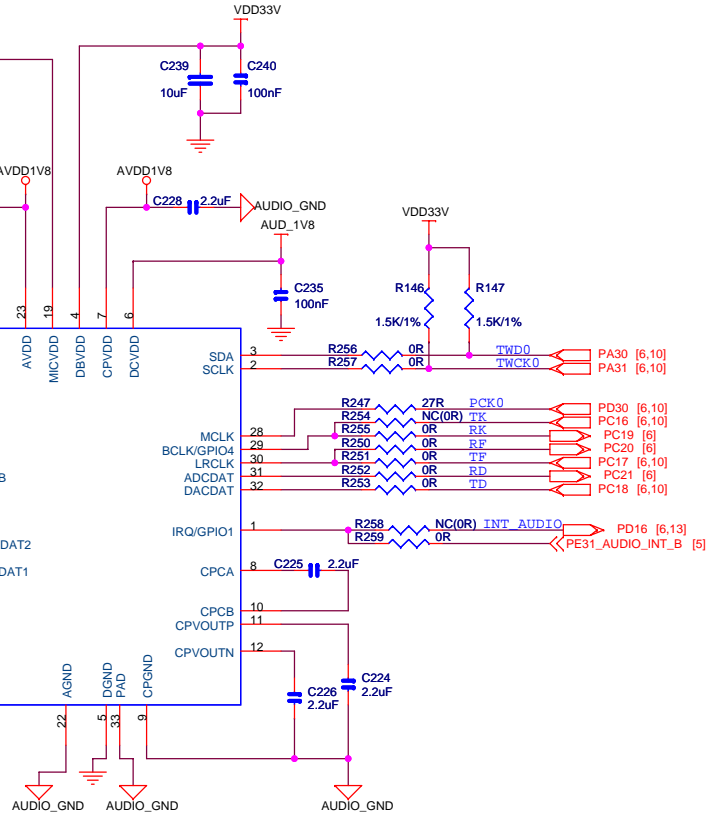

NRST

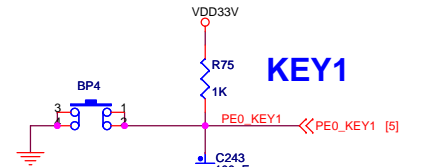

KEY1

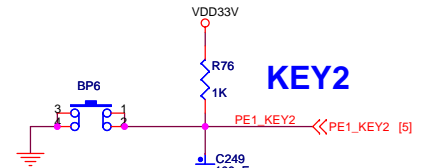

KEY2

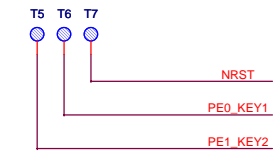

Place T5 T6 T7 to Bottom

EMAC

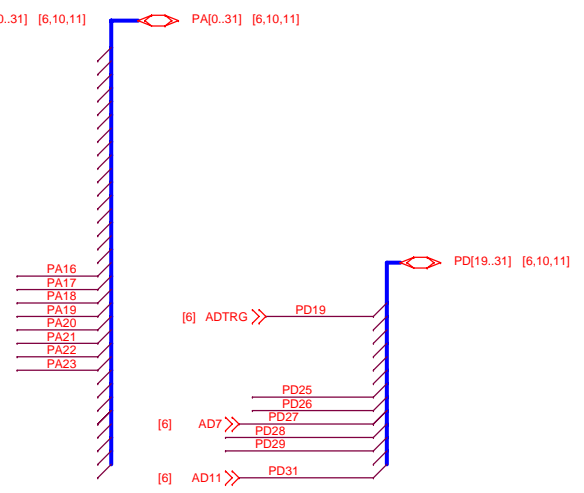
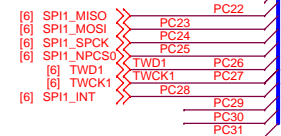
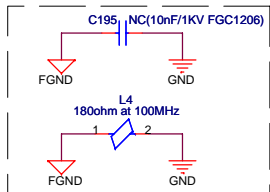
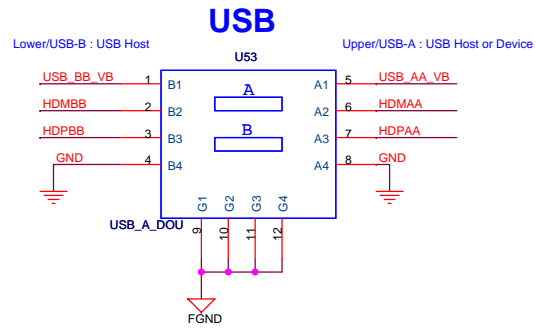
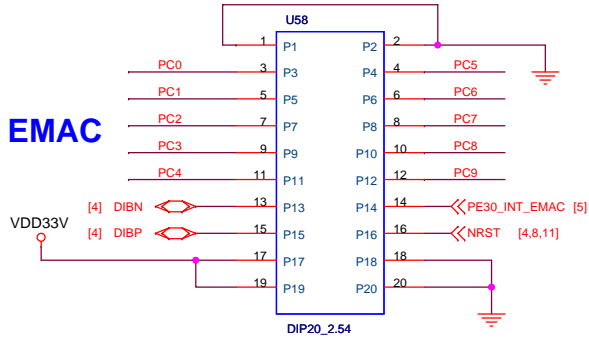

GPIO_16

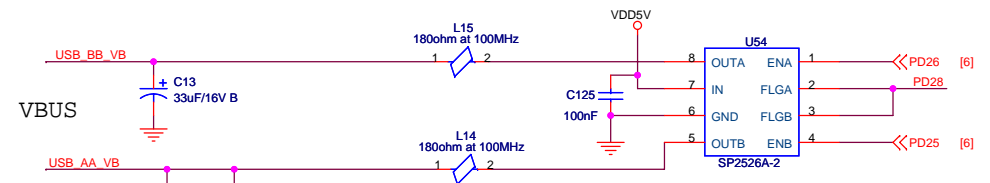
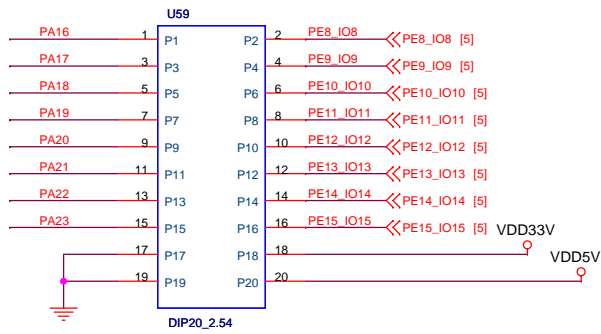

USB POWER

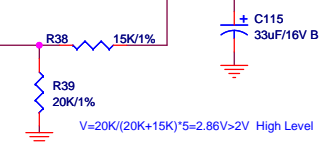

SPI1

ADC

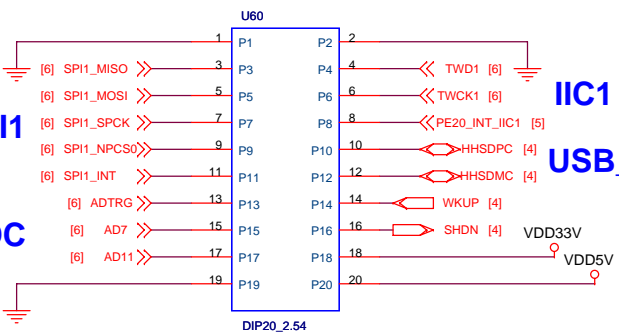

IIC1

USB_C

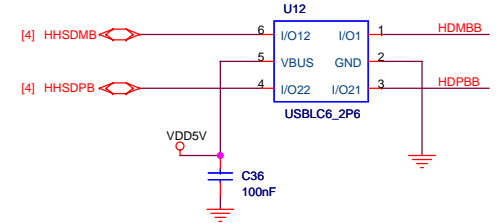
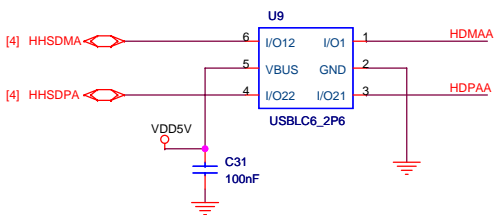

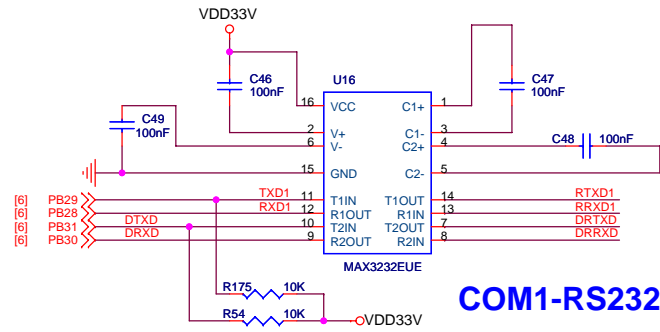

COM1-RS232

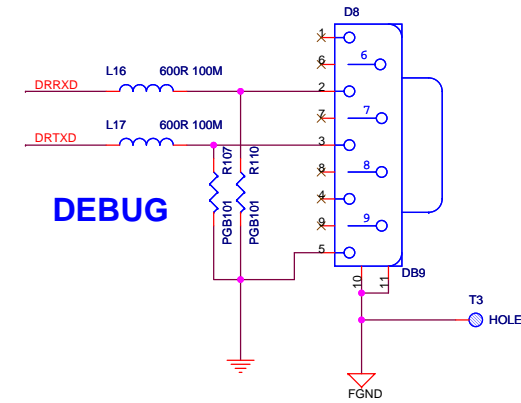
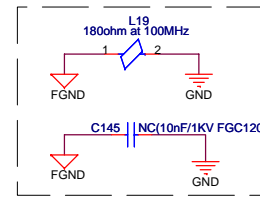

DEBUG

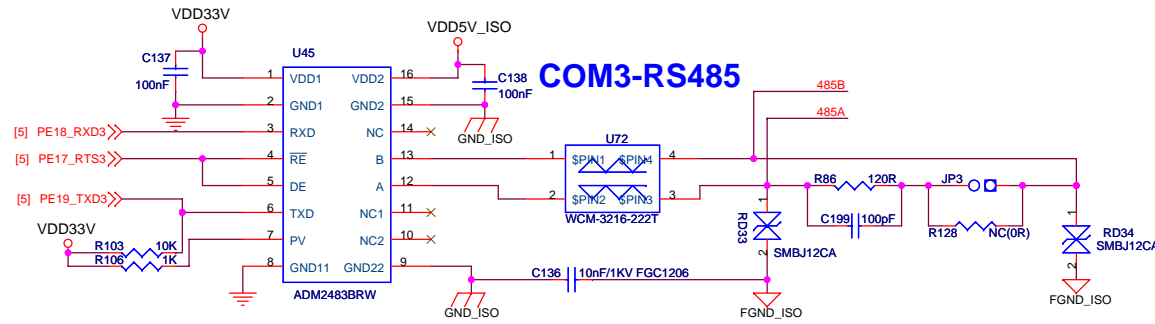

COM3-RS485

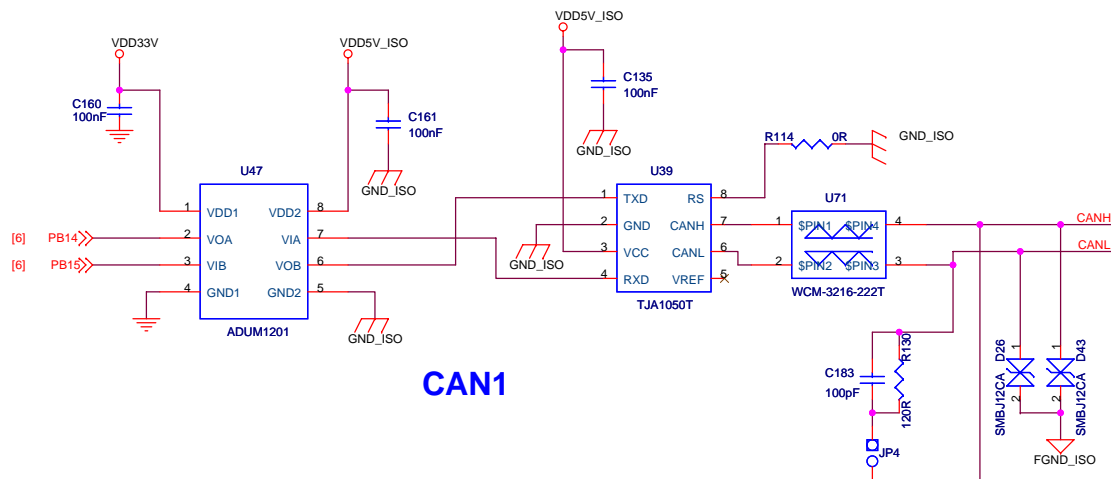
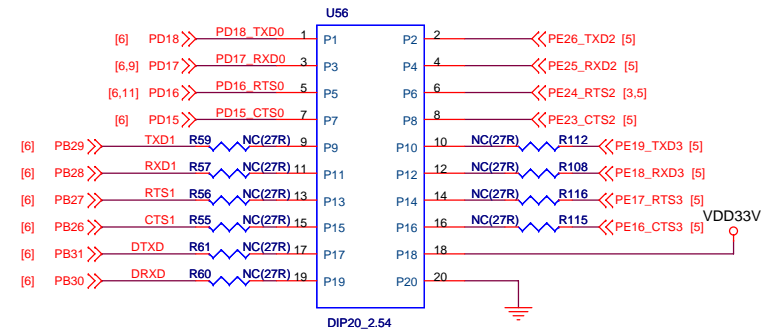

CAN1

