

MarS Board

INDEX

SCHEMATIC	PAGE
01.CONVER PAGE	01
02. SCHEMATIC HISTORY	02
03.BLOCK DIAGRAM	03
04.CPU POWER	04
05 IMX6Q_SOC_A	05
06 IMX6Q_SOC_B	06
07 IMX6Q_SOC_C	07
08 DDR3	08
09 eMMC	09
10 HDMI/TF	10
11 RGMII	11
12 USB/LCD	12
13 DEBUG PORT	13
14 SYSTEM POWER	14
15 EXPANSION PORT	15
16 USB HUB	16
17 LVDS	17

Design	<design>	Embvest Tech Co. LTD		
Review	<review>	Title:MX6		
Authorize	<authorize>	Size	Doc Name	Ver.
Standardize	<standardize>	A3	01.CONVER PAGE	X1
		Date	Friday, March 08, 2013	Sheet 1 of 17

Schematic History

2012-12-14

1.Add R306 for 3P3V_DEBUG bleeding

2013-01-28

1.Add LVDS Port

Design	<design>	Embest Tech Co. LTD		
Review	<review>	Title:MX6		
Authorize	<authorize>	Size	Doc Name	Ver.
Standardize	<standardize>	A3	02.Schematic History	X1
		Date	Friday, March 08, 2013	Sheet 2 of 17

MarS Board Block

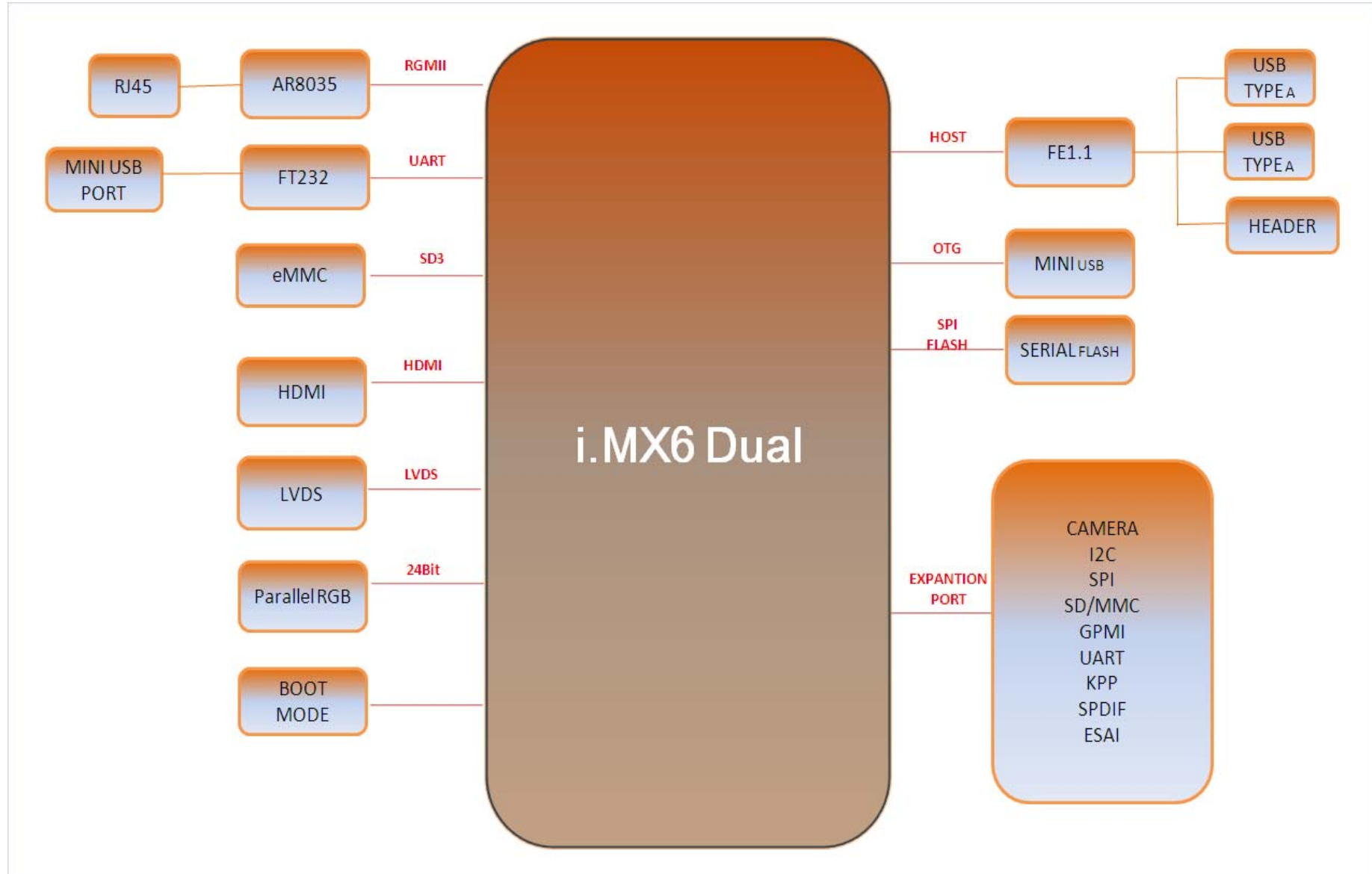

Design	<design>	Embest Info & Tech Co. LTD		
Review	<review>	Title iMX6		
Authorize	<authorize>	Size	Doc Name	Ver.
Standardize	<standardize>	A3	03.SYSTEM BLOCK	X1
		Date	Friday, March 15, 2013	Sheet 3 of 17

U1E
MCIMX6DSFYM10AC

i.MX6D - POWER

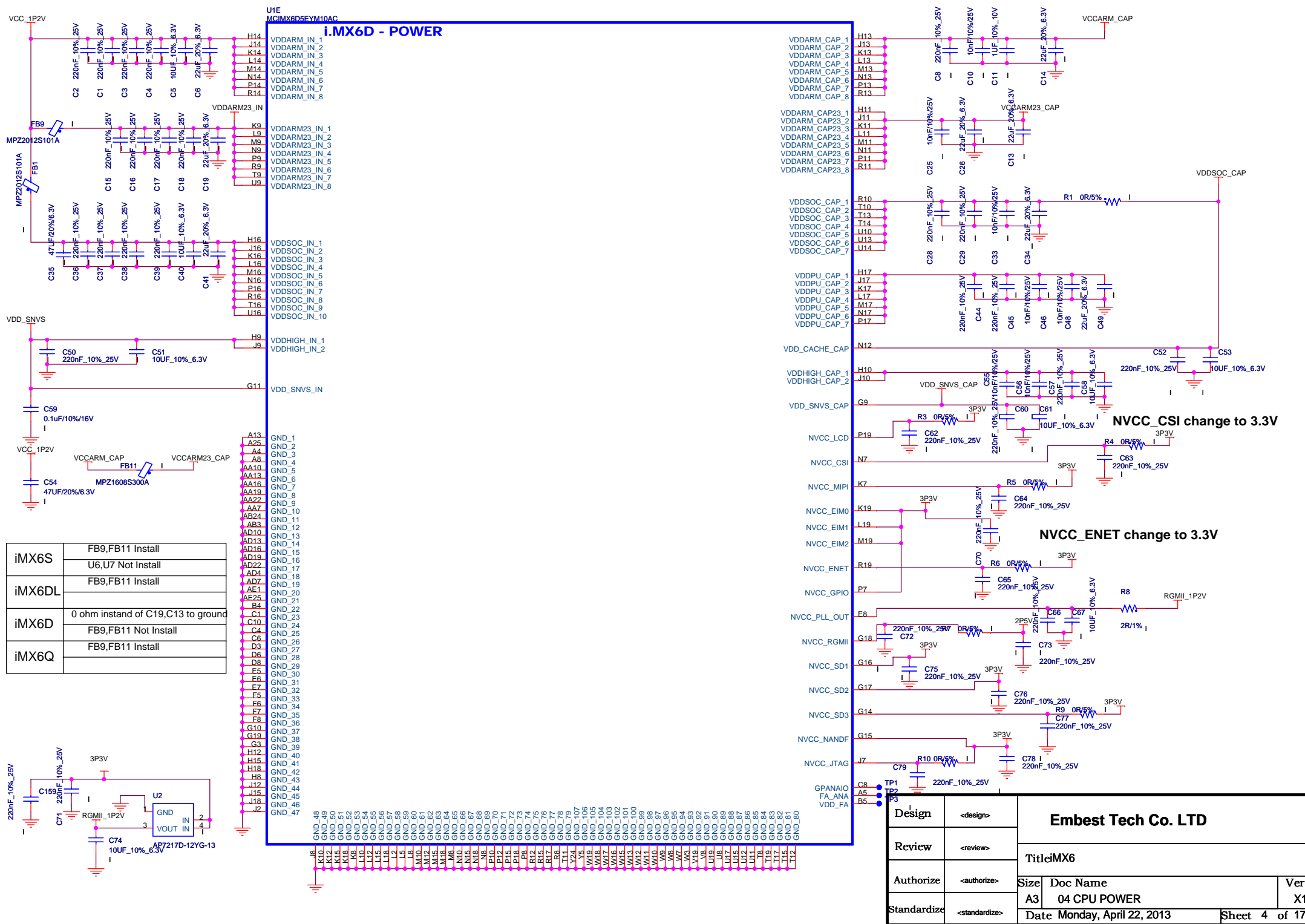

iMX6S	FB9,FB11 Install U6,U7 Not Install
iMX6DL	FB9,FB11 Install
iMX6D	0 ohm instand of C19,C13 to ground FB9,FB11 Not Install
iMX6Q	FB9,FB11 Install

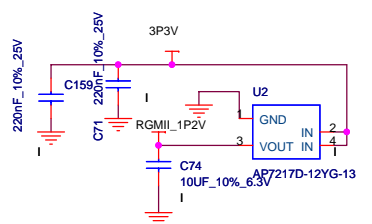

Design	<design>	Embest Tech Co. LTD			
Review	<review>				
Authorize	<authorize>	Title	iMX6		
Standardize	<standardize>	Size	A3	Ver.	X1
		Doc Name	04 CPU POWER		
		Date	Monday, April 22, 2013	Sheet	4 of 17

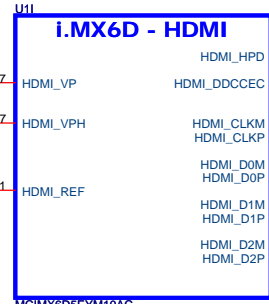
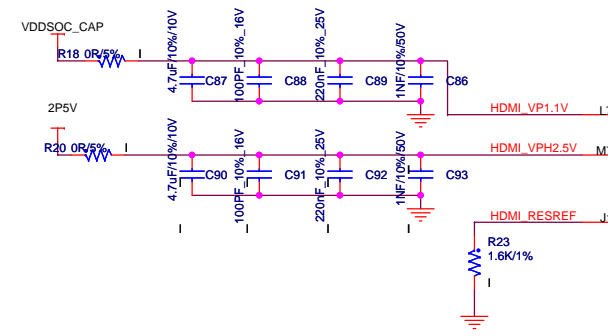
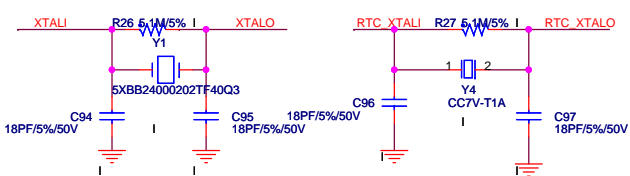
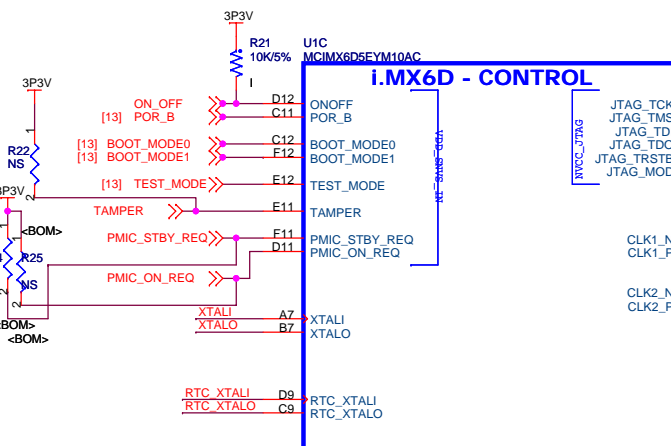
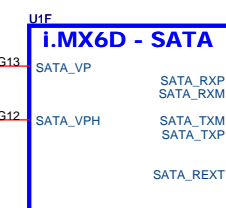
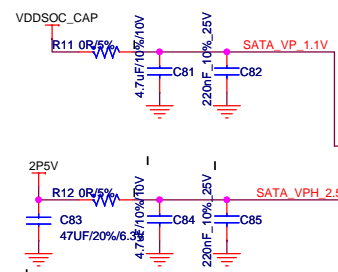
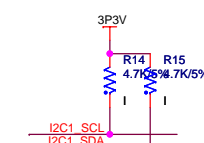
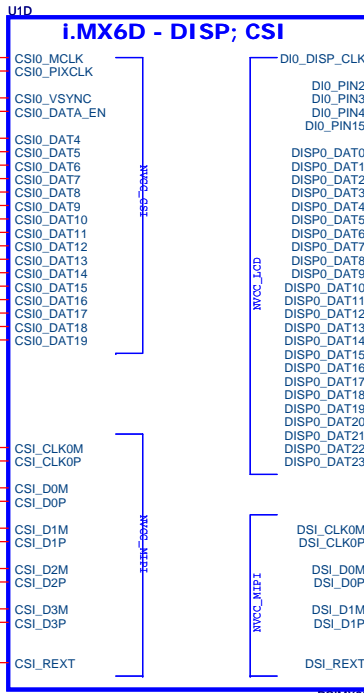
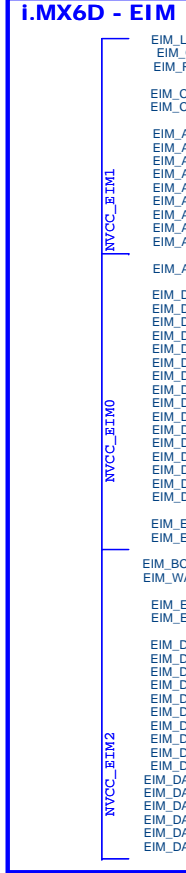

Design	<design>	Embest Tech Co. LTD		
Review	<review>			
Authorize	<authorize>	TitleIMX6		
Standardize	<standardize>	Size	Doc Name	Ver.
		A3	05 IMX6Q_SOC_A	X1
		Date	Tuesday, May 07, 2013	Sheet 5 of 17

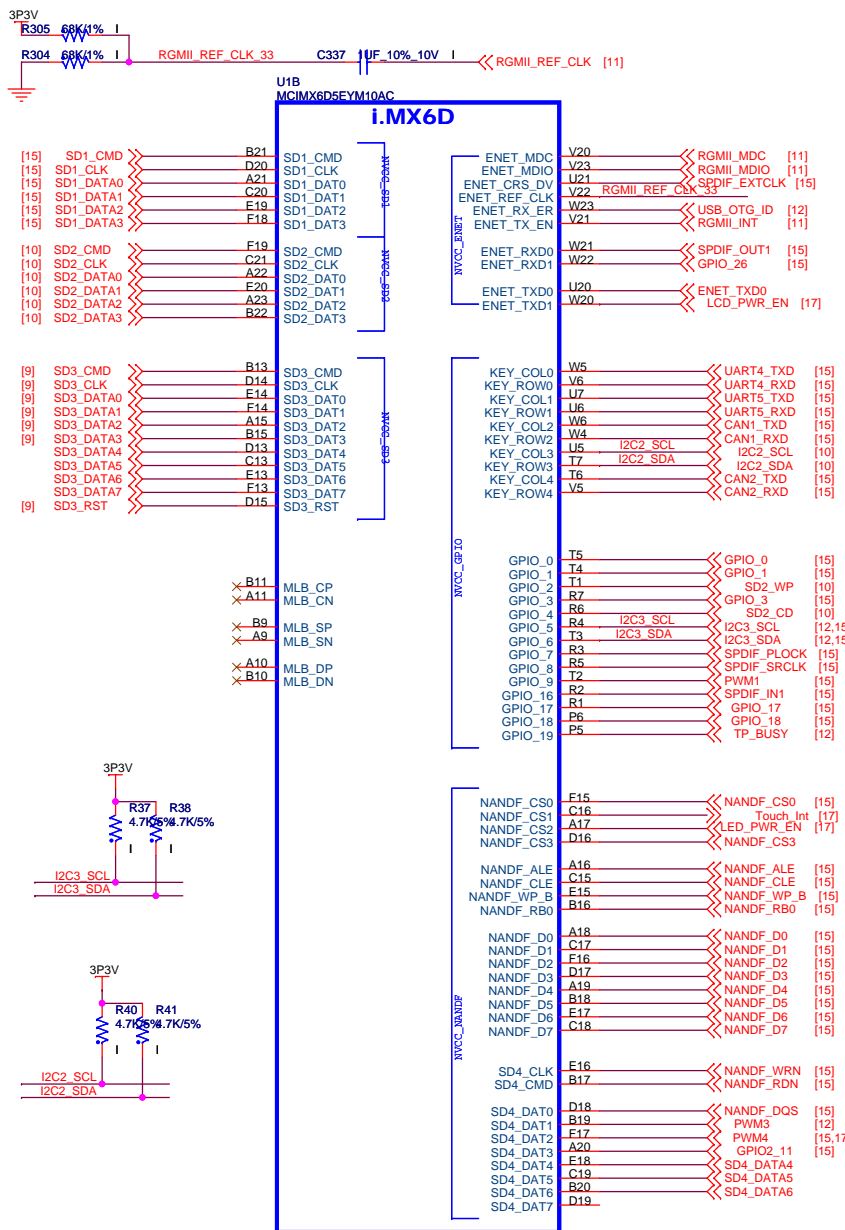

Layout: High speed data lines : 50 ohms
Put the 33ohm resistors in this page near imx6Q

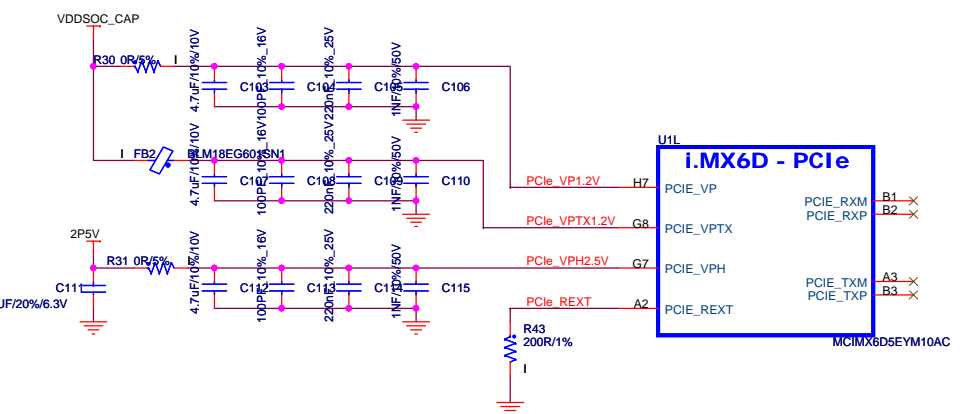
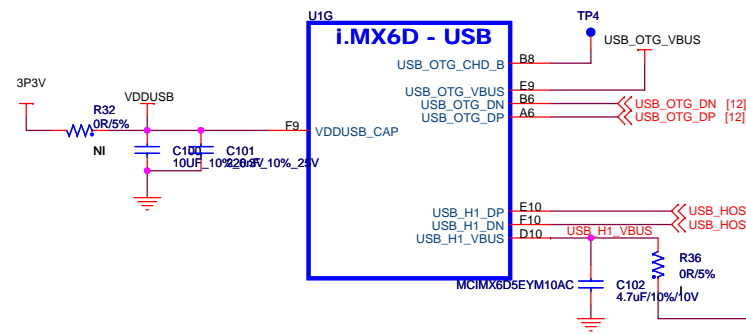
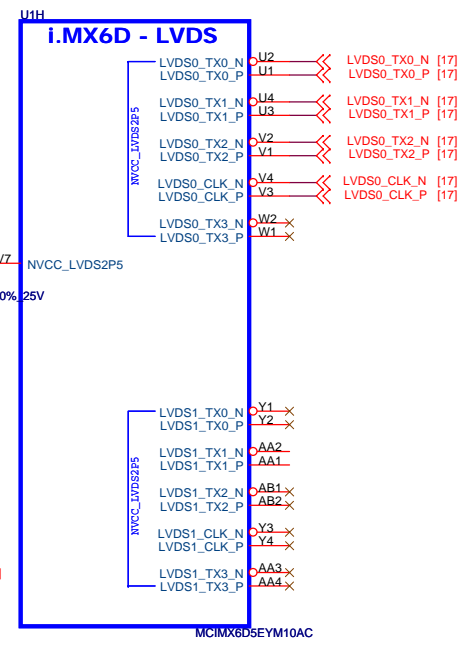
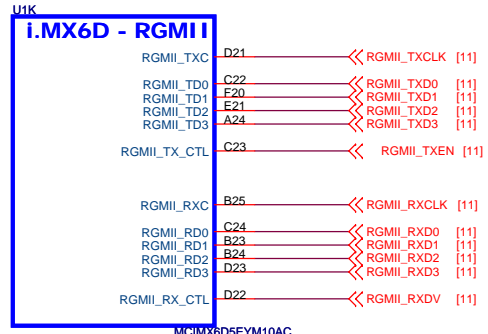

Design	<design>	Embest Tech Co. LTD		
Review	<review>			
Authorize	<authorize>	TitleIMX6		
Standardize	<standardize>	Size	Doc Name	Ver.
		A3	06 IMX6Q_SOC_B	X1
		Date	Tuesday, May 07, 2013	Sheet 6 of 17

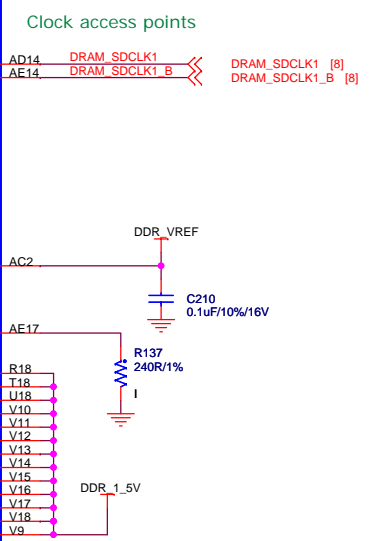
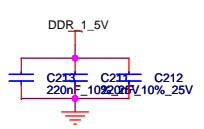
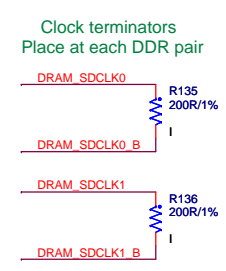
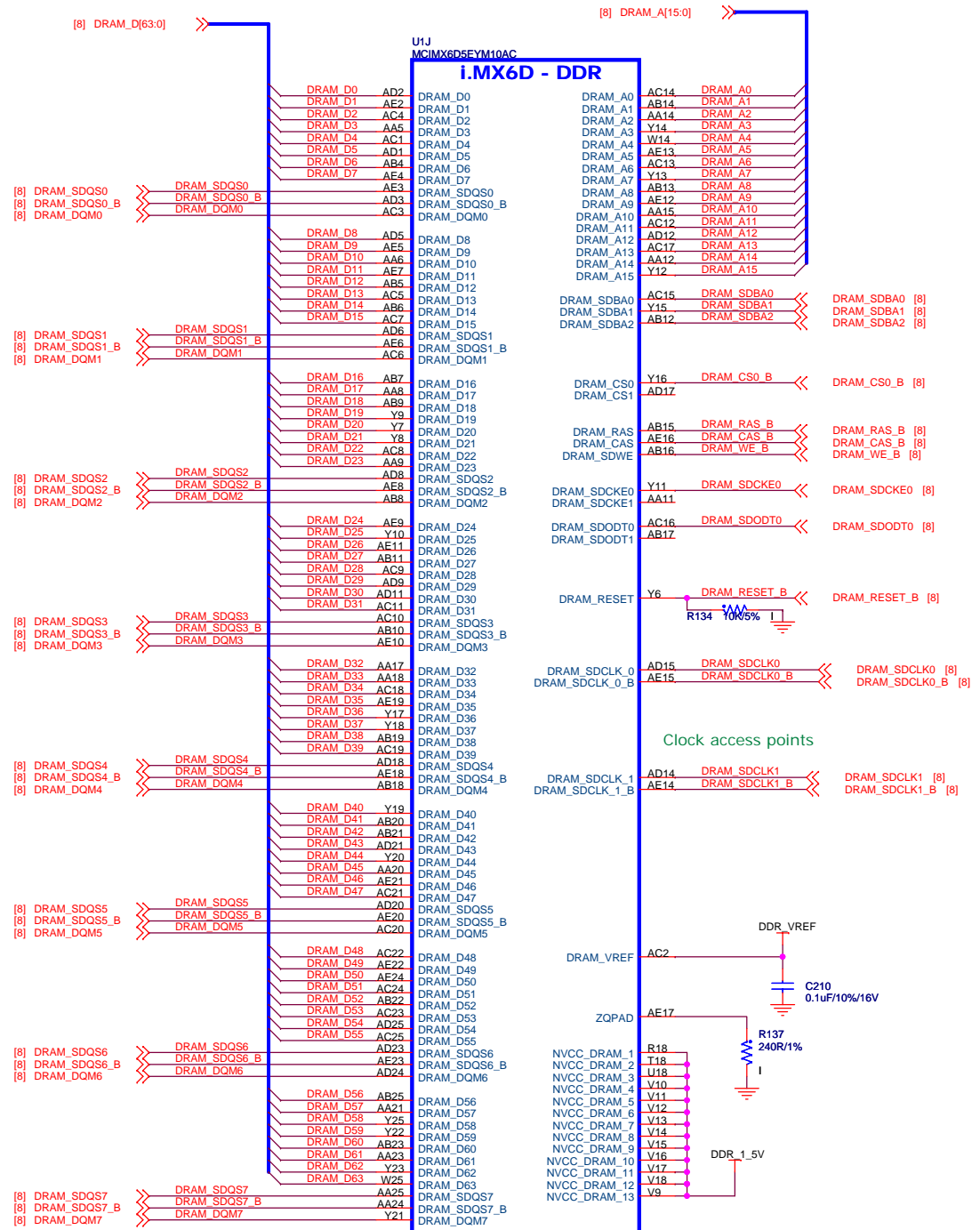

Design	<design>	Embest Tech Co. LTD		
Review	<review>			
Authorize	<authorize>	Title iMX6		
Standardize	<standardize>	Size	Doc Name	Ver.
		A3	07 IMX6Q_SOC_C	X1
		Date	Tuesday, May 07, 2013	Sheet 7 of 17

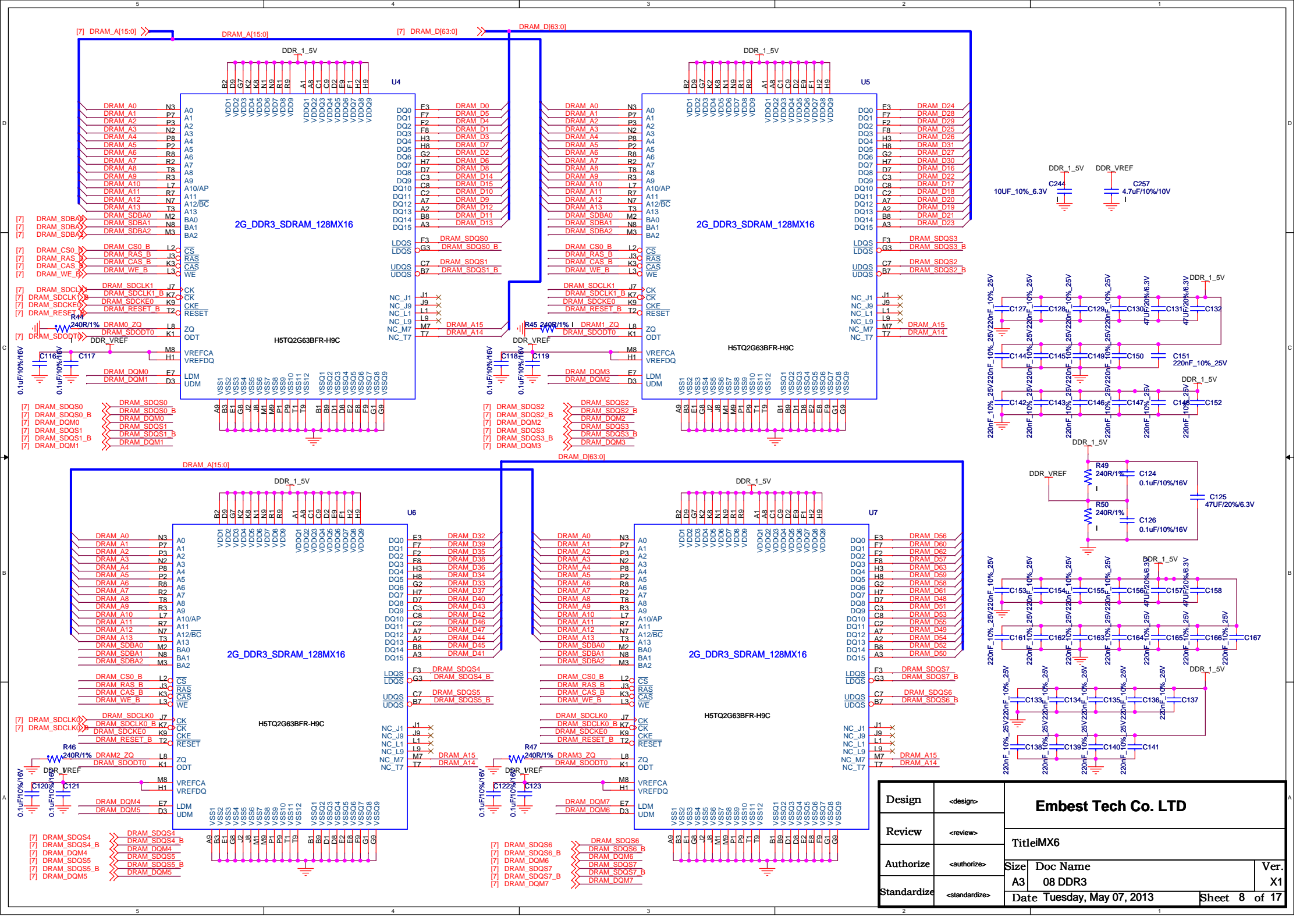

Design	<design>	Embest Tech Co. LTD		
Review	<review>			
Authorize	<authorize>	Size	Doc Name	Ver.
Standardize	<standardize>	A3	08 DDR3	X1
		Date	Tuesday, May 07, 2013	Sheet 8 of 17

eMMC

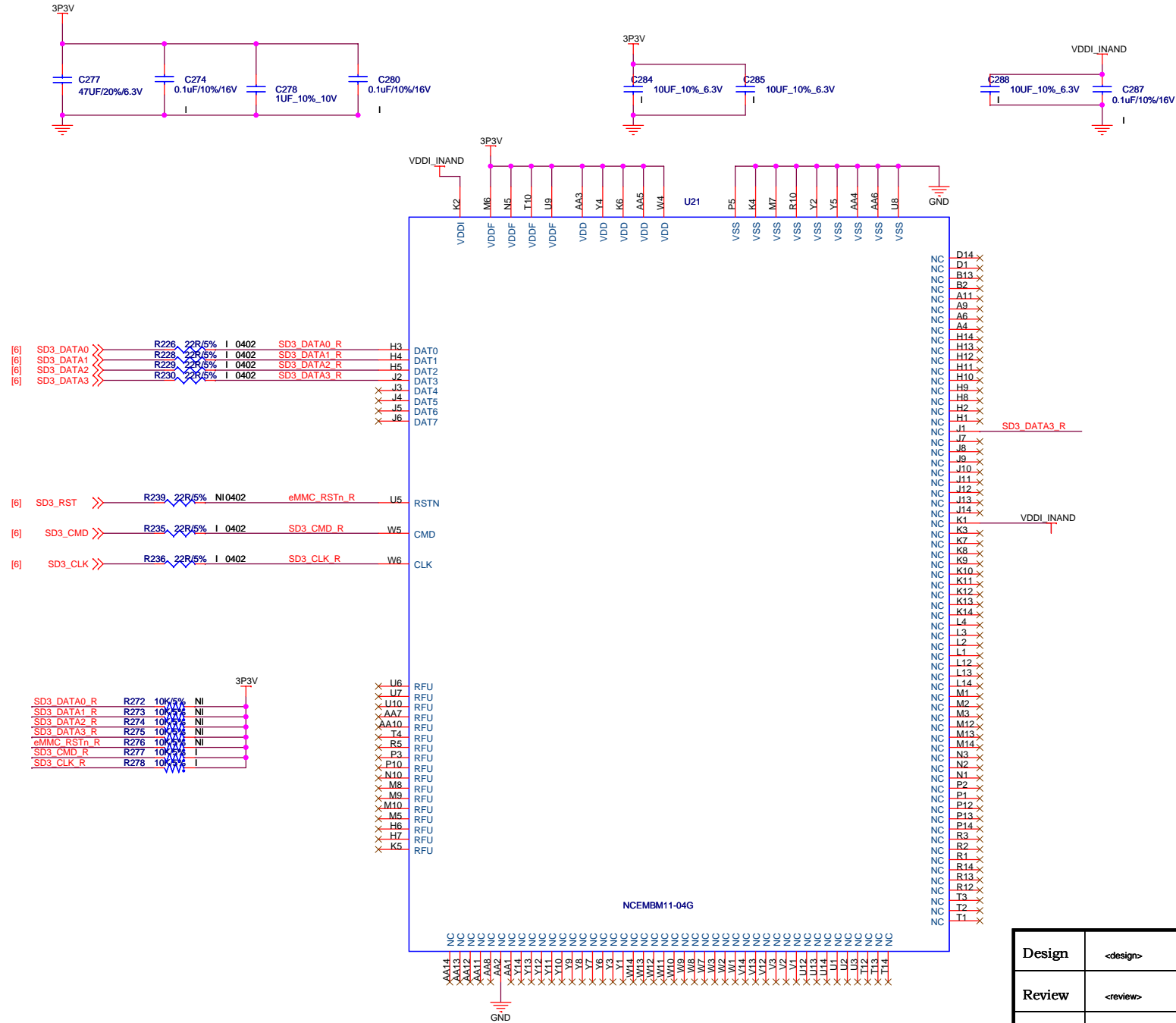

Design	<design>	Embest Tech Co. LTD		
Review	<review>			
Authorize	<authorize>	Size	Doc Name	Ver.
Standardize	<standardize>	A3	09 eMMC	X1
		Date Tuesday, May 07, 2013		Sheet 9 of 17

HDMI

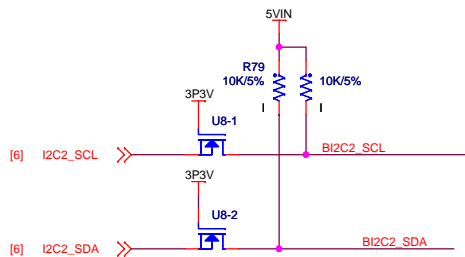

Layout: HDMI 100 ohm differential pairs

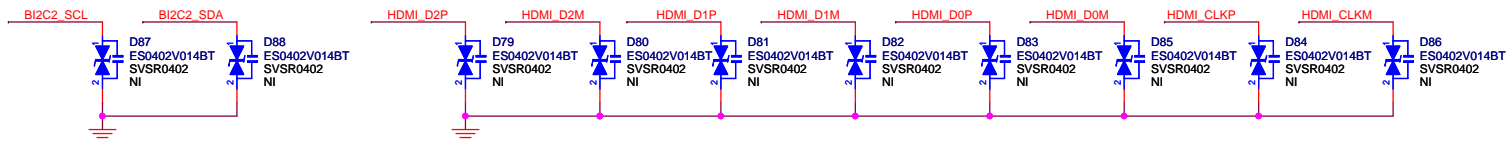
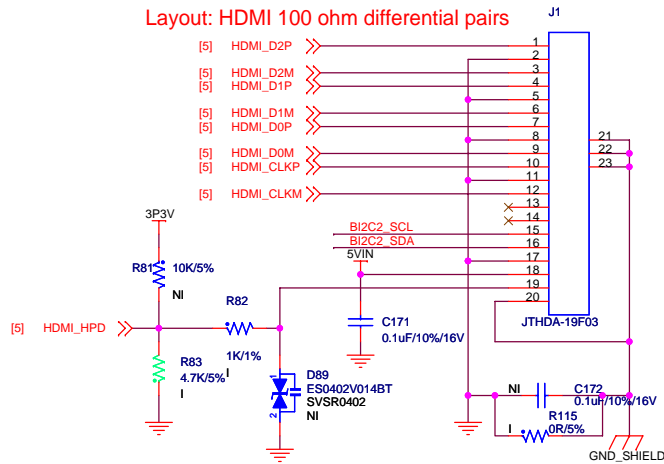

TF CARD

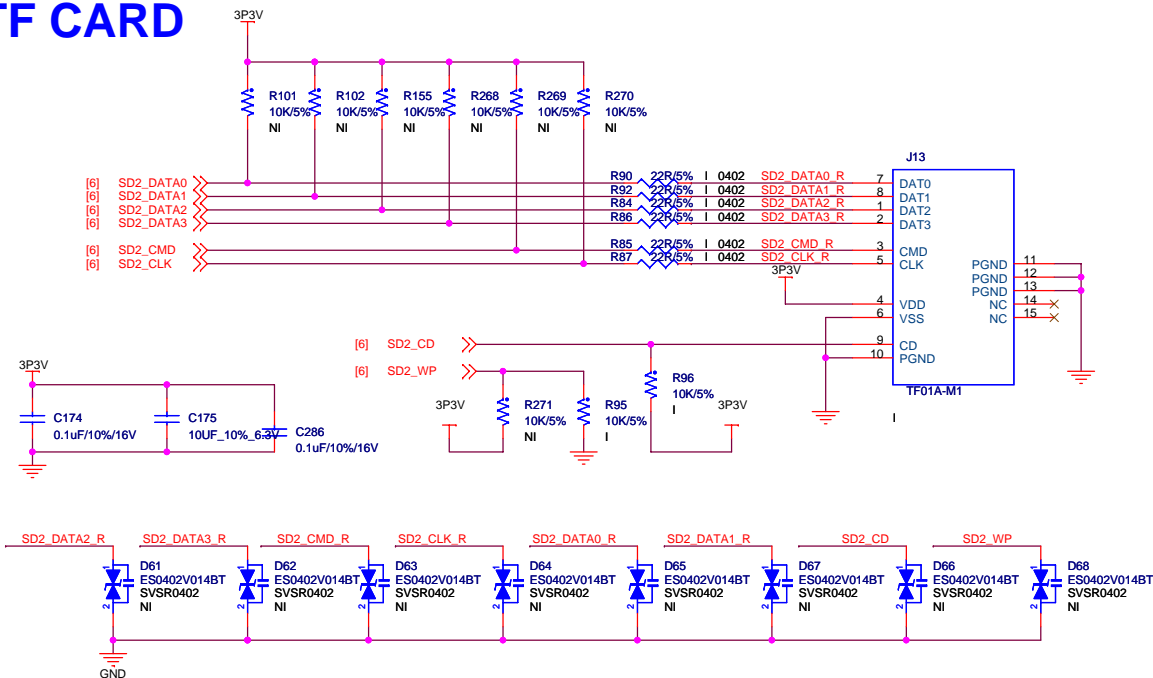

SPI FLASH

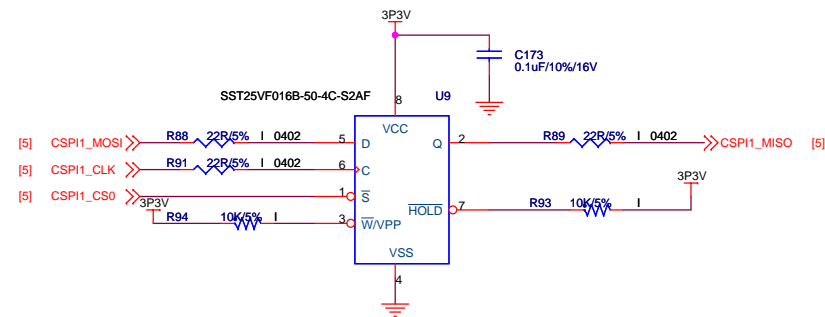

Design	<design>	Embest Tech Co. LTD			
Review	<review>				
Authorize	<authorize>	Title:MX6			
Standardize	<standardize>	Size	Doc Name	Ver.	
		A3	10 HDMI/TF	X1	
		Date	Tuesday, May 07, 2013	Sheet	10 of 17

LAN

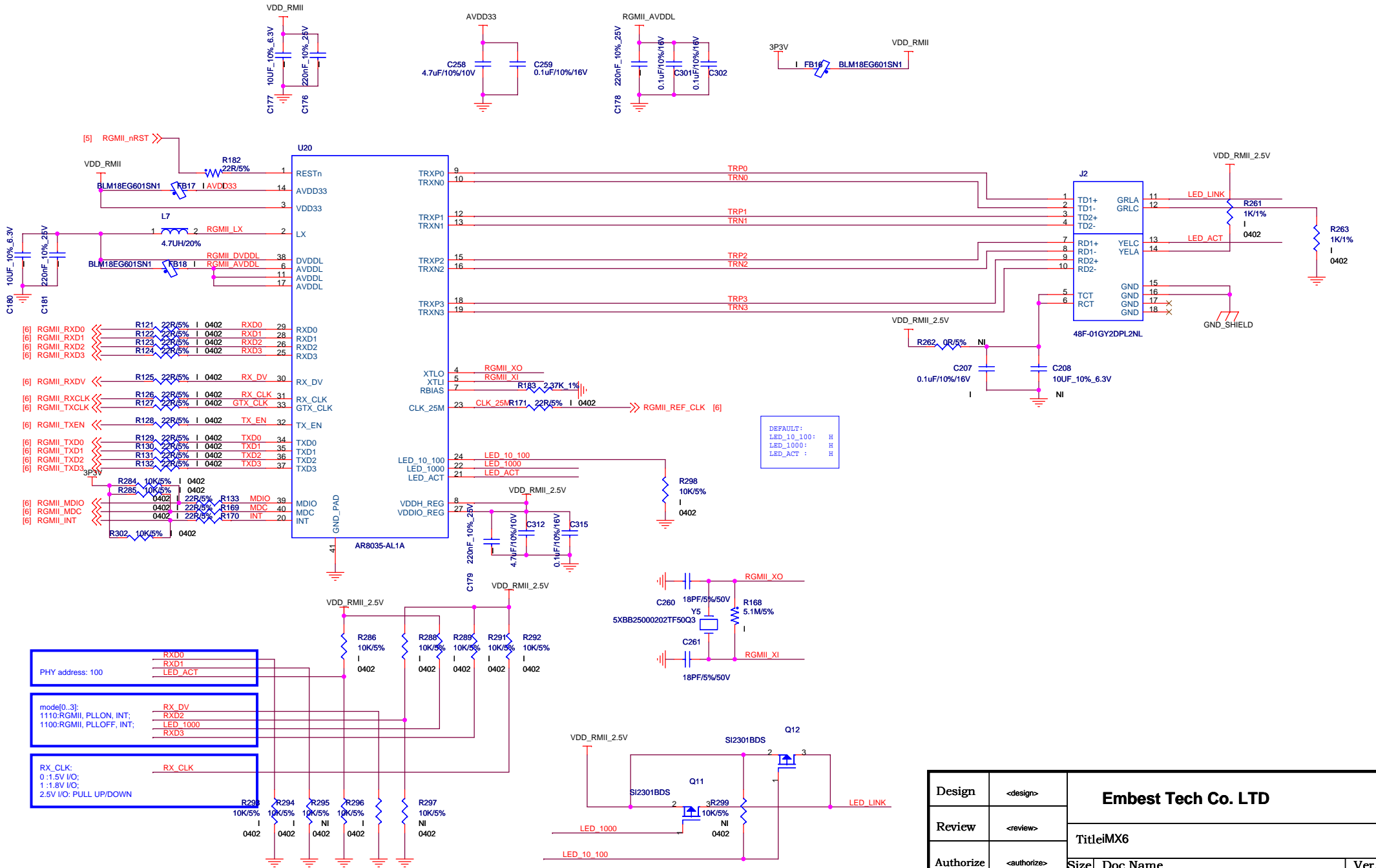

Design	<design>	Embest Tech Co. LTD		
Review	<review>			
Authorize	<authorize>	Title:MX6		Ver.
Standardize	<standardize>	Size	Doc Name	X1
		Date	Tuesday, May 07, 2013	Sheet 11 of 17

USB OTG

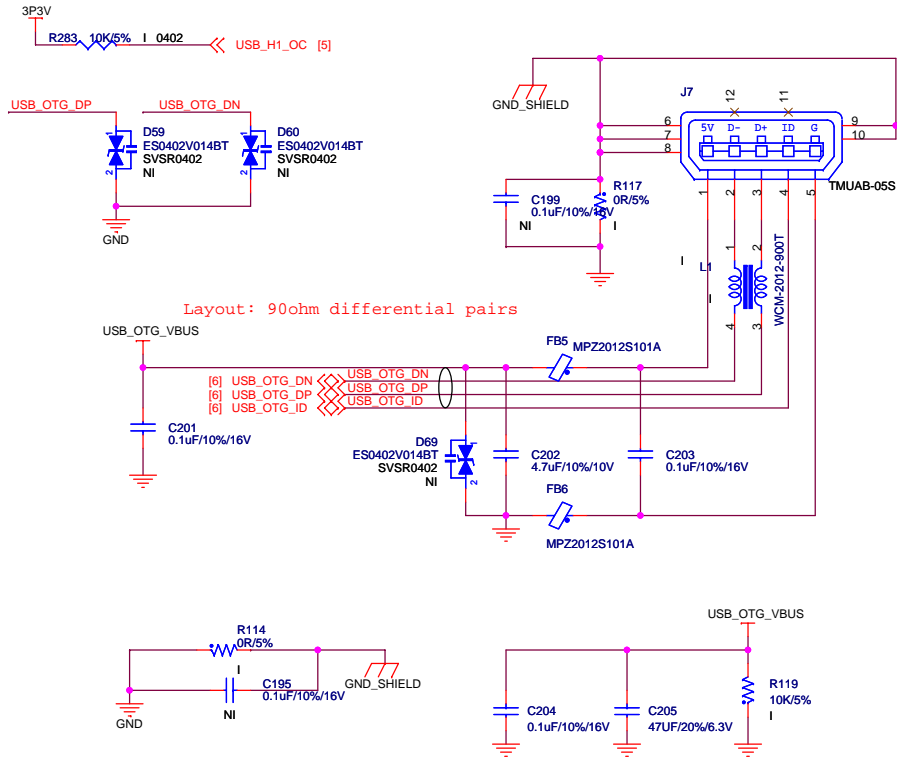

Note: Power_EN active Low

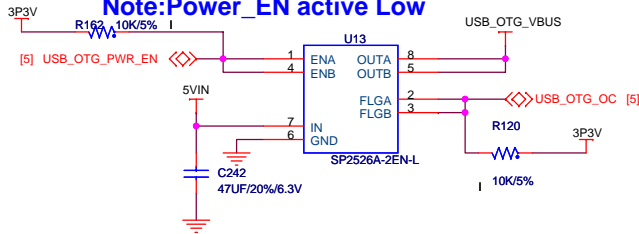

LCD PORT

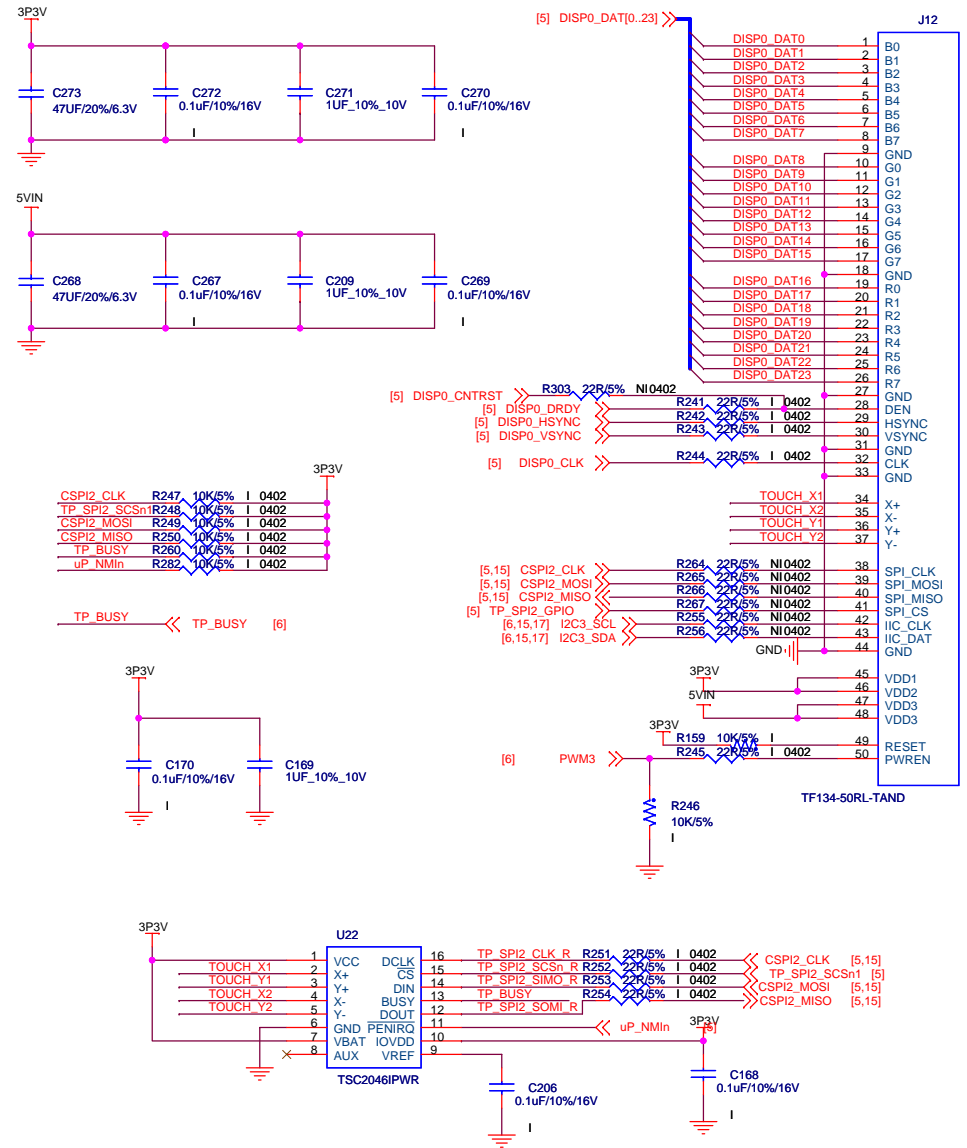

Design	<design>	Embest Tech Co. LTD		
Review	<review>			
Authorize	<authorize>	Title: MX6		
Standardize	<standardize>	Size	Doc Name	Ver.
		A3	12 USB/LCD	X1
		Date	Tuesday, May 07, 2013	Sheet 12 of 17

DEBUG PORT

RESERVE

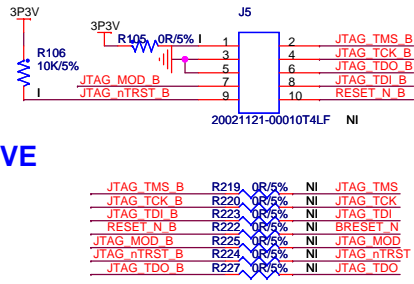

JTAG

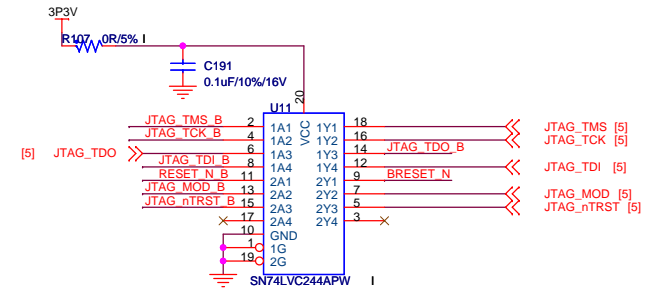
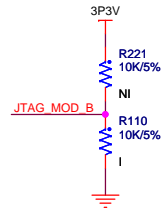

HW MONITOEER

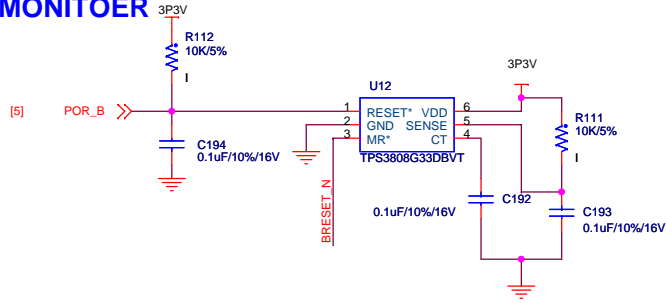

RESET KEY

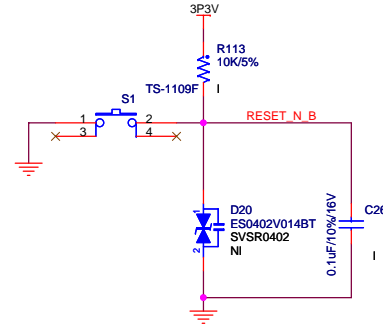

BOOT MODE

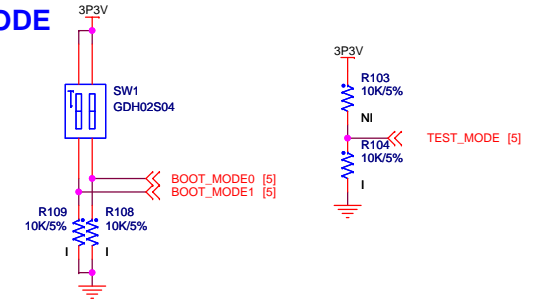

DEBUG COM

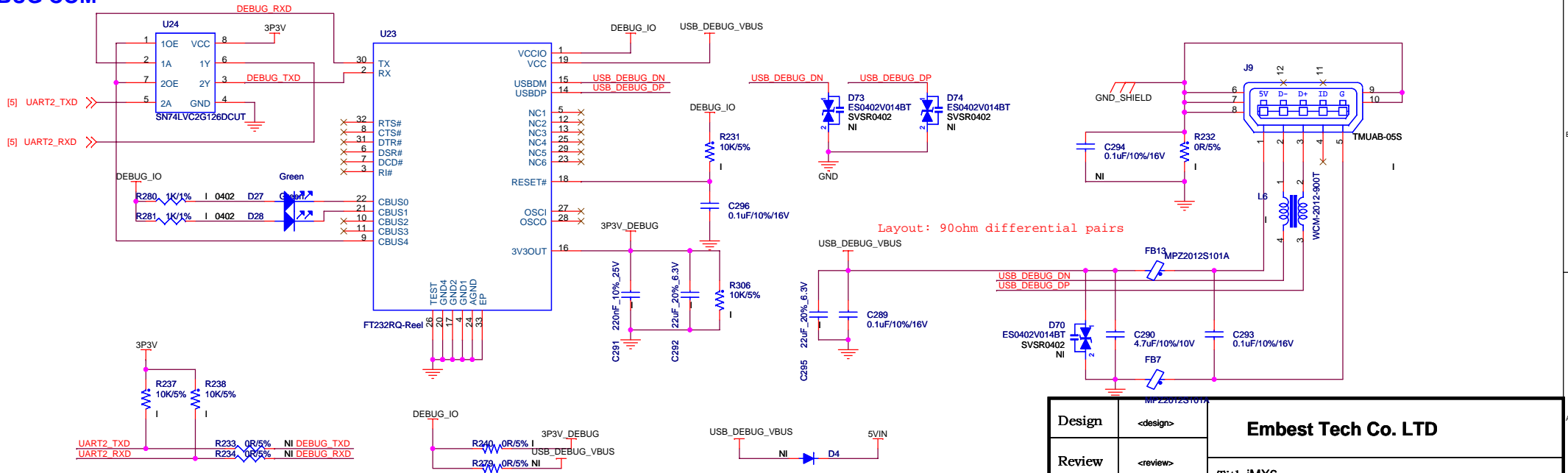

Design	<design>	Embest Tech Co. LTD			
Review	<review>				
Authorize	<authorize>	TitleIMX6	Size	Doc Name	Ver.
Standardize	<standardize>	A3	13 DEBUG PORT		X1
		Date	Tuesday, May 07, 2013	Sheet 13 of 17	

SYSTEM POWER

DDR POWER

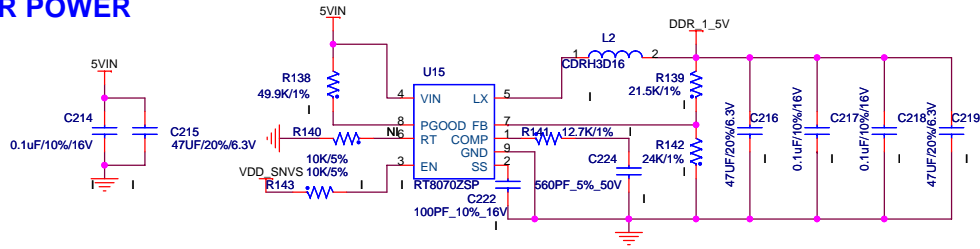

VCORE

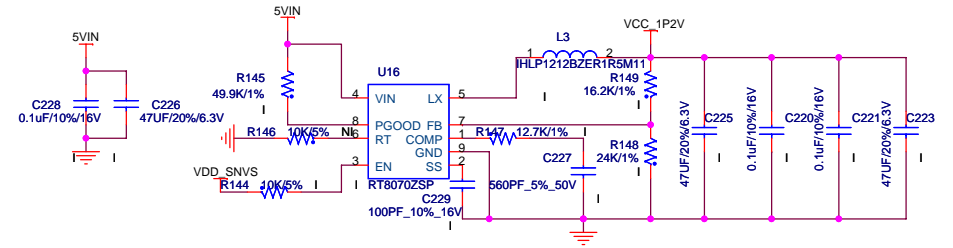

VDD_SNVS

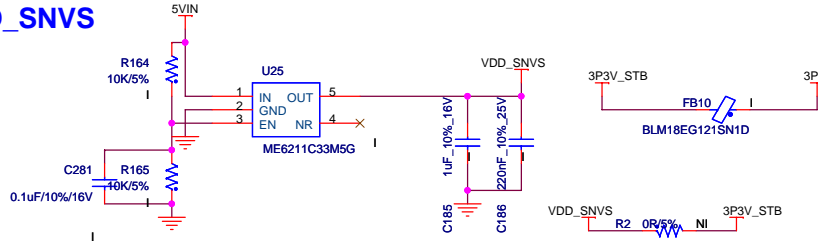

+3P3V SWITCH

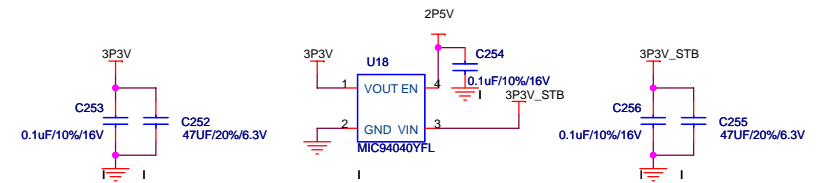

+3P3V

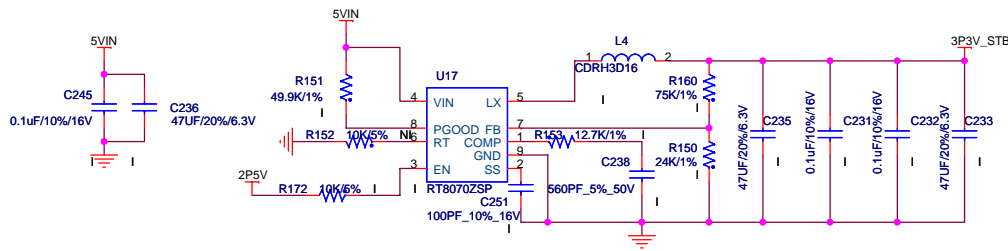

+5V DC_IN

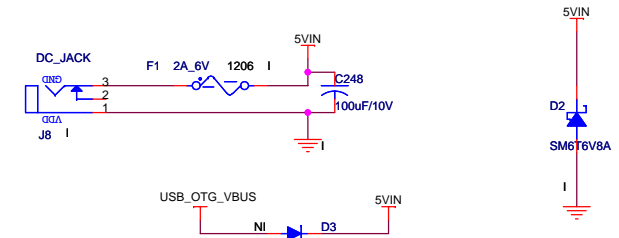

+2P5V

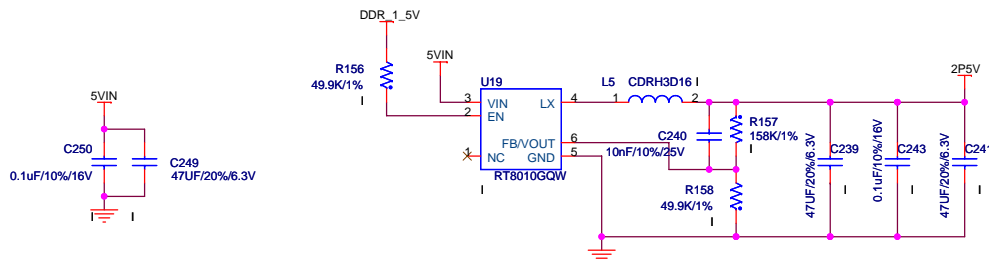

Design	<design>	Embest Tech Co. LTD		
Review	<review>			
Authorize	<authorize>	Title:MX6		
Standardize	<standardize>	Size	Doc Name	Ver.
		A3	14 SYSTEM POWER	X1
		Date	Monday, April 22, 2013	Sheet 14 of 17

EXPANTION PORT

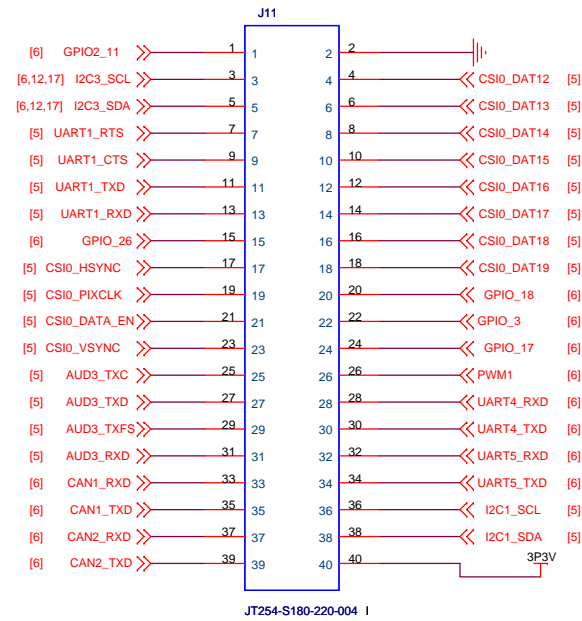
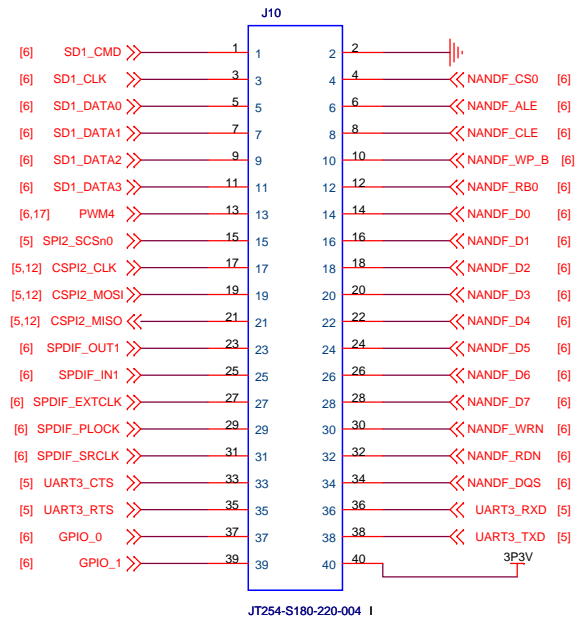

USER LED

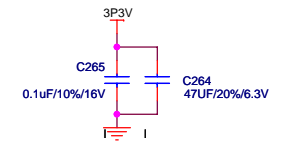
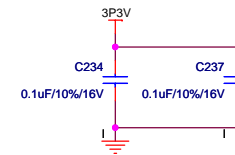
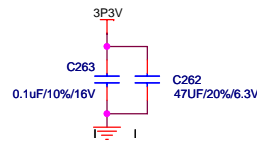
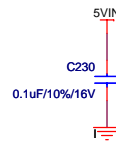
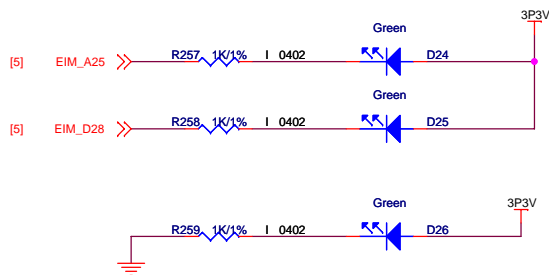

Design	<design>	Embest Tech Co. LTD		
Review	<review>			
Authorize	<authorize>	Title:MX6		
Standardize	<standardize>	Size	Doc Name	Ver.
		A3	15 EXPANSION PORT	X1
		Date	Tuesday, May 07, 2013	Sheet 15 of 17

USB HUB

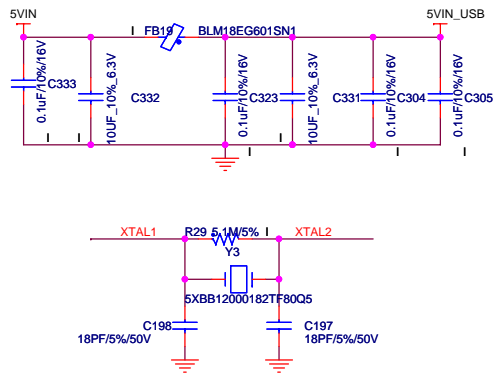
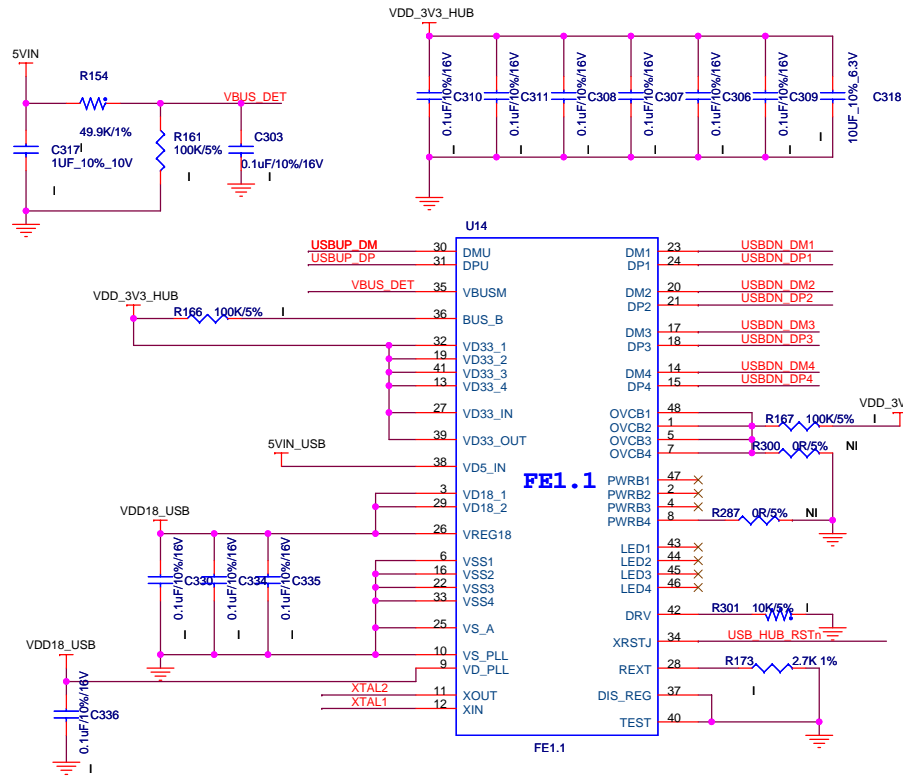

[5] USB_RSTn << R290_0R/5% NI USB_HUB_RSTn

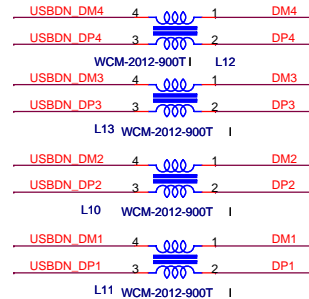

USB Up Stream

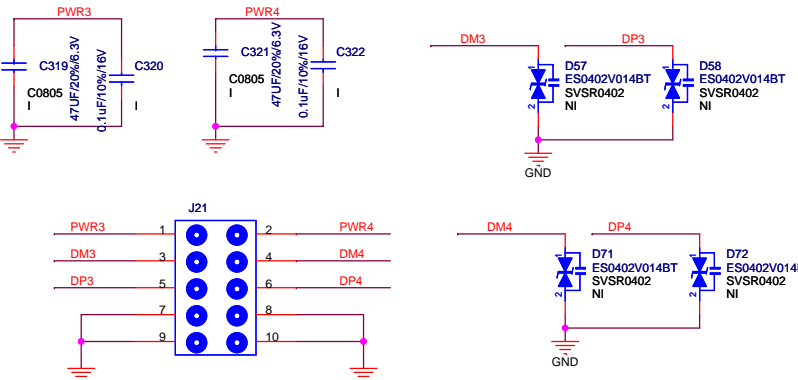
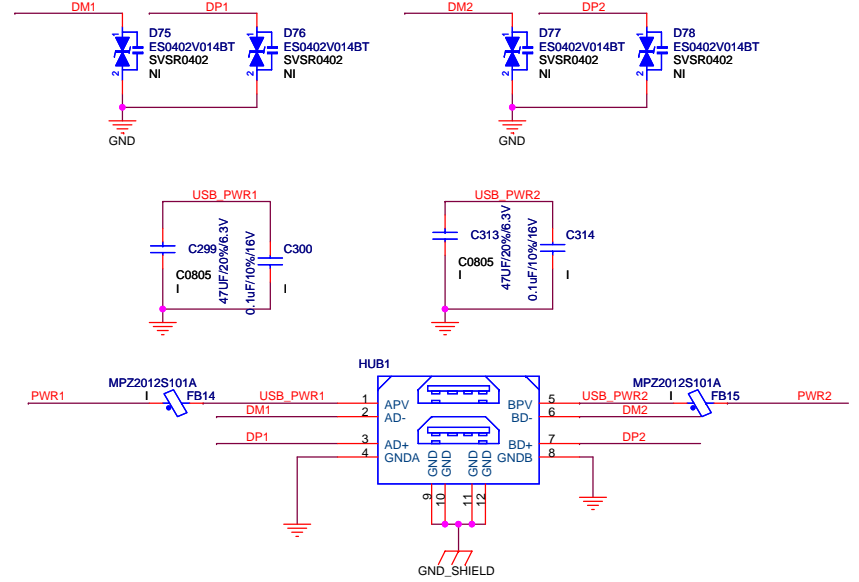
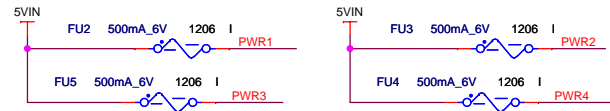
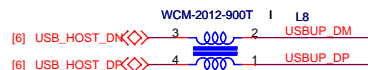

Design	<design>	Embest Tech Co. LTD		
Review	<review>	Title: MX6		
Authorize	<authorize>	Size	Doc Name	Ver.
Standardize	<standardize>	A3	16 USB HUB	X1
		Date	Tuesday, May 07, 2013	Sheet 16 of 17

LVDS INTERFACE

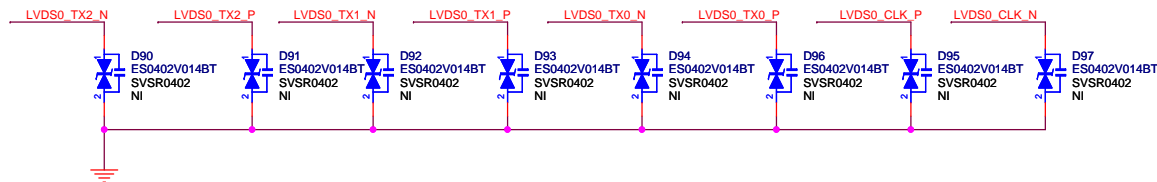
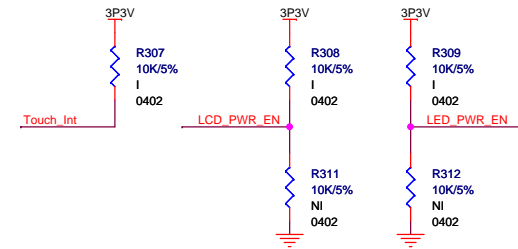
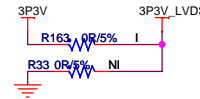
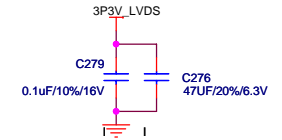
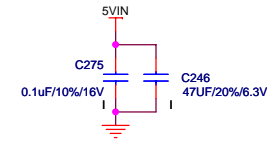
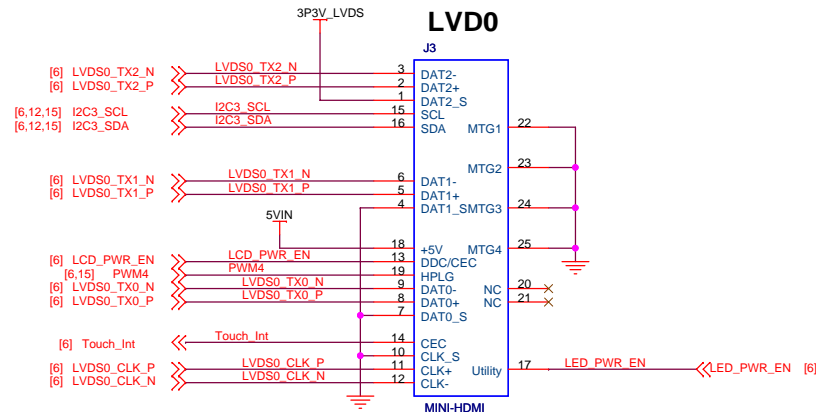

Design	<design>	Embest Tech Co. LTD		
Review	<review>			
Authorize	<authorize>	Size	Doc Name	Ver.
Standardize	<standardize>	A3	17 LVDS	X1
		Date	Tuesday, May 07, 2013	Sheet 17 of 17