

Mini8118

INDEX

SCHEMATIC	PAGE
01 Conver page	01
02.Schematic History	02
03.SYSTEM BLOCK	03
04.AM1808/LCD/SATA/VPIF/AUDIO	04
05.AM1808/Memory/USB/JTAG	05
06.AM1808 POWER	06
07.DDR2	07
08.Nand Flash	08
09.POWER	09
10.CoreBoard B2B	10

Design	Gray	Embest Technology Co., Ltd		
Review	Gary Xu	Title Mini8118		
Authorize	Gray	Size	Doc Name	Ver.
Standardize	<standardize>	A3	01.CONVER PAGE	X2
		Date	Monday, September 17, 2012	Sheet 1 of 10

Schematic History

2012-05-10

- 1.Change Reset Function
- 2.Remove reserve Function

Design	Gray	Embest Technology Co., Ltd		
Review	Gary Xu	Title Mini8118		
Authorize	Gray	Size	Doc Name	Ver.
Standardize	<standardize>	A3	02.Schematic History	X2
		Date	Monday, September 17, 2012	Sheet 2 of 10

Mini8118 Core-board

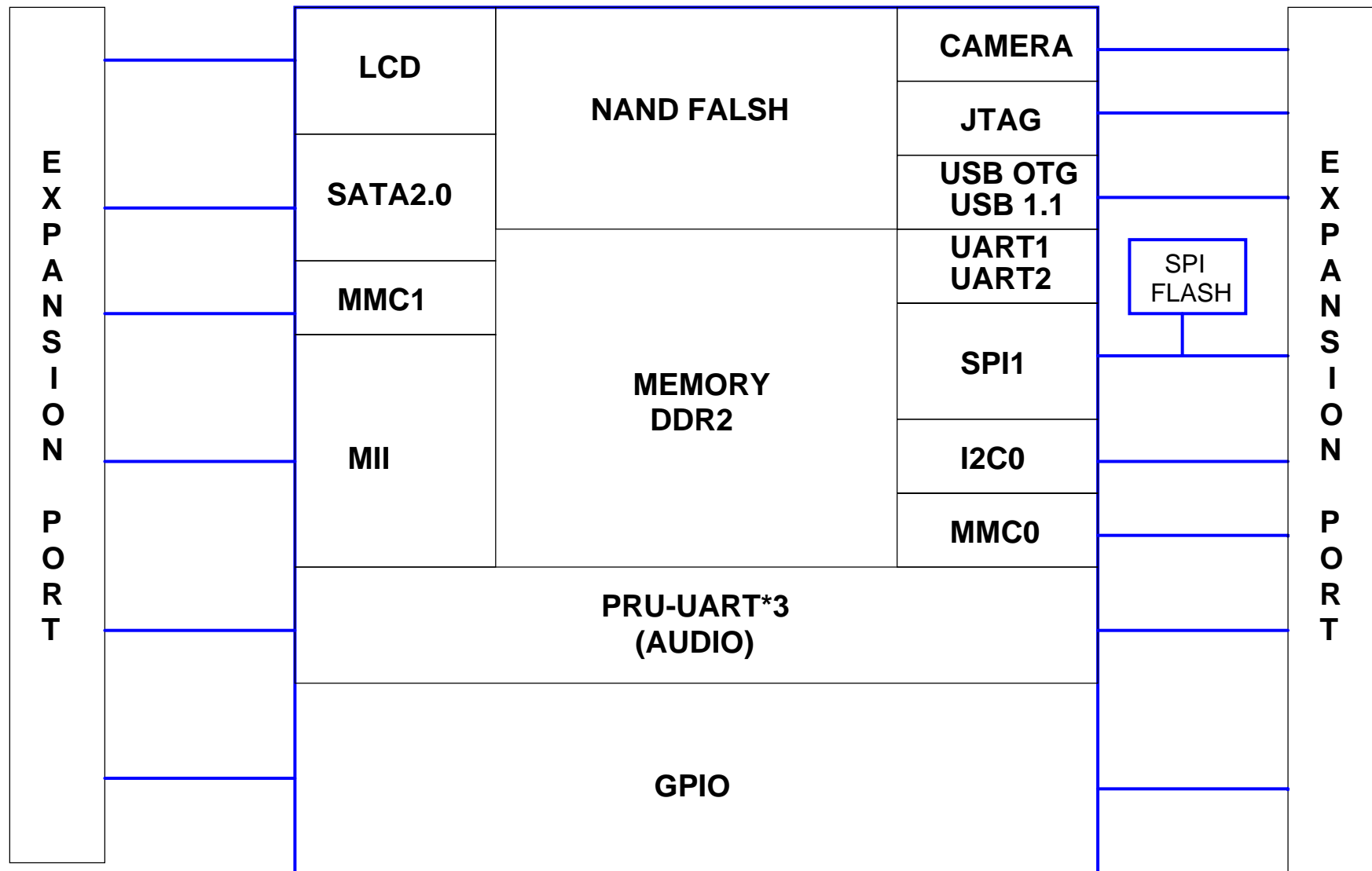

Design	Gray	Embest Technology Co., Ltd		
Review	Gary Xu	Title Mini8118		
Authorize	Gray	Size	Doc Name	Ver.
Standardize	<standardize>	A3	03.SYSTEM BLOCK	X2
		Date	Monday, September 17, 2012	Sheet 3 of 10

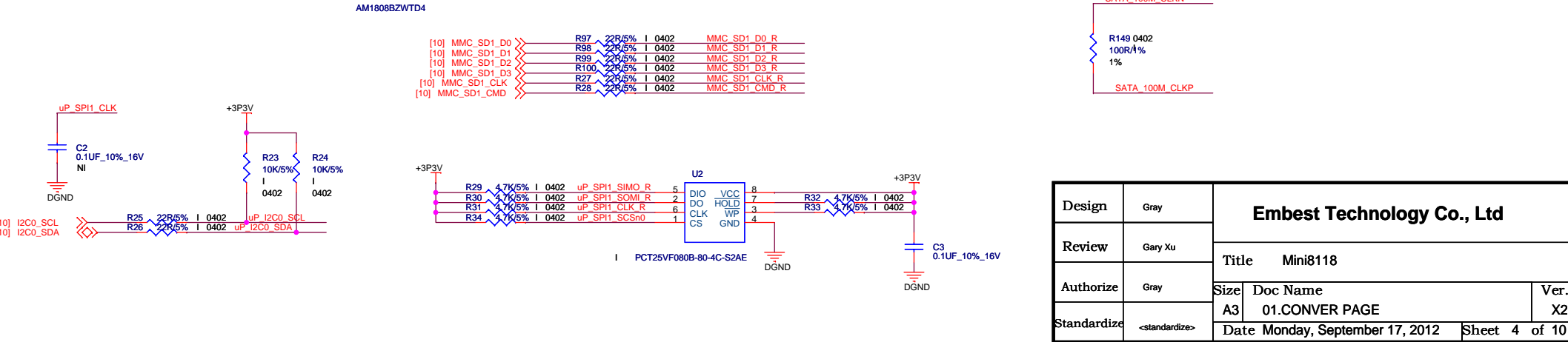
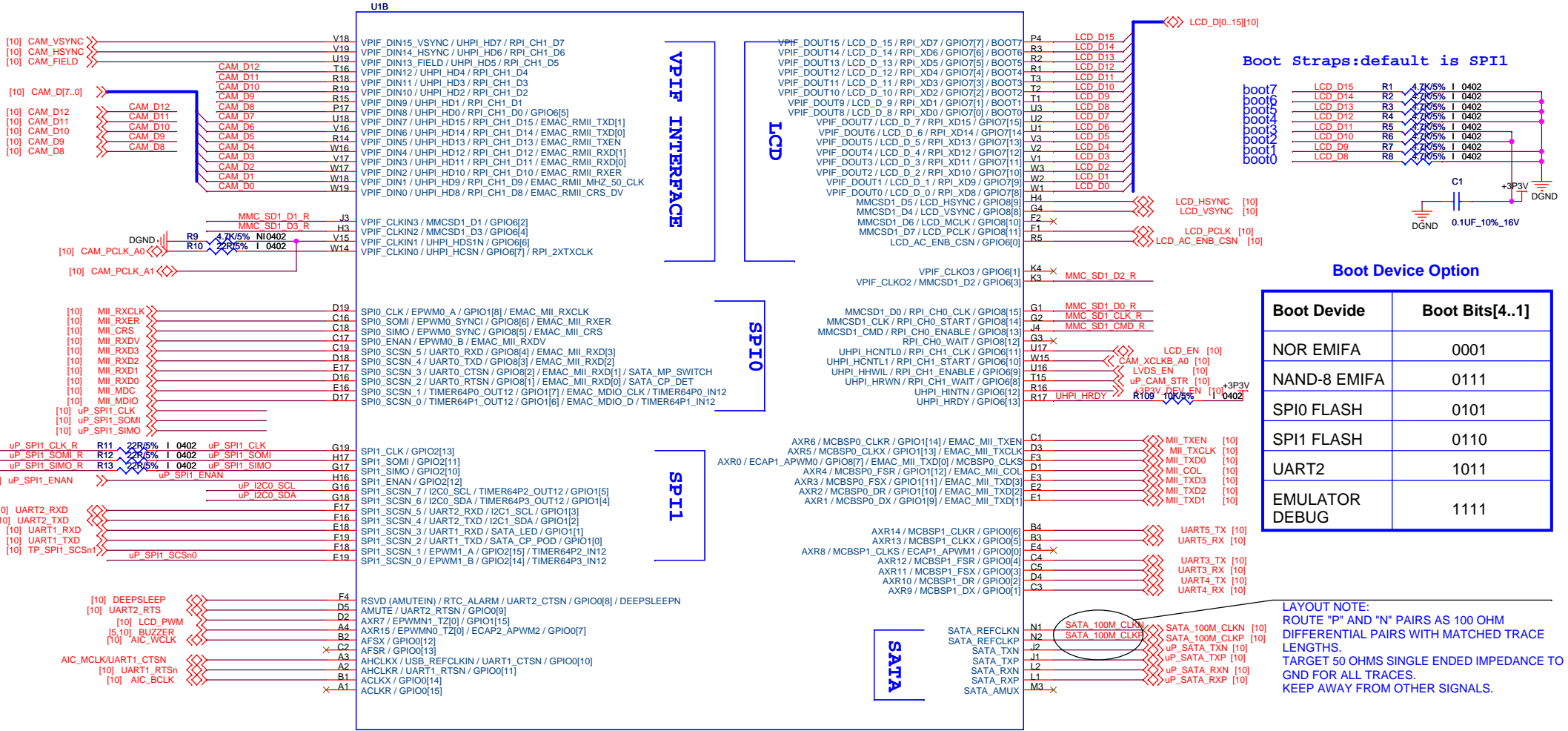

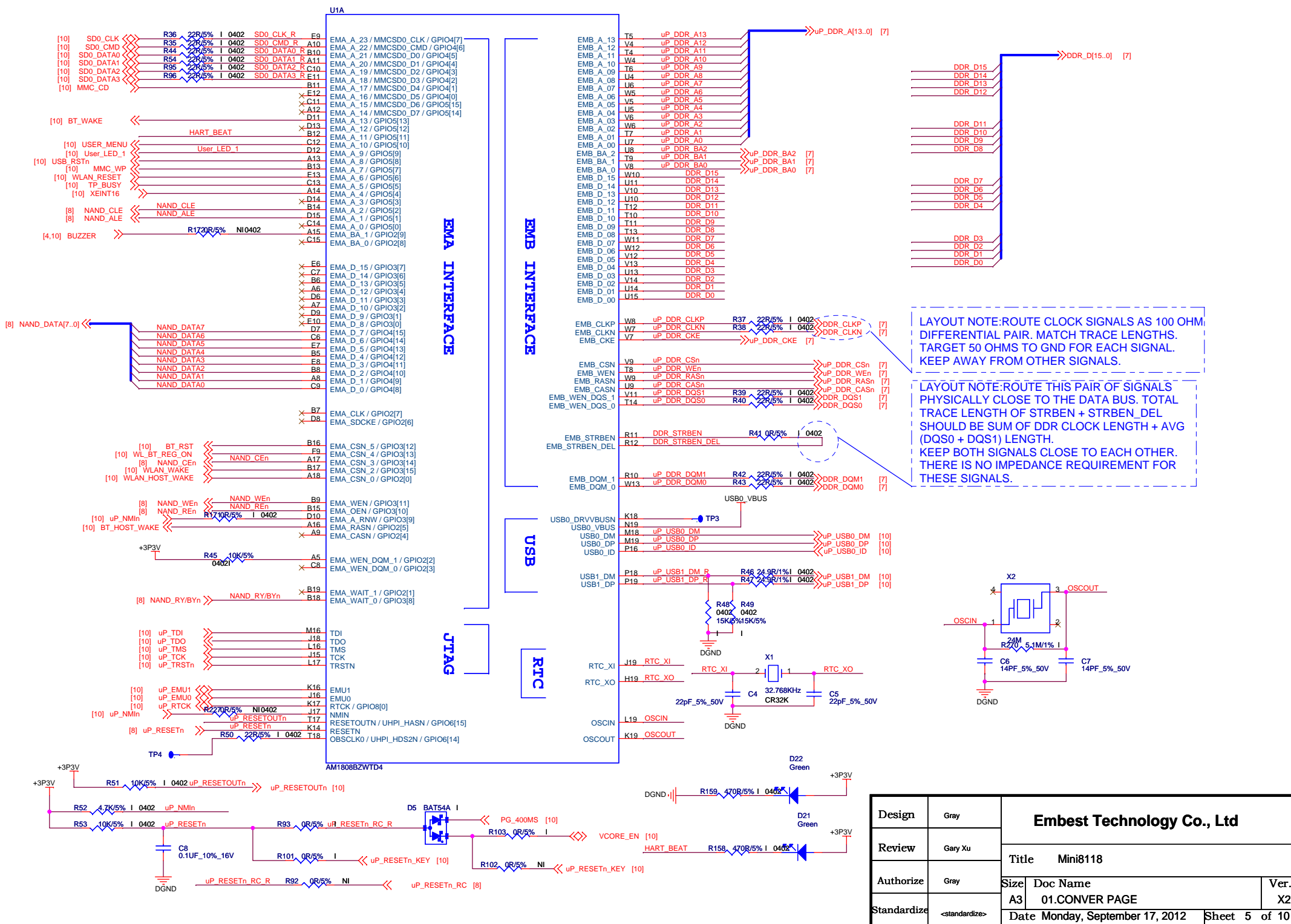

LAYOUT NOTE: ROUTE CLOCK SIGNALS AS 100 OHM DIFFERENTIAL PAIR. MATCH TRACE LENGTHS. TARGET 50 OHMS TO GND FOR EACH SIGNAL. KEEP AWAY FROM OTHER SIGNALS.

LAYOUT NOTE: ROUTE THIS PAIR OF SIGNALS PHYSICALLY CLOSE TO THE DATA BUS. TOTAL TRACE LENGTH OF STRBEN + STRBEN_DEL SHOULD BE SUM OF DDR CLOCK LENGTH + AVG (DQS0 + DQS1) LENGTH. KEEP BOTH SIGNALS CLOSE TO EACH OTHER. THERE IS NO IMPEDANCE REQUIREMENT FOR THESE SIGNALS.

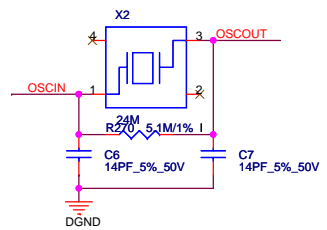

Design	Gray	Embest Technology Co., Ltd		
Review	Gary Xu			
Authorize	Gray	Title	Mini8118	
Standardize	<standardize>	Size	Doc Name	Ver.
		A3	01.CONVER PAGE	X2
		Date	Monday, September 17, 2012	Sheet 5 of 10

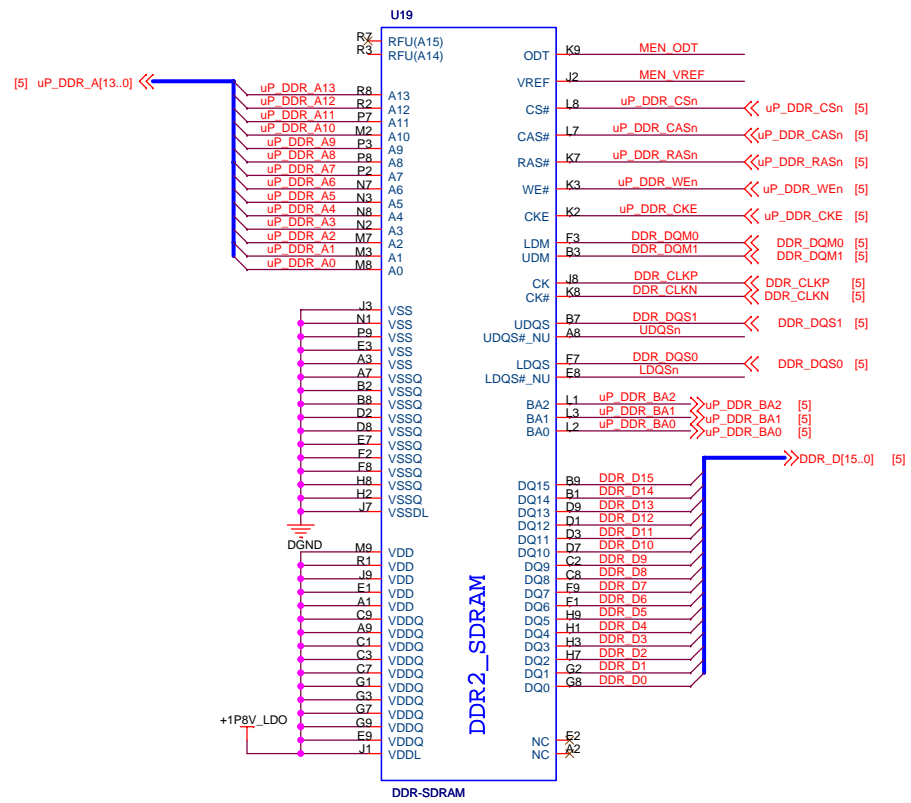
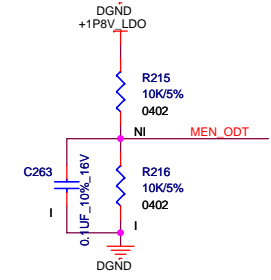
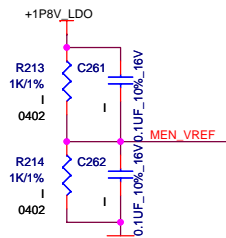
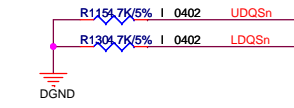
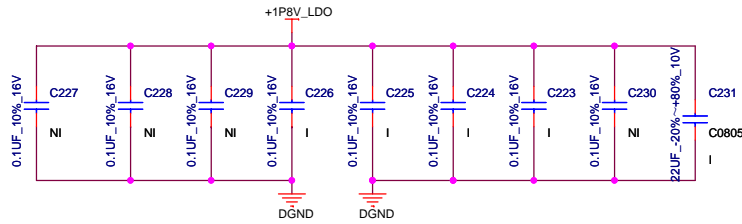

Design	Gray	Embest Technology Co., Ltd		
Review	Gary Xu			
Authorize	Gray	Title Mini8118		Ver. X2
Standardize	<standardize>	Size A3	Doc Name 01.CONVER PAGE	
		Date Monday, September 17, 2012	Sheet 7 of 10	

NAND FLASH

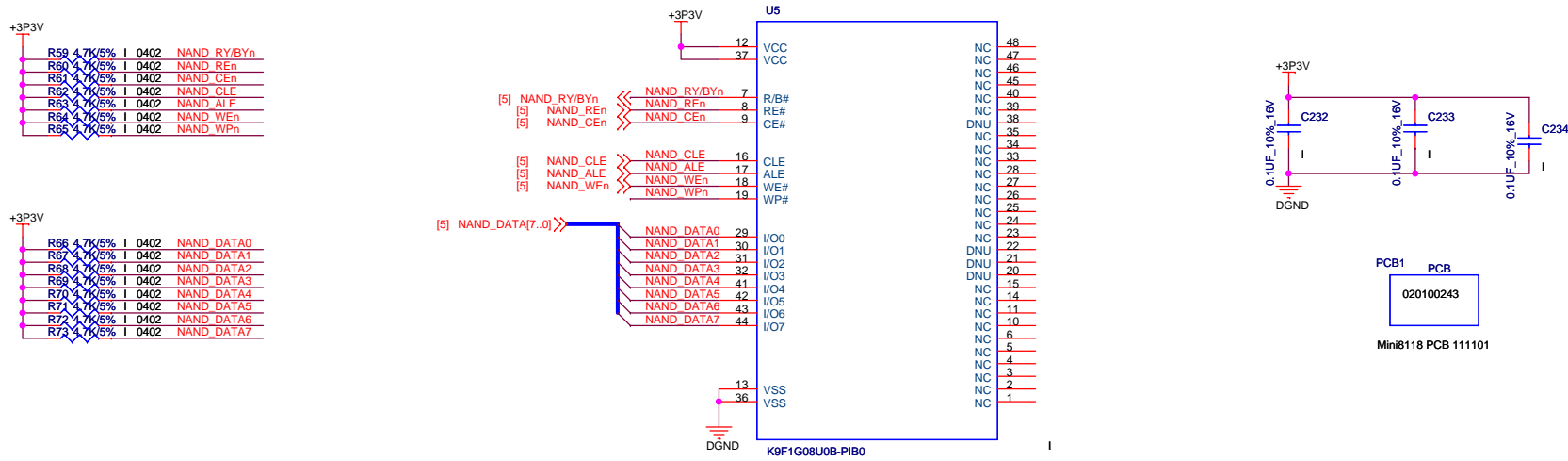

RESERVE

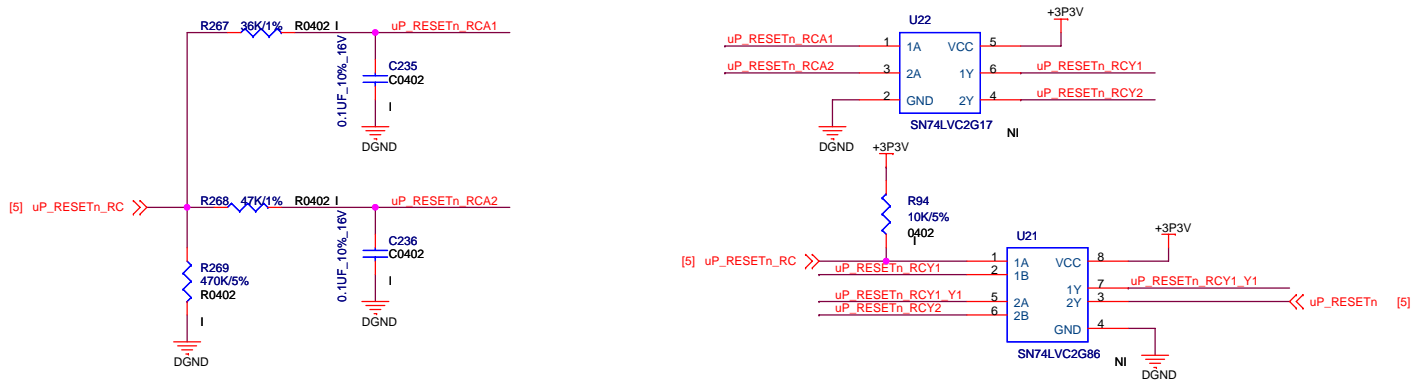

Design	Gray	Embest Technology Co., Ltd		
Review	Gary Xu			
Authorize	Gray	Title	Mini8118	
Standardize	<standardize>	Size	Doc Name	Ver.
		A3	01.CONVER PAGE	X2
		Date	Monday, September 17, 2012	Sheet 8 of 10

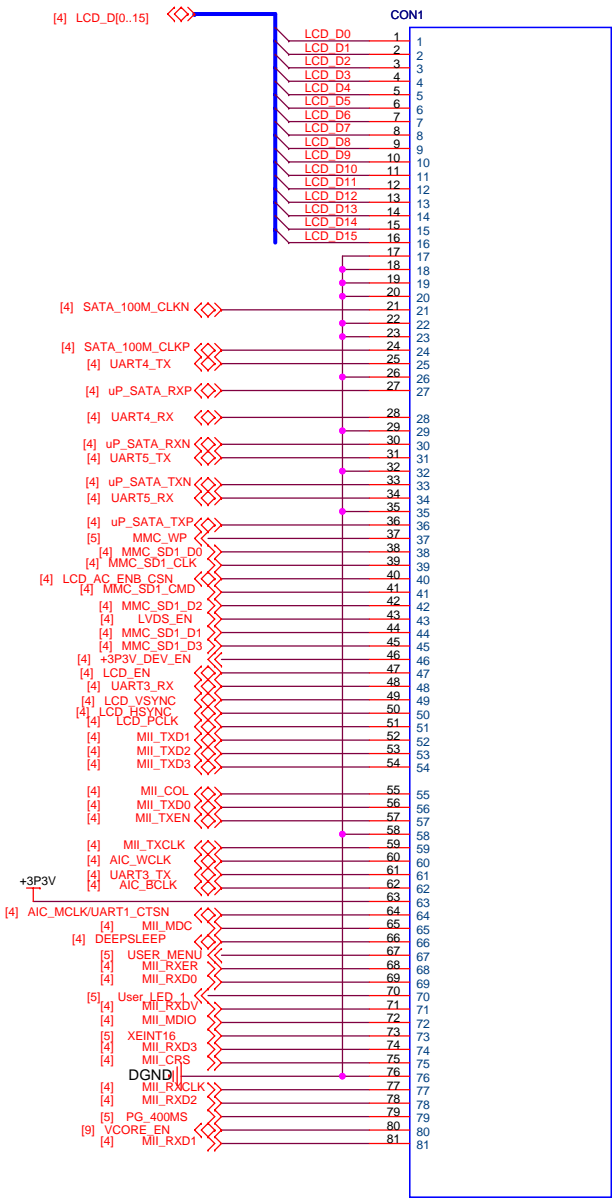

Con_3R_81P

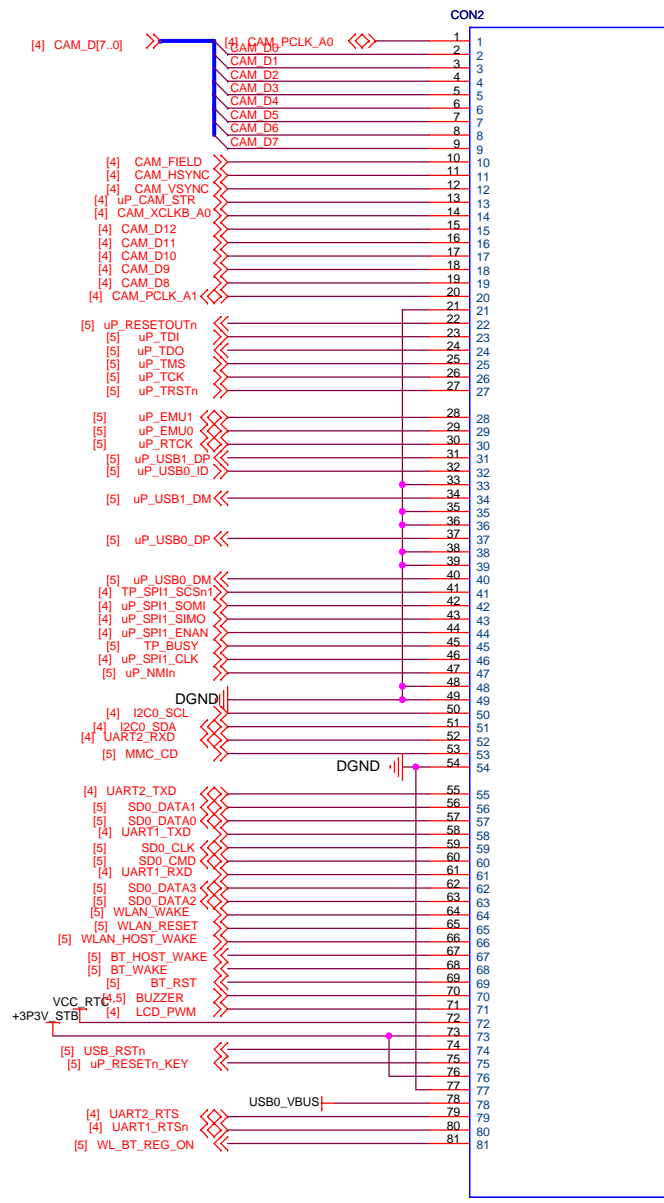

Con_3R_81P

Design	Gray	Embest Technology Co., Ltd		
Review	Gary Xu			
Authorize	Gray	Title Mini8118		Ver.
Standardize	<standardize>	Size A3	Doc Name 01.CONVER PAGE	X2
		Date Monday, September 17, 2012	Sheet 10 of 10	