

BB-EPH1800 151015

BB-PH1800

SHEET	SHEET NAME
01	INDEX
02	BLOCK DIAGRAM
03	BTB CONN
04	POWER
05	SD/TF CARD
06	RS232 & SPI to RS485
07	RS485/CAN
08	CAM/LCD/RTC
09	VGA/HDMI
10	USB OTG/HUB
11	ETHERNET
12	AUDIO
13	WIFI
14	MISC
15	REVISION HISTORY

Revision History

DATE	REVISION	DESCRIPTION
15 July 2015	BB-PH1800 150700	Initial Release
15 Oct 2015	BB-PH1800 151015	

BB-EPH1800 BLOCK DIAGRAM

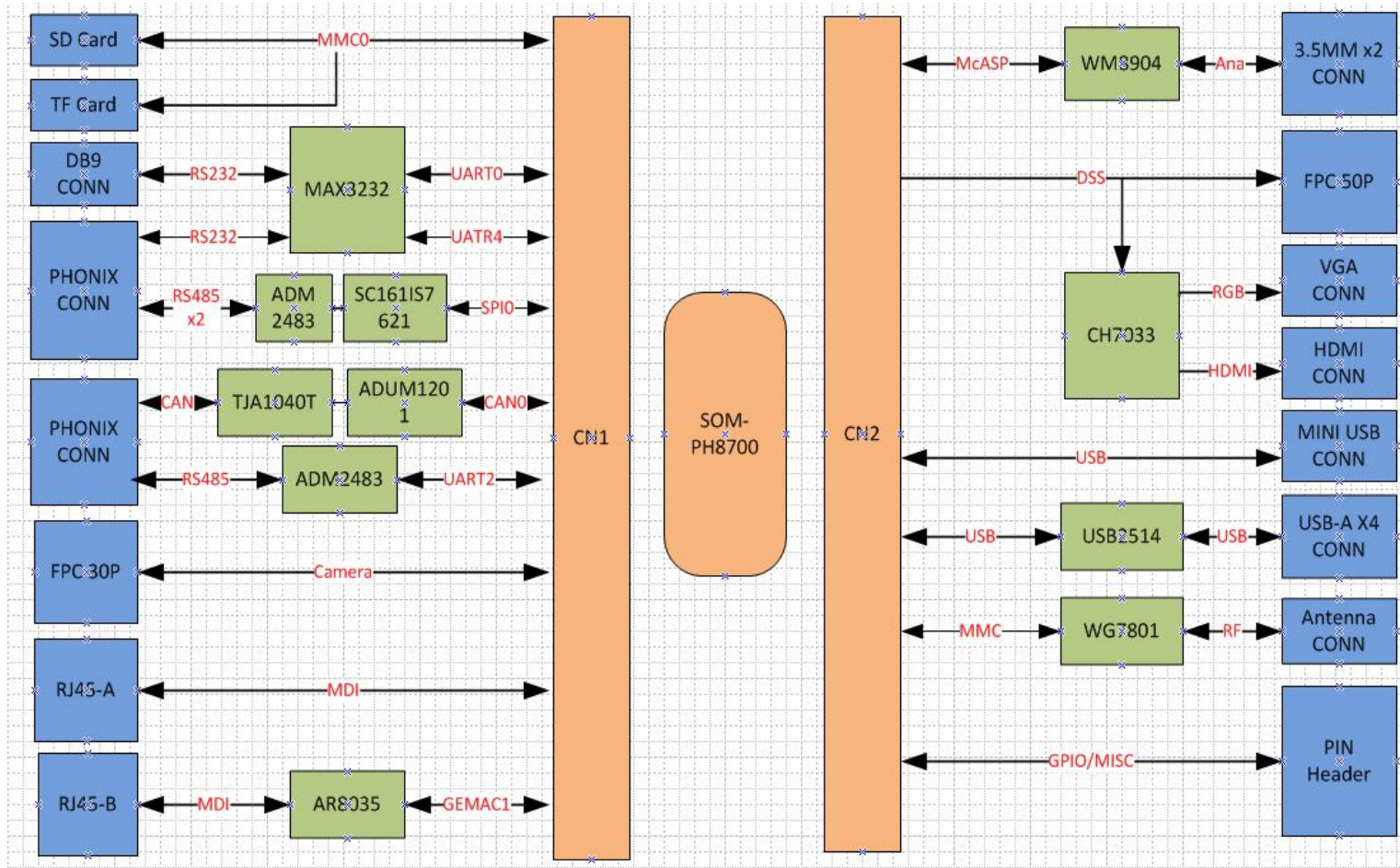

VSYSTEM: 12V, MAX 14.4V

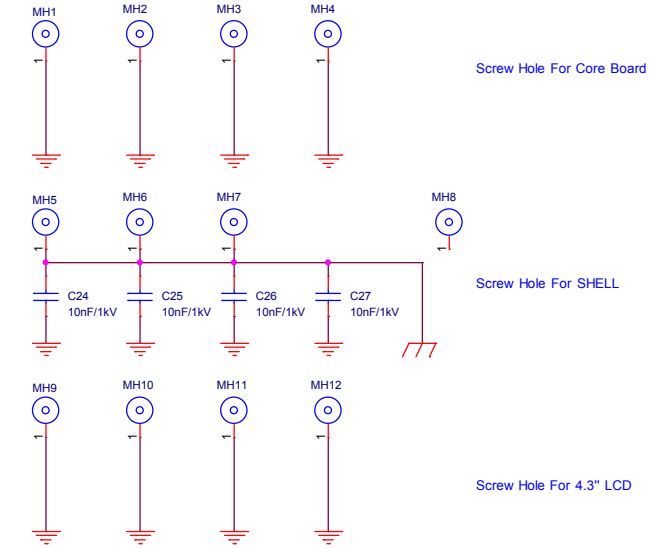
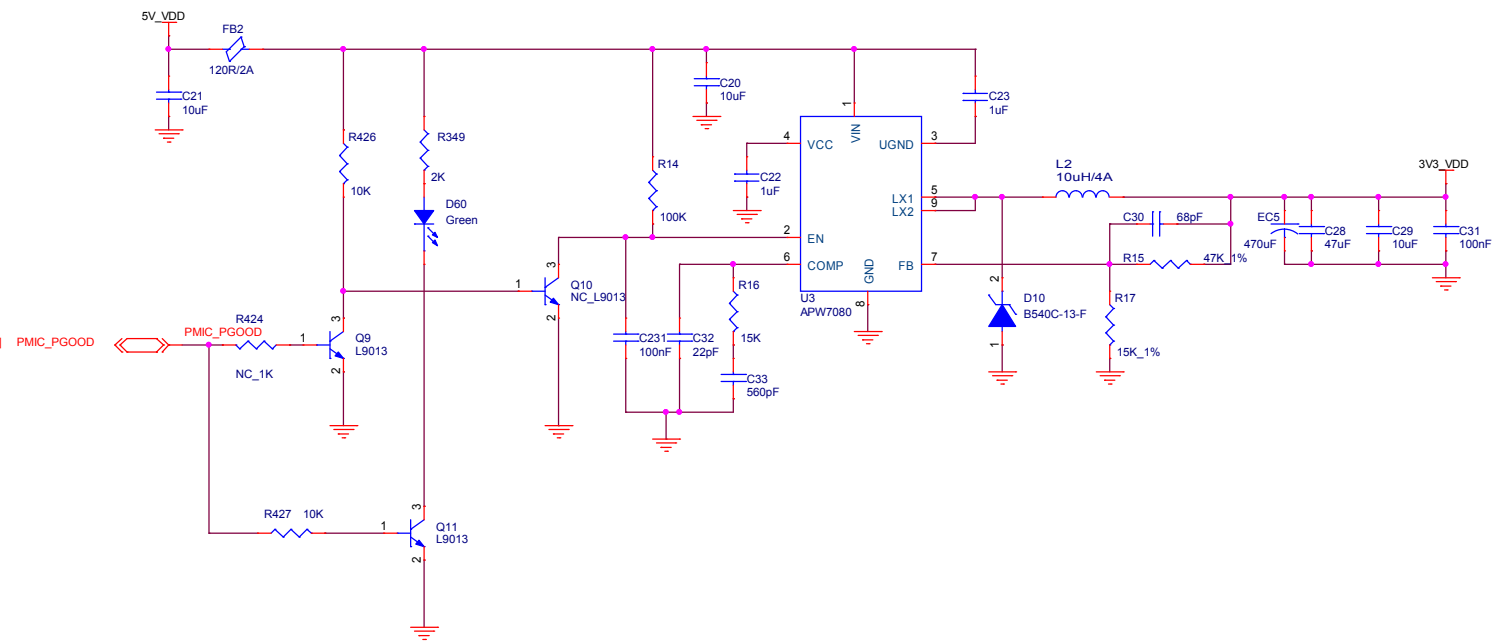
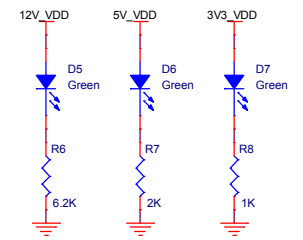
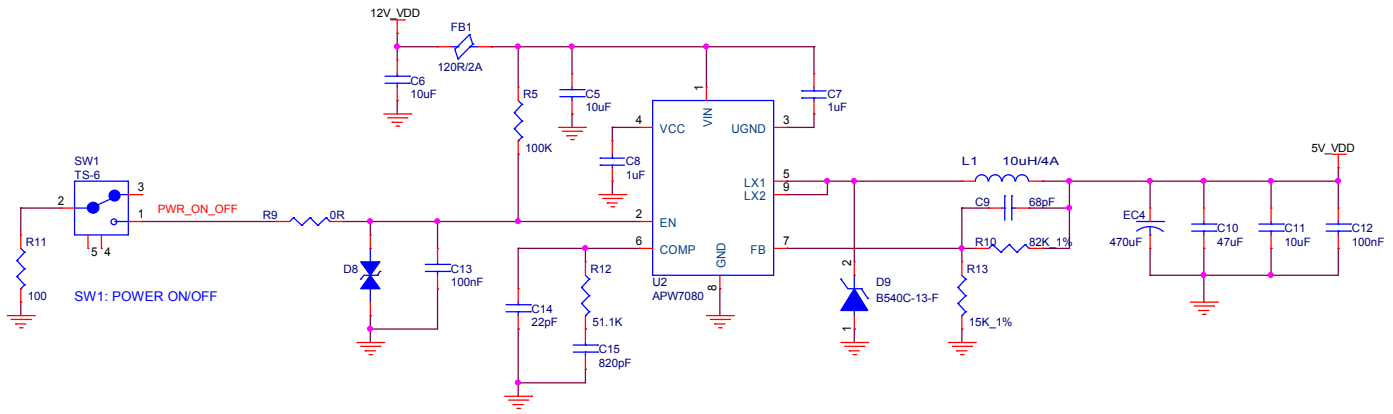
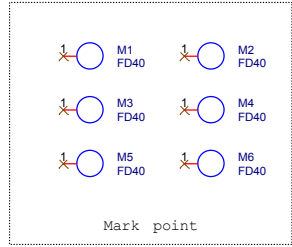
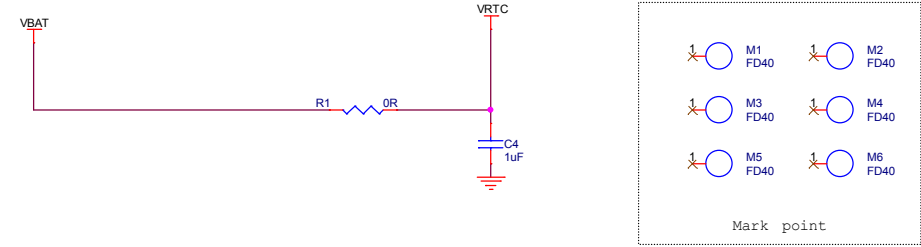
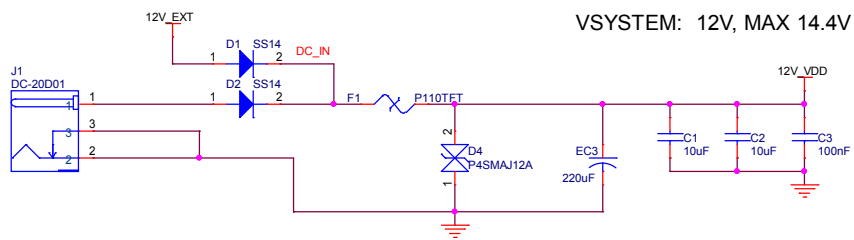

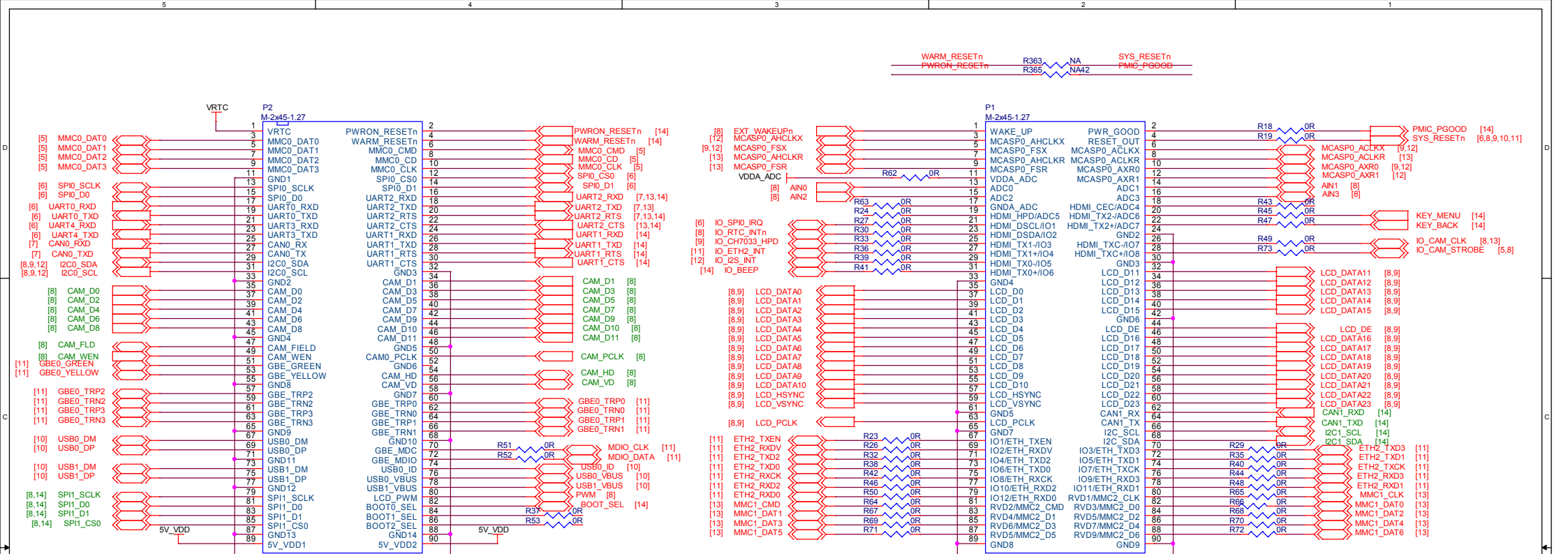

Note:

GBE0_GREEN/GBE0_YELLOW LOW ACTIVE

I2S MASTER TO WM8904/HDMI

I2S SLAVER TO WIFI

BLUE: With Function Defined on IO Board, but no connection on Core Board

GREEN: With Function Defined on IO Board, connection on Core Board is another Function

RED: Function Defined on IO Board & Core Board is the Same

		http://www.embest-tech.com	
		Title: BB-EPH1800 151015	
Size: A3	Document Number: 04_BT_B Connectors	Rev: V1.1	
Draw By: Tony	Date: Thursday, March 03, 2016	Sheet: 4 of 15	

MicroSD CARD

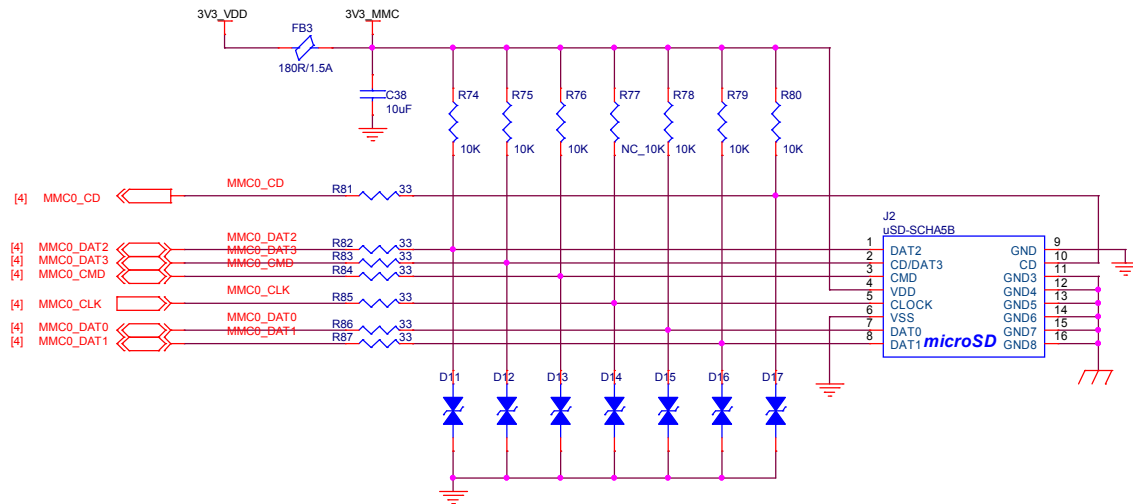

SD CARD

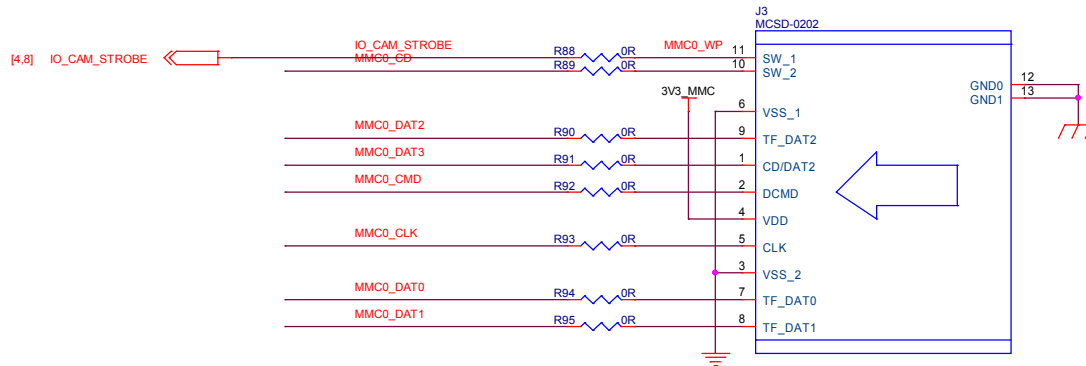

Note:

Micro SD & SD Card Share the Same MMC0 Interface
They can't access at the same time.

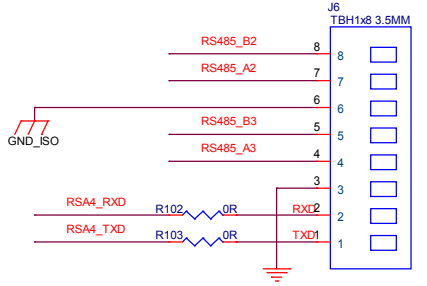
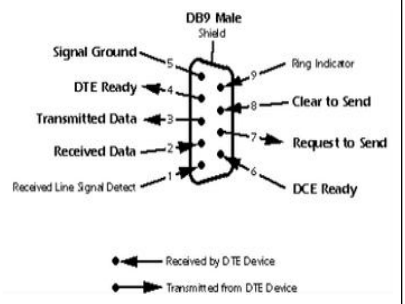
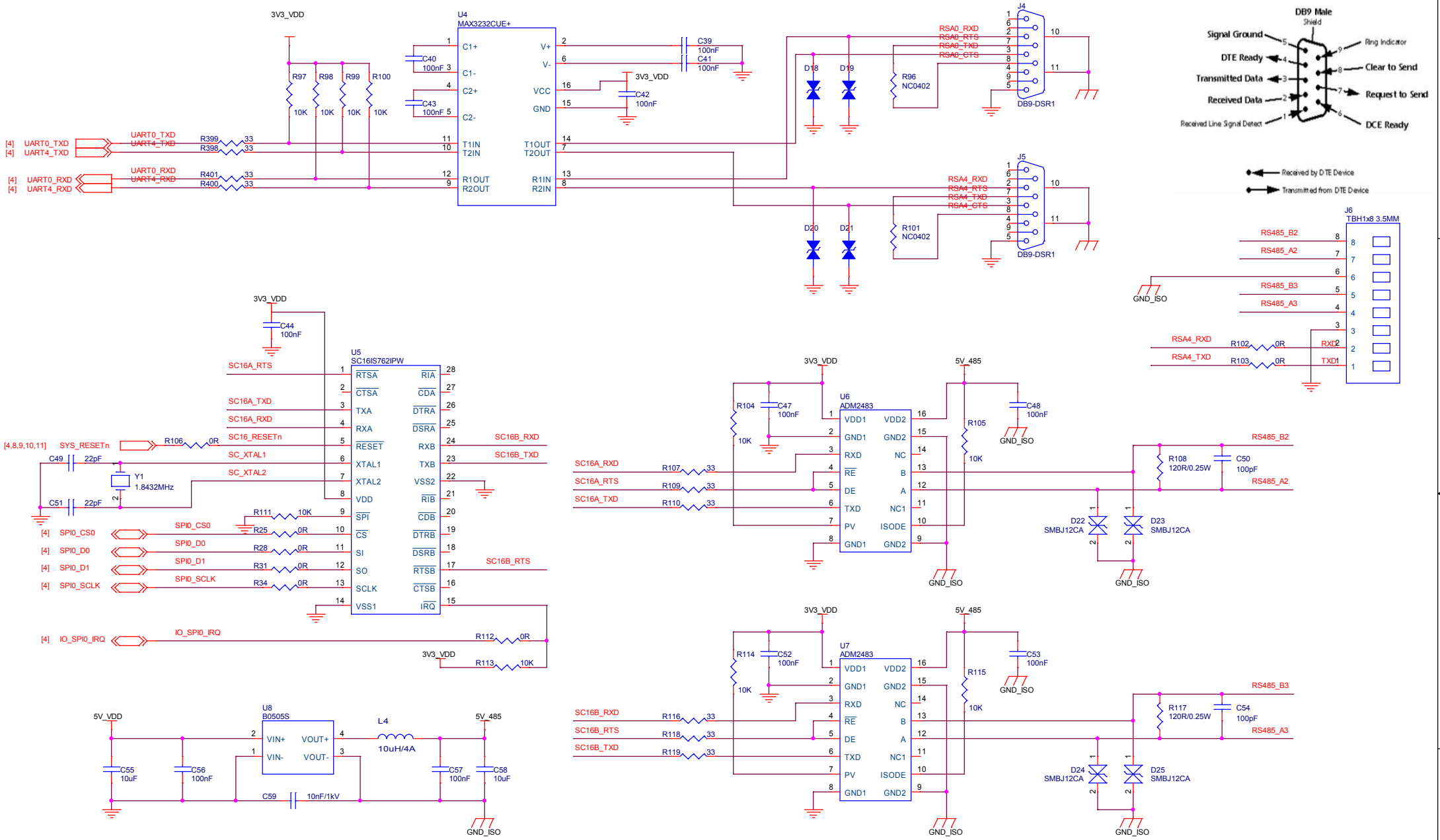

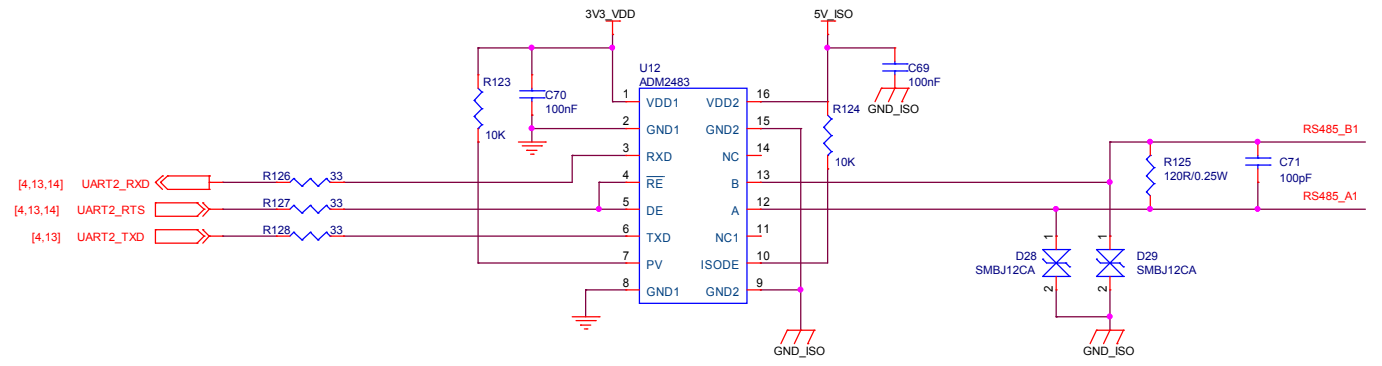
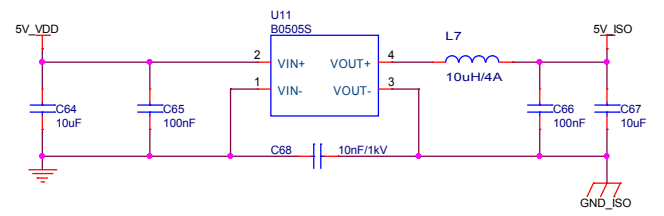
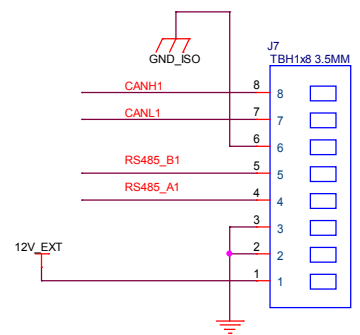
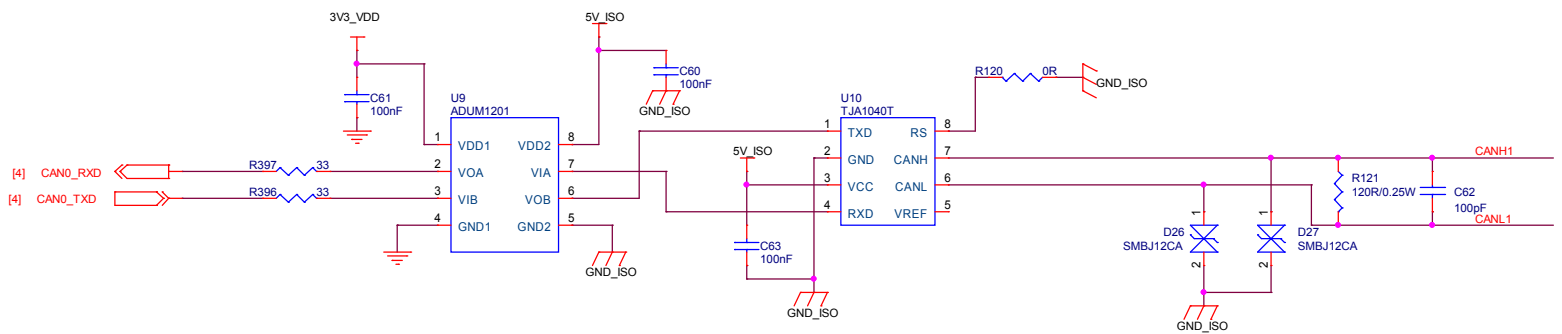

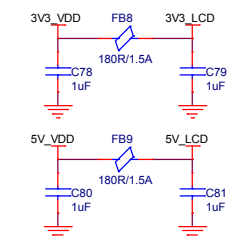
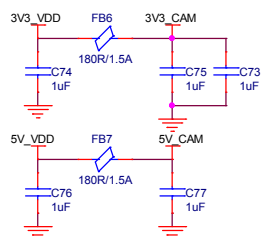
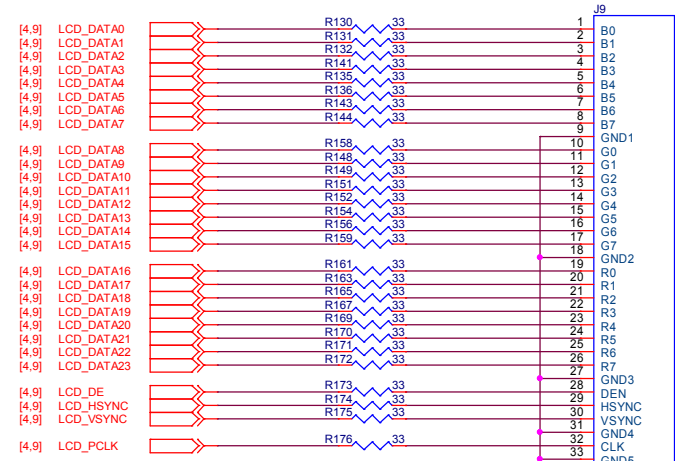
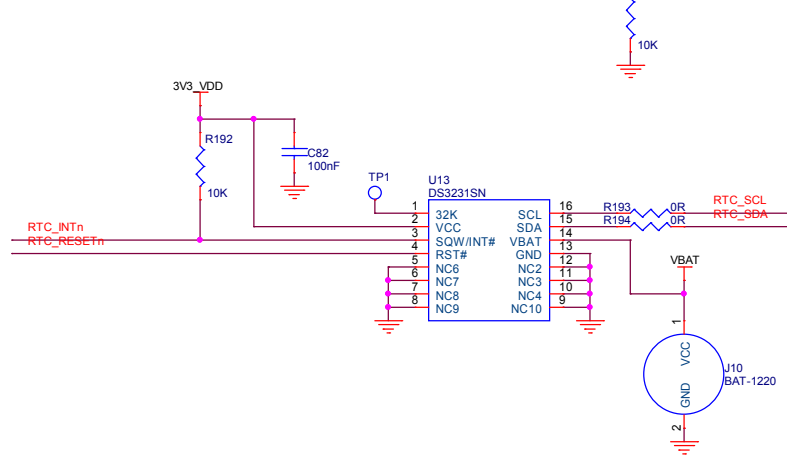
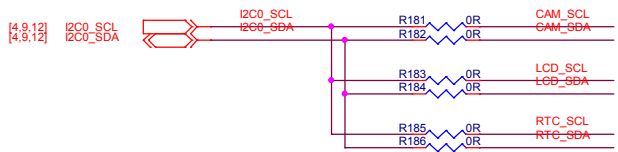
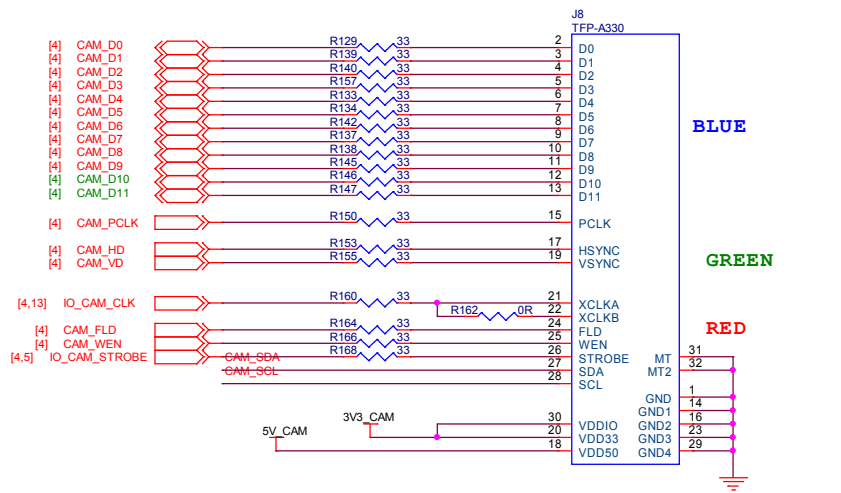

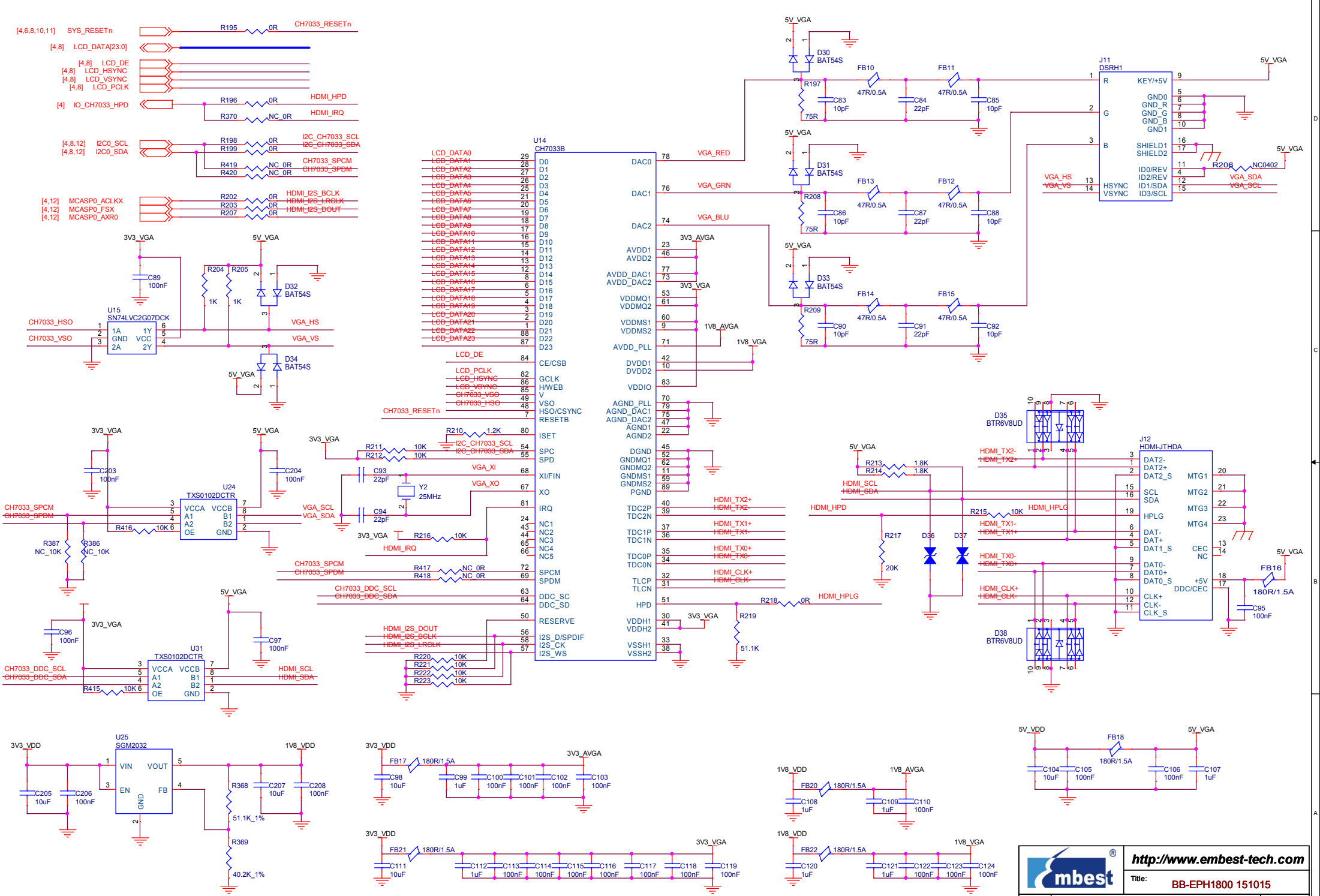

CH7033B

LCD_DATA0	29	D0	78	VGA_RED
LGD_DATA01	28	D1	76	VGA_GRN
LGD_DATA2	27	D2	74	VGA_BLU
LGD_DATA3	26	D3		
LGD_DATA4	25	D4		
LGD_DATA5	24	D5		
LGD_DATA6	23	D6		
LGD_DATA7	22	D7		
LGD_DATA8	21	D8		
LGD_DATA9	20	D9		
LGD_DATA10	19	D10		
LGD_DATA11	18	D11		
LGD_DATA12	17	D12		
LGD_DATA13	16	D13		
LGD_DATA14	15	D14		
LGD_DATA15	14	D15		
LGD_DATA16	13	D16		
LGD_DATA17	12	D17		
LGD_DATA18	11	D18		
LGD_DATA19	10	D19		
LGD_DATA20	9	D20		
LGD_DATA21	8	D21		
LGD_DATA22	7	D22		
LGD_DATA23	6	D23		

CH7033B

LCD_DE	84	CE/CSB	80	ISET
LCD_PCLK	82	GCLK	54	SPC
LGD_HSYNC	82	HWEB	55	SPD
LGD_VSYNC	85	HWEB	68	XI/FIN
CH7033_VSO	49	V	67	XO
CH7033_HSO	48	VSO	81	IRQ
CH7033_RESETn	7	HSD/CSYNC	24	NC1
		RESETB	43	NC2
			44	NC3
			65	NC4
			66	NC5
			72	SPCM
			69	SPDM
			63	DDC_SCL
			64	DDC_SD
			50	RESERVE
			56	HDMI_I2S_DOUT
			58	HDMI_I2S_BCLK
			57	HDMI_I2S_LRCLK
				I2S_WS

embest <http://www.embest-tech.com>

Title: **BB-EPH1800 151015**

Size: A3	Document Number: 08_VGA/HDMI	Rev: V1.1
Draw By: Tony	Date: Thursday, March 03, 2016	Sheet: 9 of 15

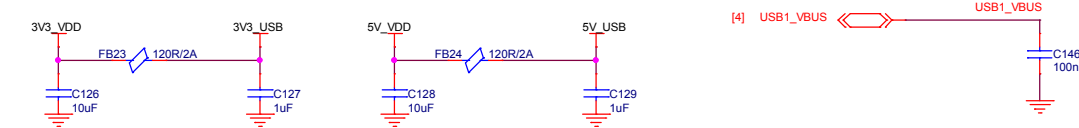
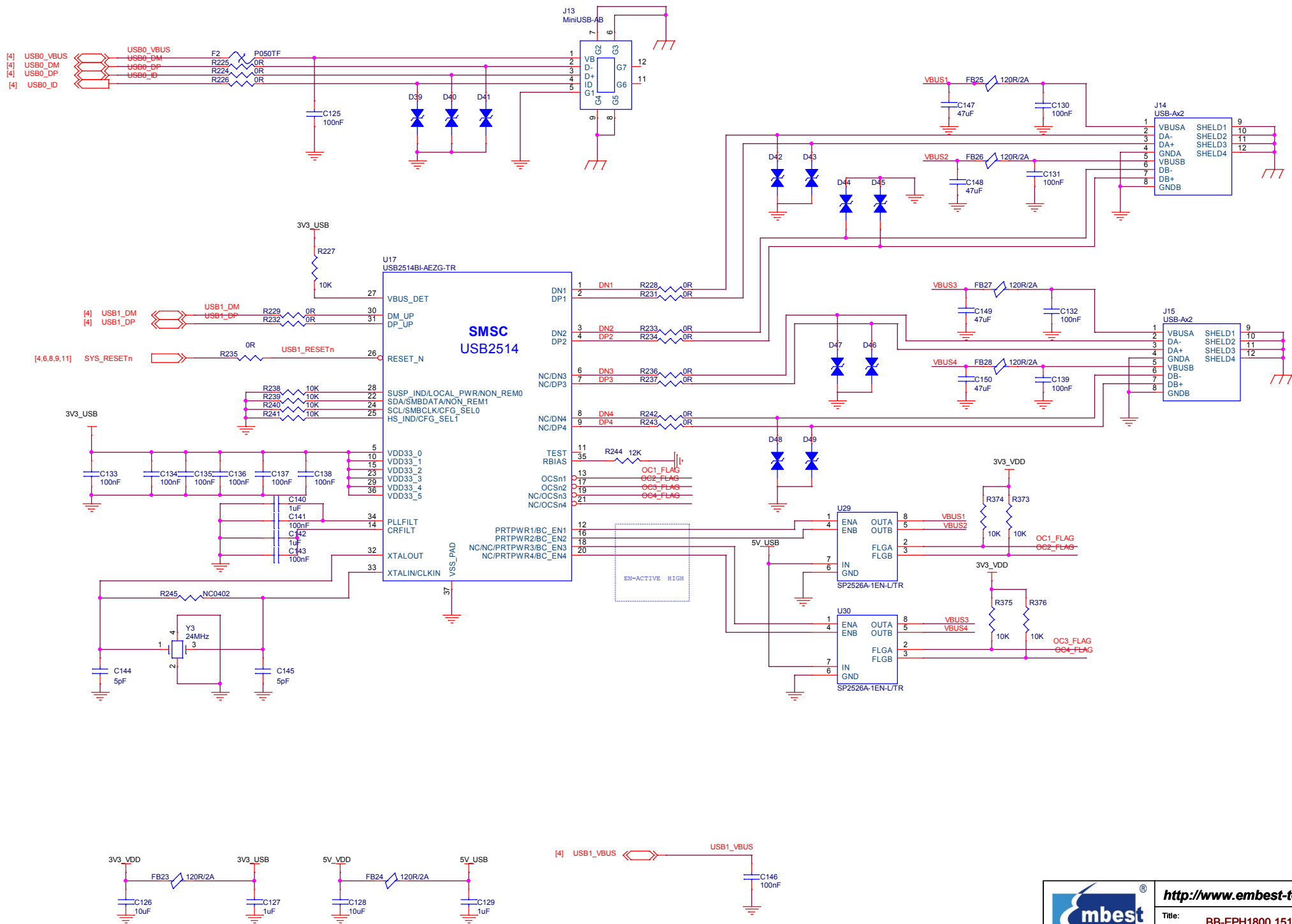

		http://www.embest-tech.com	
		Title: BB-EPH1800 151015	
Size: A3	Document Number: 10_USB OTG/HUB	Rev: V1.1	
Draw By: Tony	Date: Thursday, March 03, 2016	Sheet: 10 of 15	

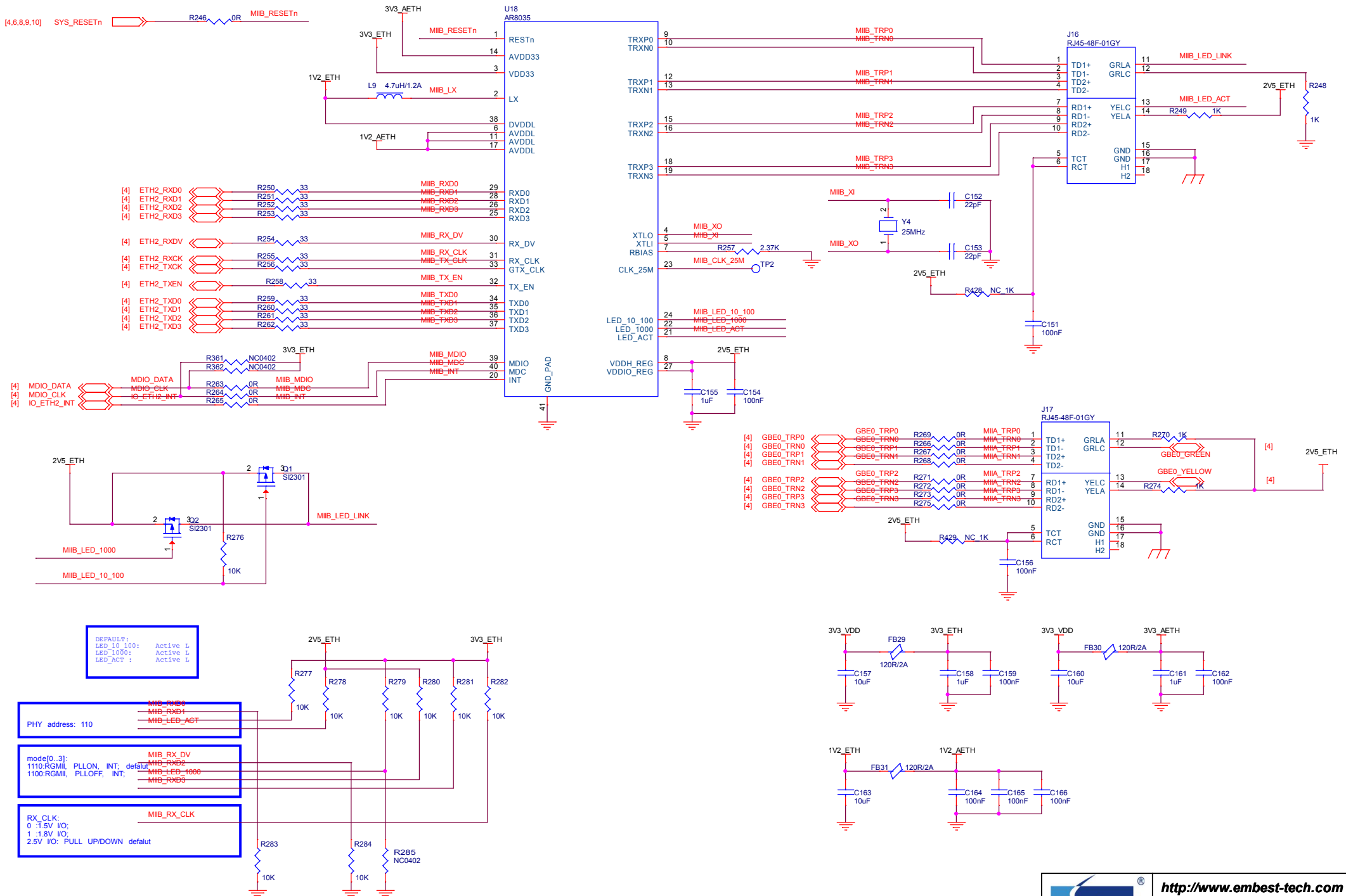

DEFAULT:
 LED_10_100: Active L
 LED_1000: Active L
 LED_ACT: Active L

PHY address: 110
 MIB_RXD3
 MIB_RXD1
 MIB_LED_ACT

mode[0..3]:
 1110:RGMII, PLLON, INT, default
 1100:RGMII, PLLOFF, INT,
 MIB_RX_DV
 MIB_RXD2
 MIB_LED_1000
 MIB_RXD3

RX_CLK:
 0 :1.5V IO;
 1 :1.8V IO;
 2.5V IO: PULL UP/DOWN default
 MIB_RX_CLK

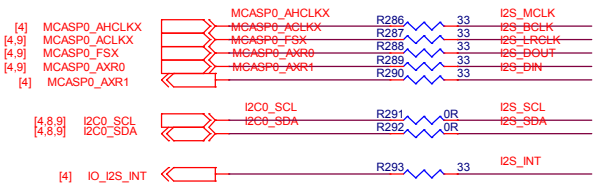

AUDIO OUT

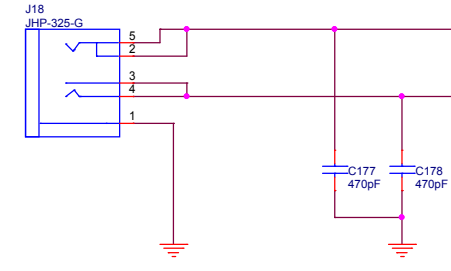

MIC

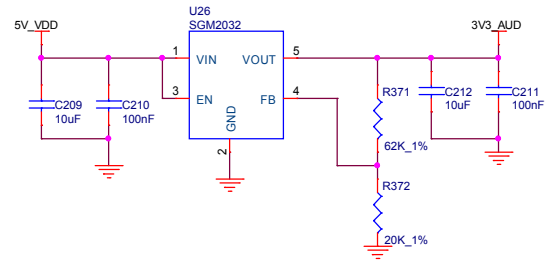
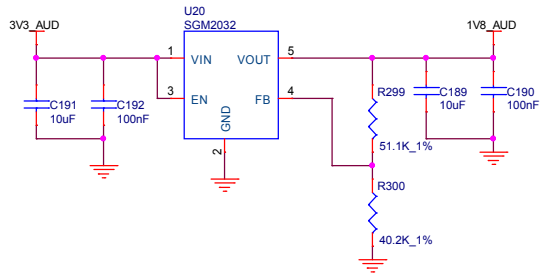
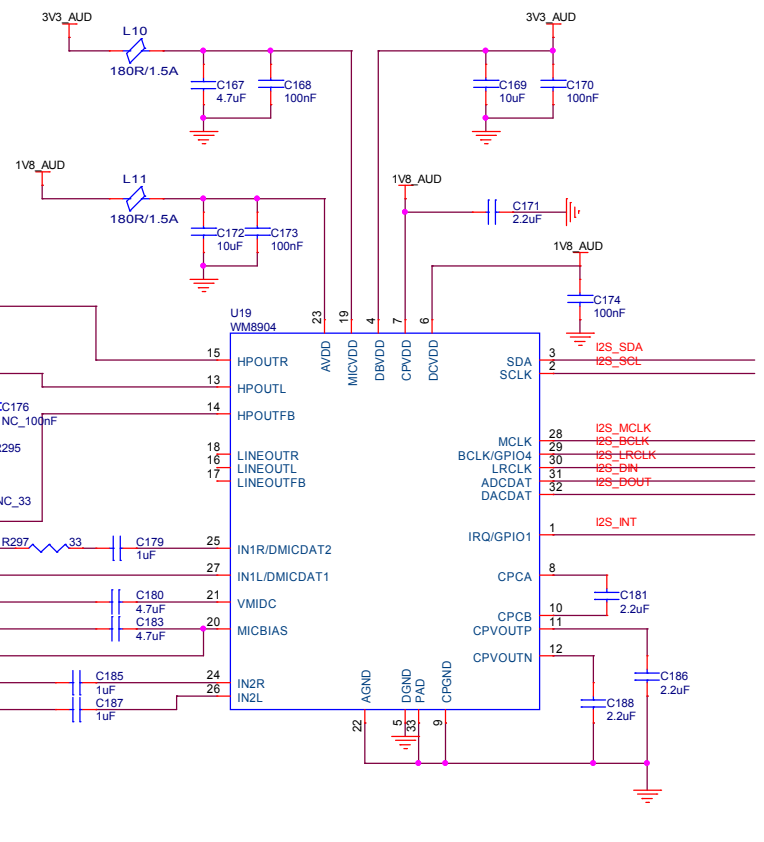
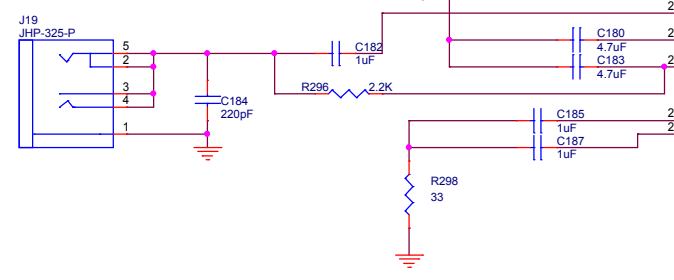

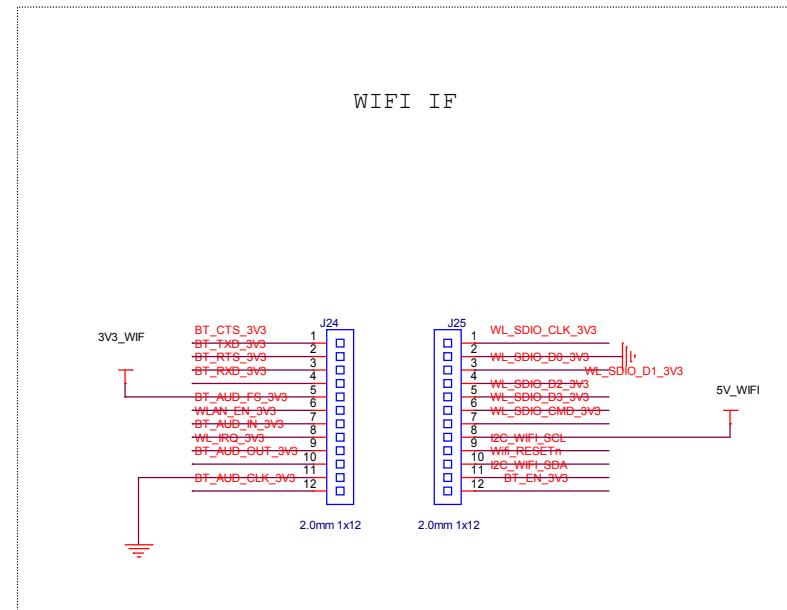
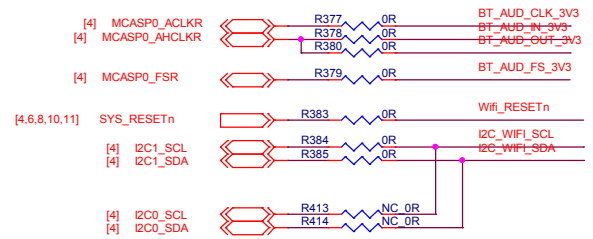
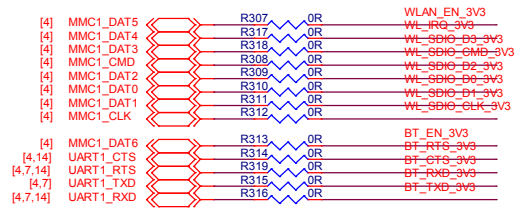

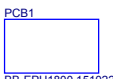
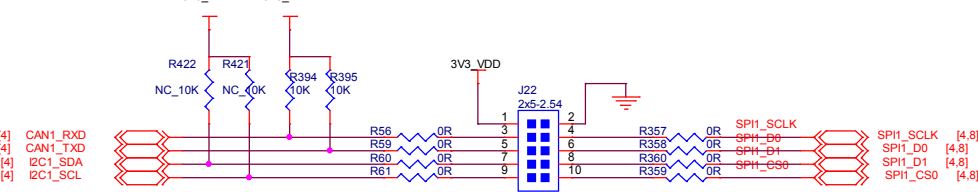
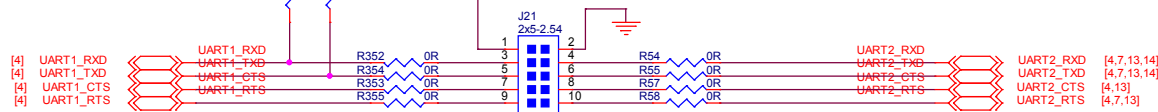
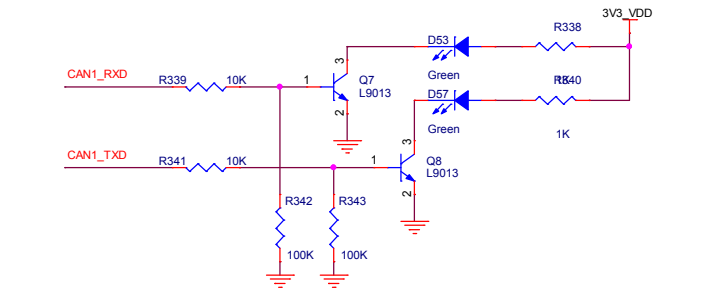
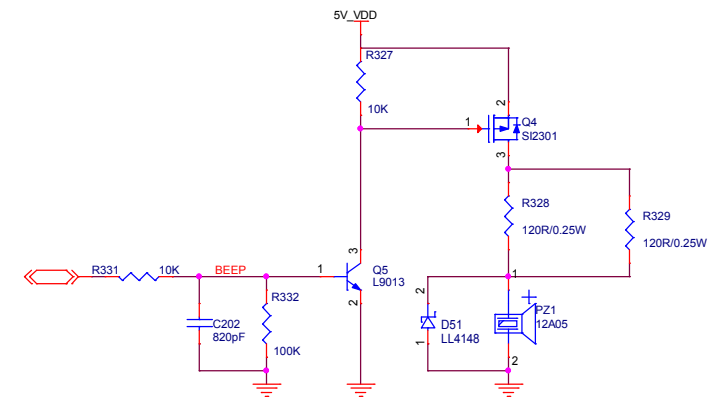
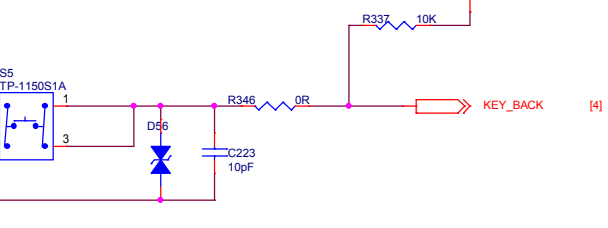
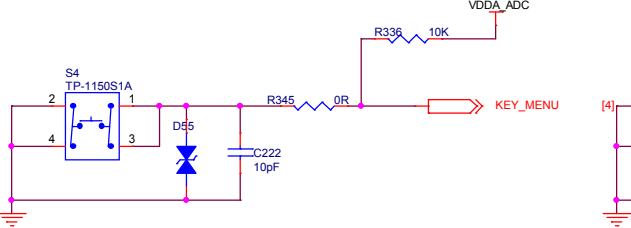
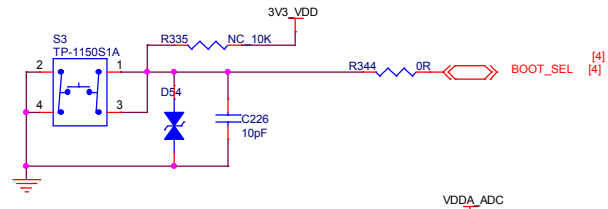
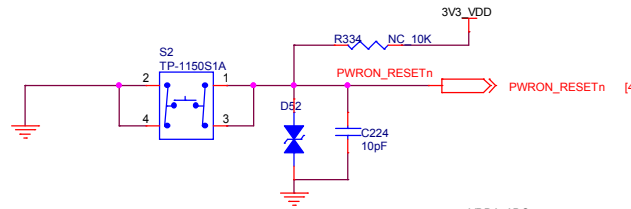
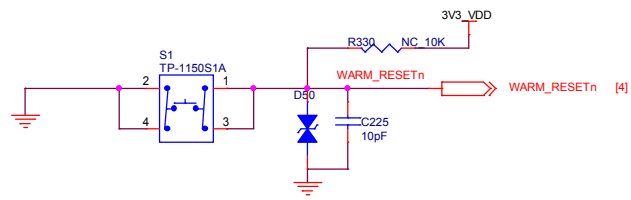

BB-PH1800 Revision History

BB-EPH1800 150600

BB-EPH1800 150601

		http://www.embest-tech.com	
		Title: BB-EPH1800 151015	
Size: A3	Document Number: 15_Revision History	Rev: V1.1	
Draw By: Tony	Date: Thursday, March 03, 2016	Sheet: 15 of 15	