

Design	<design>	<b>Embest Tech Co. LTD</b>		
Review	<review>	Title SBC9000		
Authorize	<authorize>	Size	Doc Name	Ver.
Standardize	<standardize>	A3	01 Cover Page	X1
		Date	Tuesday, January 27, 2015	Sheet 1 of 17

# Schematic History

2014-07-25

- Delete D49
- Modify Boot Configuration Text
- Change P/N of U5
- Change Net Name PWM4 to PWM3
- Interchange Connection of TX and RX Signal Group of SATA
- Modify CAN Module
- Modify Mini PCIe Module

2014-09-22

- Add mechanical holes

Design	<design>	<b>Embest Tech Co. LTD</b>		
Review	<review>	Title SBC9000		
Authorize	<authorize>	Size	Doc Name	Ver.
Standardize	<standardize>	A3	02 Schematic History	X1
		Date	Tuesday, January 27, 2015	Sheet 2 of 17

# Main Power

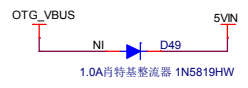
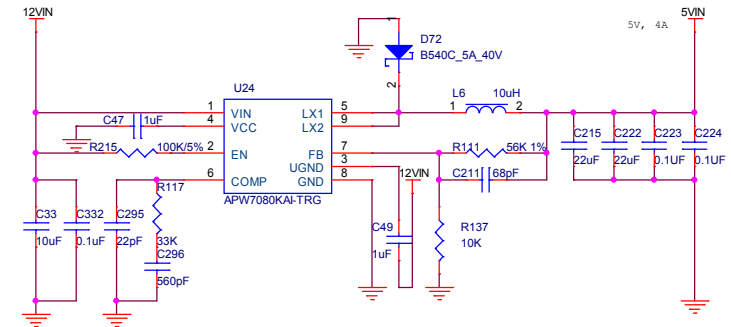
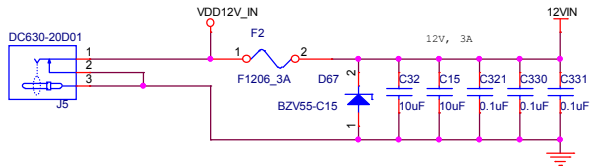

# LEDs

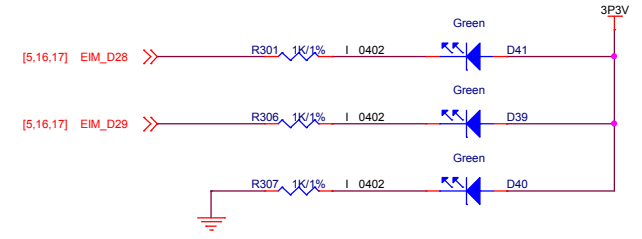

# RTC

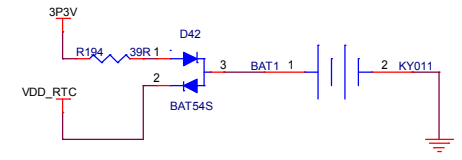

# Keys

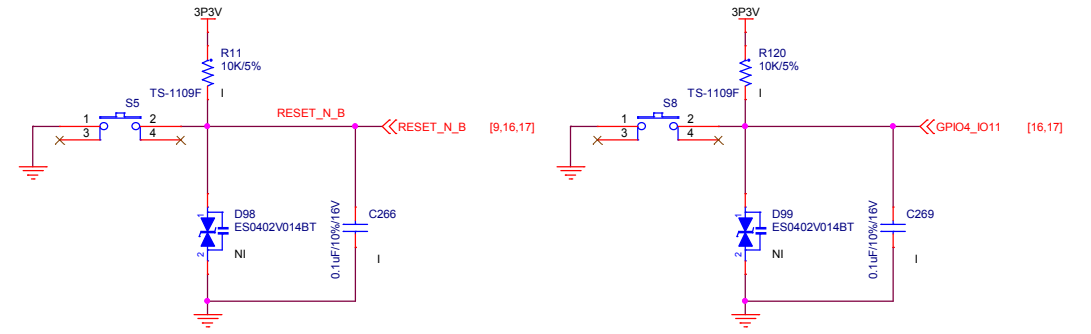

Design	<design>	<b>Embest Tech Co. LTD</b>		
Review	<review>			
Authorize	<authorize>	Title SBC9000		
Standardize	<standardize>	Size A3	Doc Name 03 System Power	Ver. X1
		Date Tuesday, January 27, 2015	Sheet 3 of 17	

# AUDIO

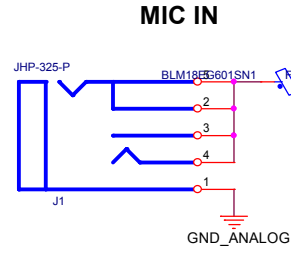
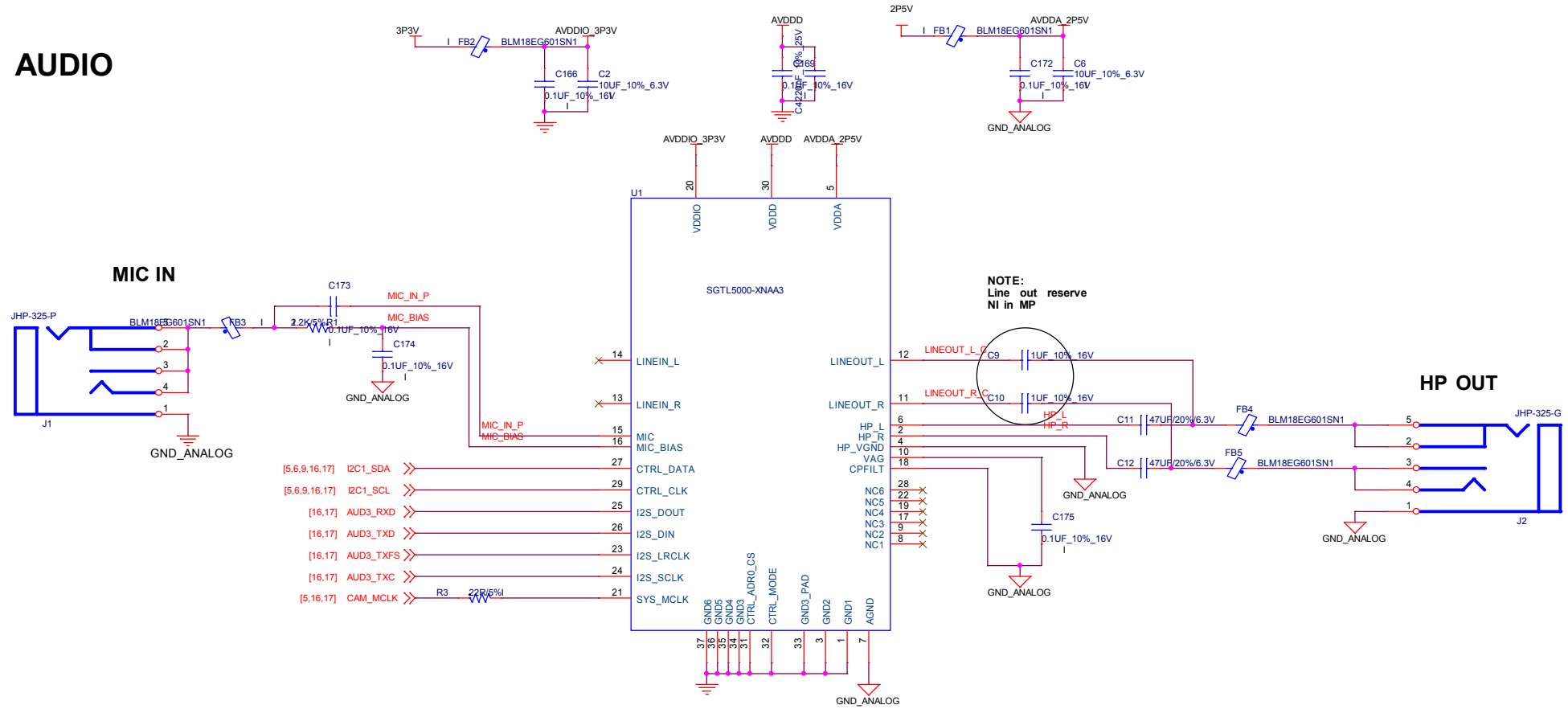

**NOTE:**  
Line out reserve  
NI in MP

## HP OUT

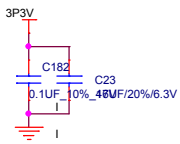
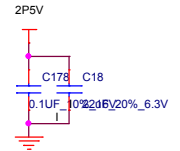
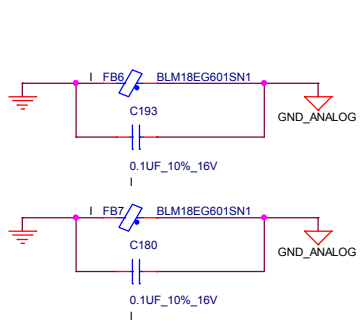

Design	<design>	Embest Tech Co. LTD		
Review	<review>			
Authorize	<authorize>	Title	SBC9000	
Standardize	<standardize>	Size	Doc Name	Ver.
		A3	04 Audio	V1.0
		Date	Tuesday, January 27, 2015	Sheet 4 of 17

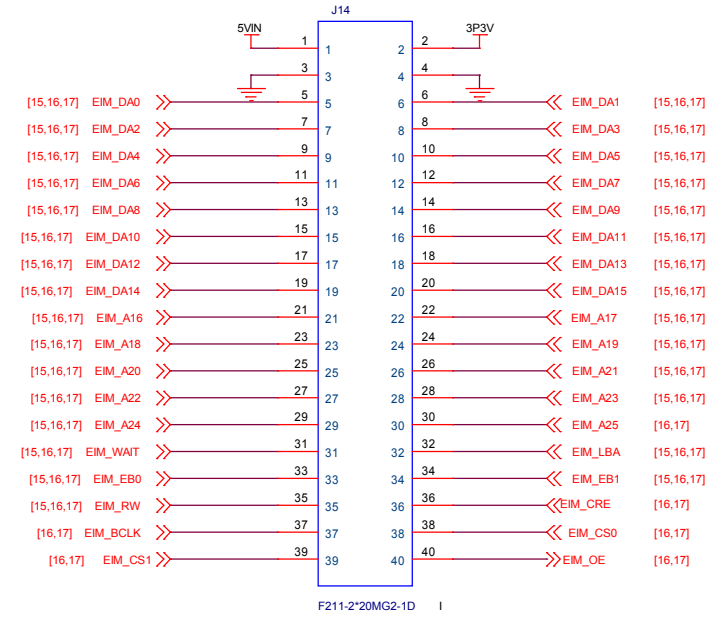
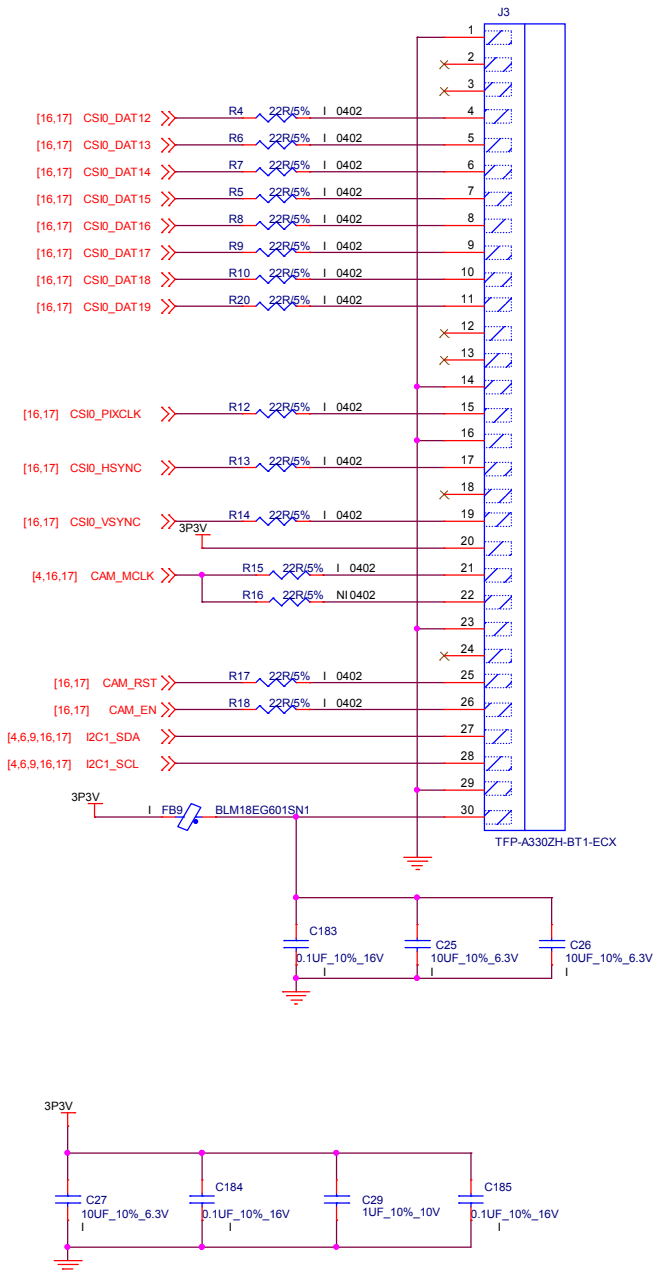

GPIO

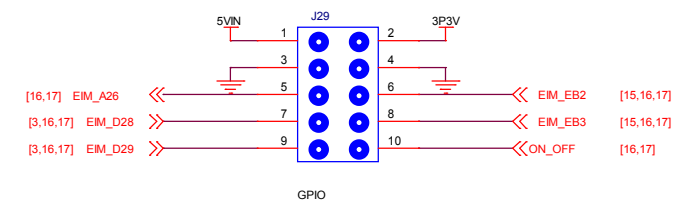

Design	<design>	<b>Embest Tech Co. LTD</b>		
Review	<review>			
Authorize	<authorize>	Title SBC9000		Ver.
Standardize	<standardize>	Size A3	Doc Name 05 Camera & EIM & GPIO	X1
		Date Tuesday, January 27, 2015	Sheet 5 of 17	

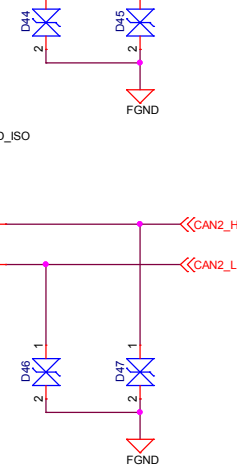
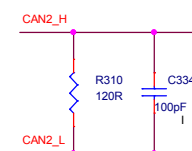
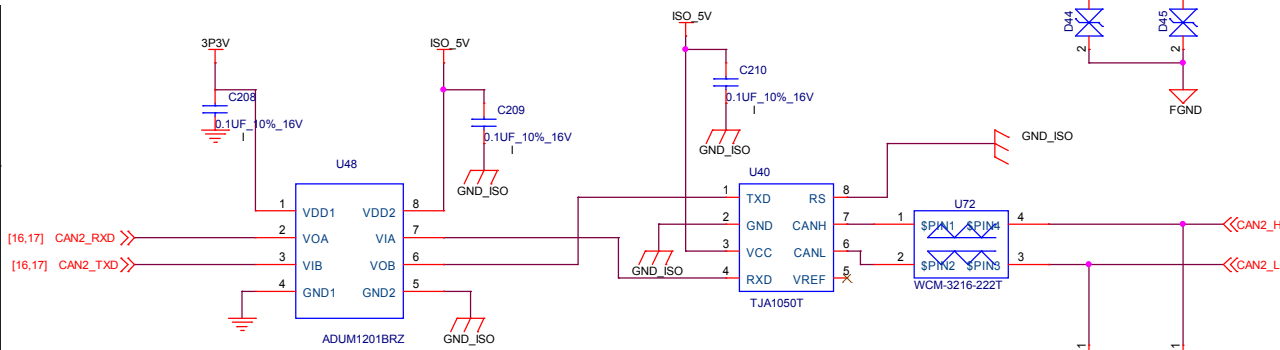
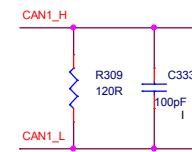
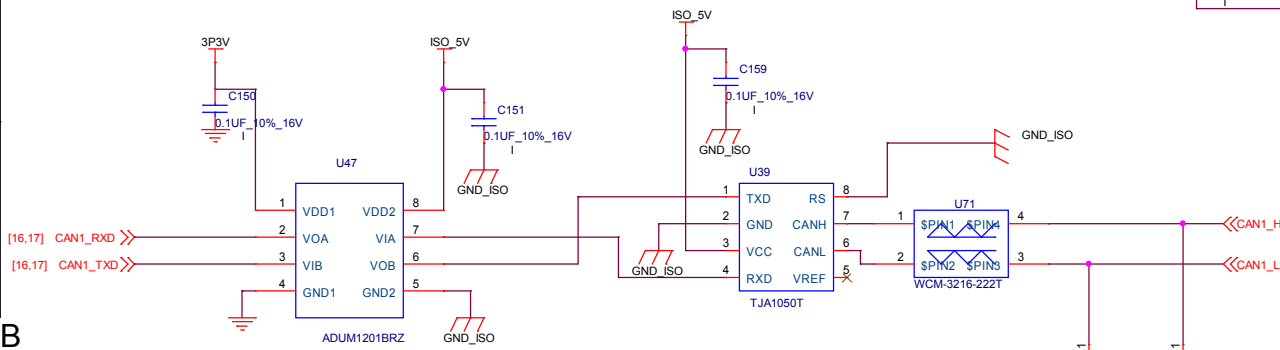
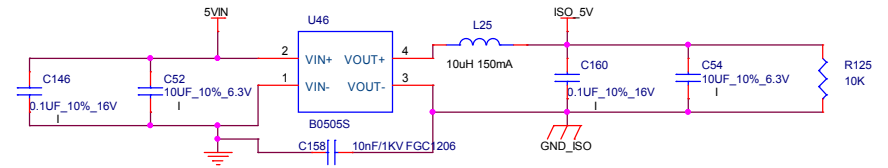
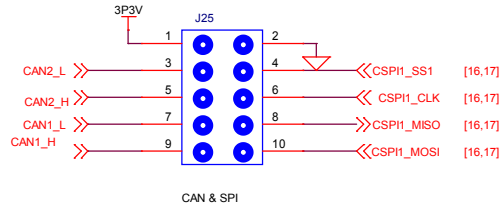
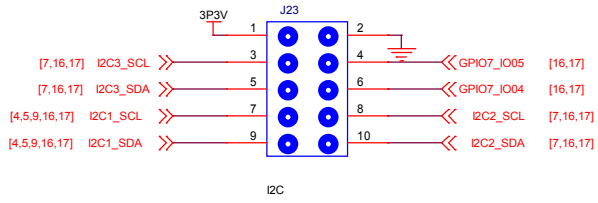

Design	<design>	Embest Tech Co. LTD		
Review	<review>			
Authorize	<authorize>	Title SBC9000		
Standardize	<standardize>	Size A3	Doc Name 06 CAN & I2C & SPI	Ver. X1
		Date Tuesday, January 27, 2015	Sheet 6 of 17	

# HDMI

Layout: HDMI 100 ohm differential pairs

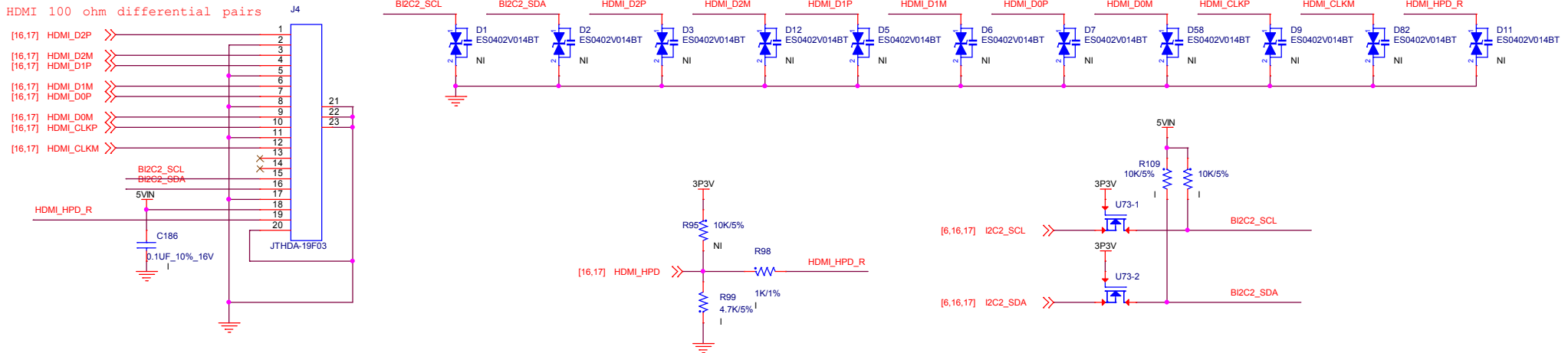

# LVDS

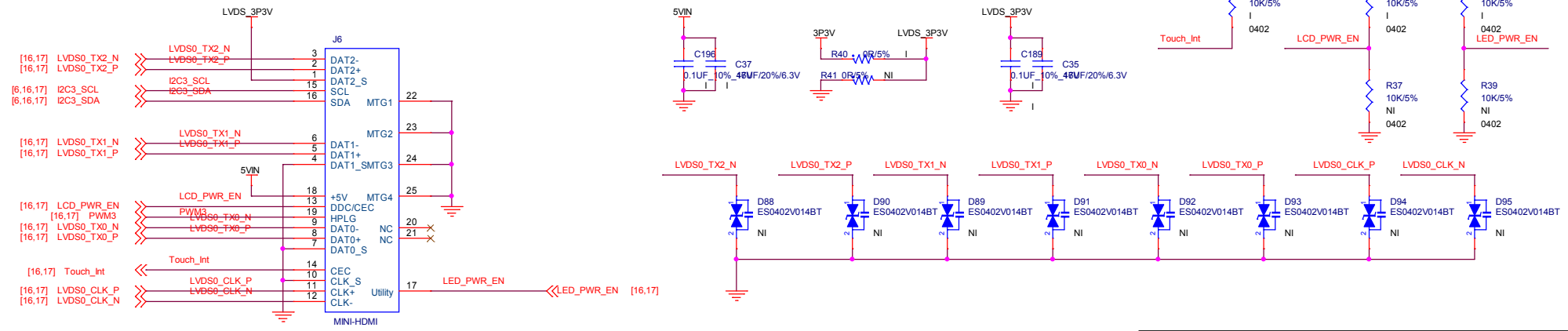

Design	<design>	<b>Embest Tech Co. LTD</b>		
Review	<review>			
Authorize	<authorize>	Title SBC9000		
Standardize	<standardize>	Size	Doc Name	Ver.
		A3	07 HDMI & LVDS	X1
		Date	Tuesday, January 27, 2015	Sheet 7 of 17

# Mini PCIe Card

4

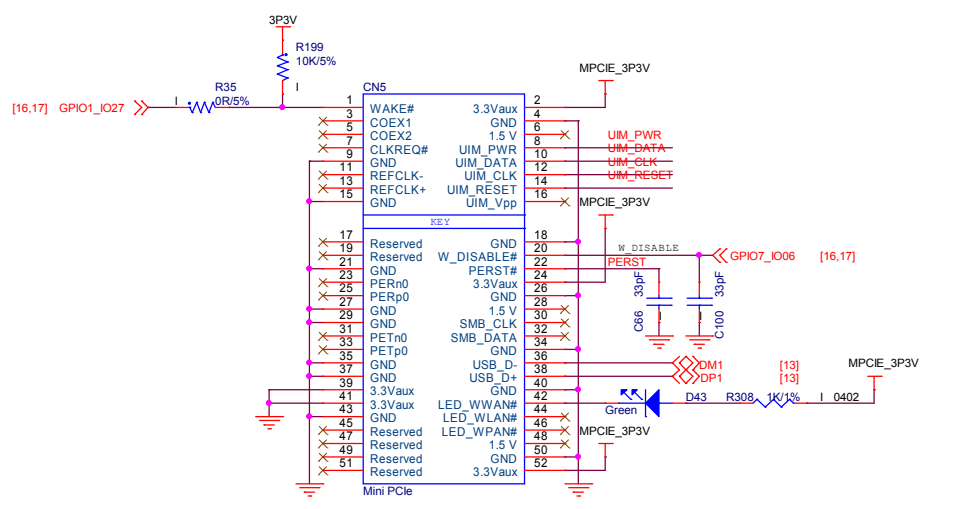

# Power & Control

2

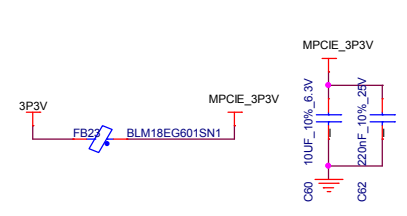

1

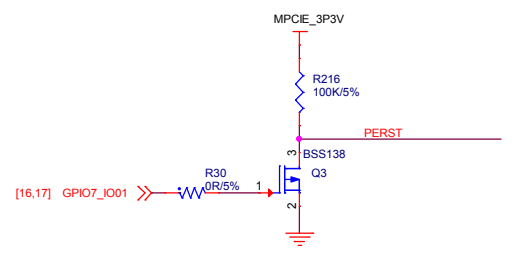

# SIM Card

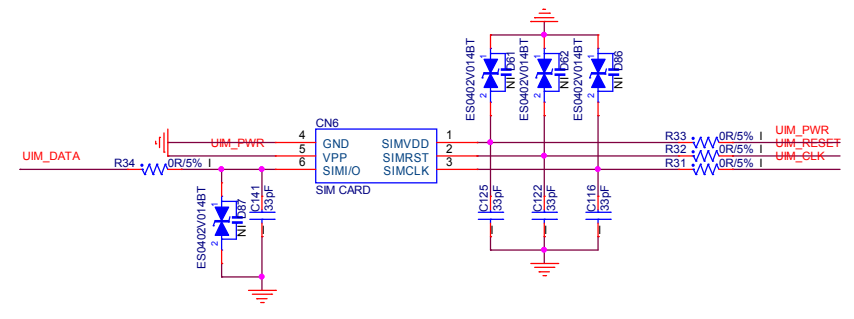

Design	<design>	<b>Embest Tech Co. LTD</b>		
Review	<review>			
Authorize	<authorize>	Title SBC9000		
Standardize	<standardize>	Size A3	Doc Name 08 Mini PCIe	Ver. X1
		Date Tuesday, January 27, 2015	Sheet 8 of 17	



# OTG

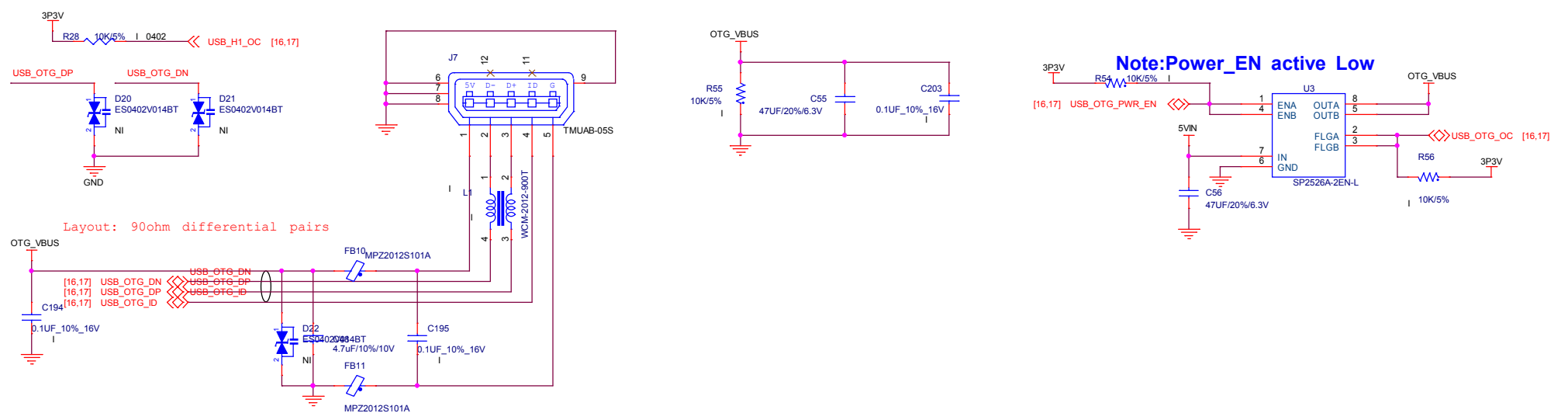

# PCIe

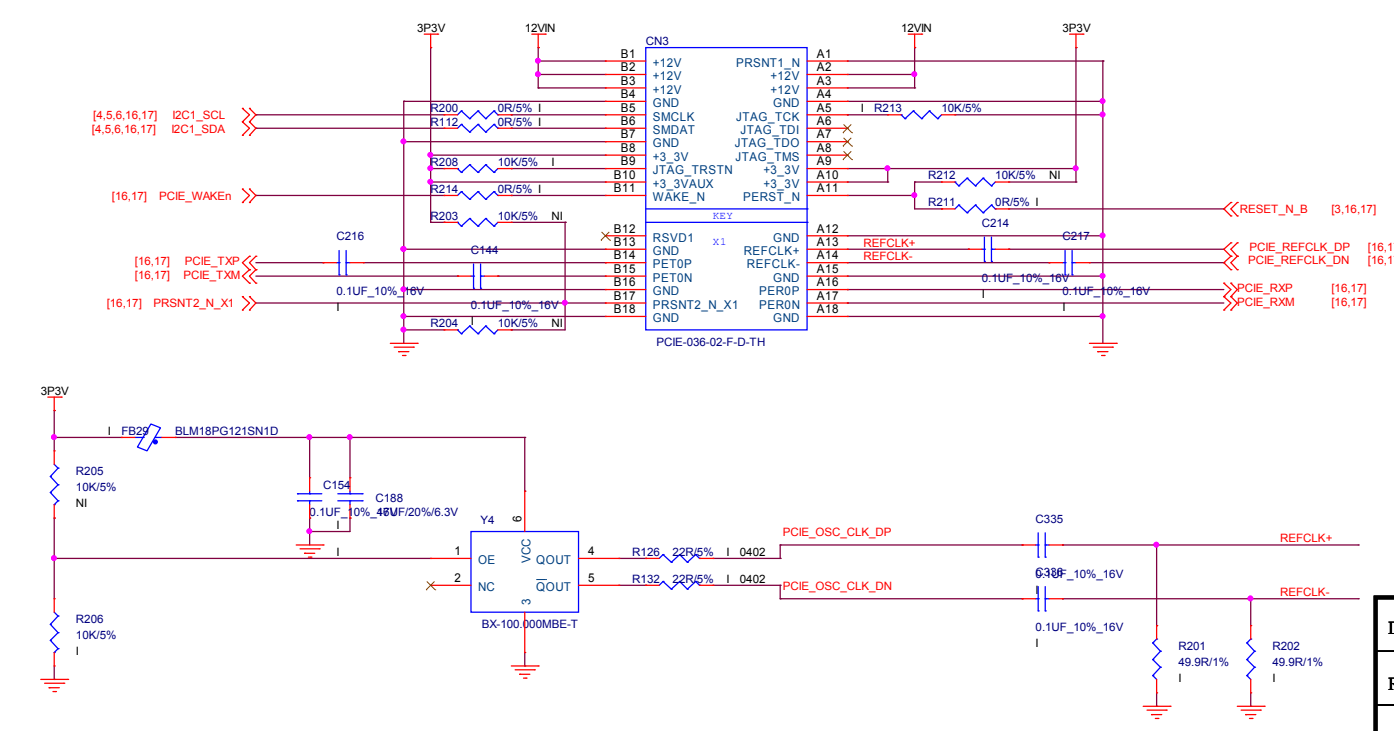

Design	<design>	<b>Embest Tech Co. LTD</b>		
Review	<review>			
Authorize	<authorize>	Title SBC9000		
Standardize	<standardize>	Size	Doc Name	Ver.
		A3	09 OTG & PCIe	X1
		Date	Tuesday, January 27, 2015	Sheet 9 of 17

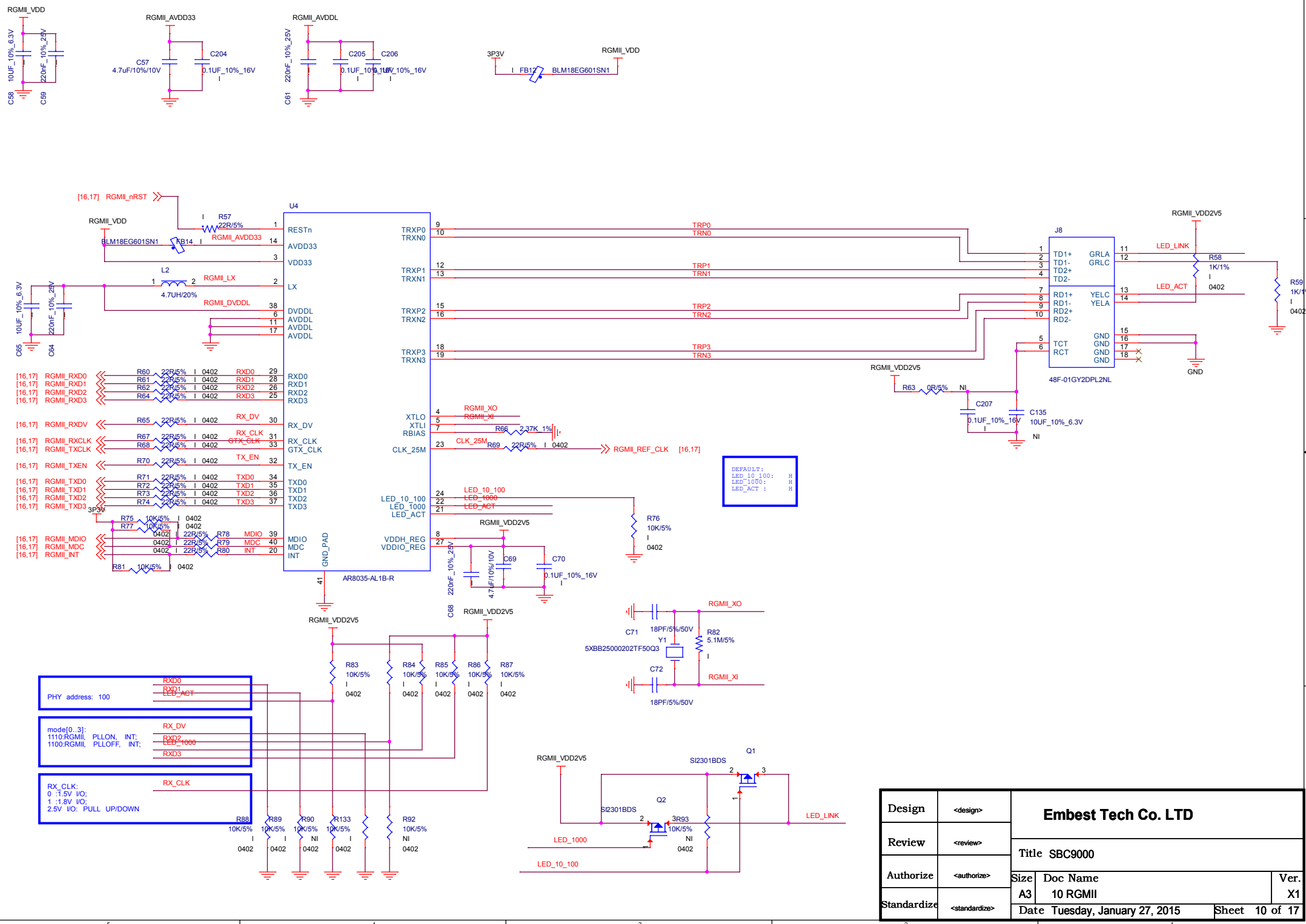

PHY address: 100

mode[0..3]:  
1110:RGMI, PLLON, INT;  
1100:RGMI, PLLOFF, INT;

RX\_CLK:  
0 :1.5V I/O;  
1 :1.8V I/O;  
2.5V I/O: PULL UP/DOWN

DEFAULT:  
LED\_10\_100: H  
LED\_1000: H  
LED\_ACT : H

Design	<design>	<b>Embest Tech Co. LTD</b>		
Review	<review>			
Authorize	<authorize>	Title SBC9000		
Standardize	<standardize>	Size	Doc Name	Ver.
		A3	10 RGMI	X1
		Date	Tuesday, January 27, 2015	Sheet 10 of 17

Power

JMB321

D

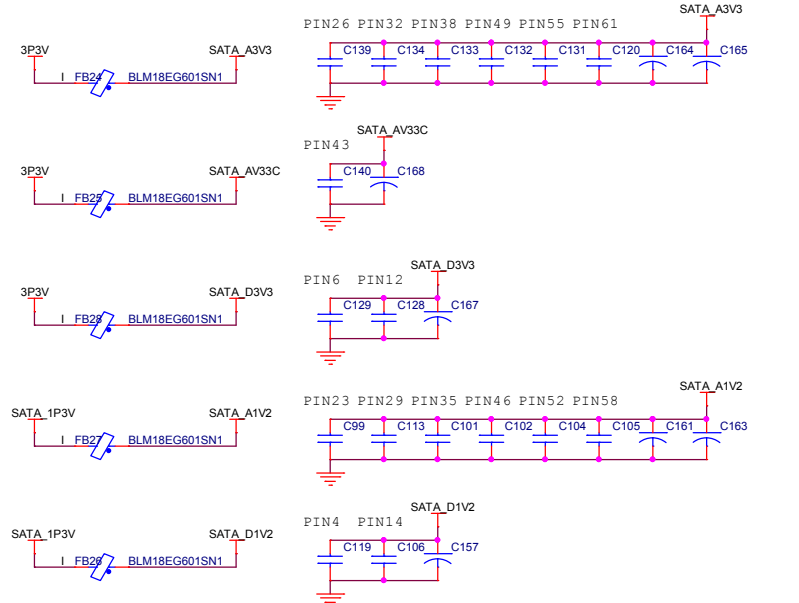
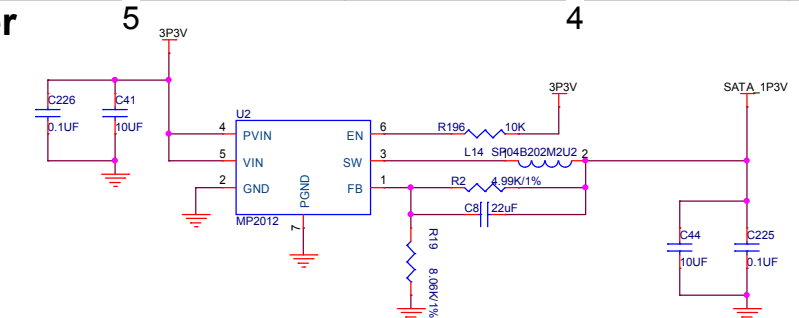

Control

Connector

A

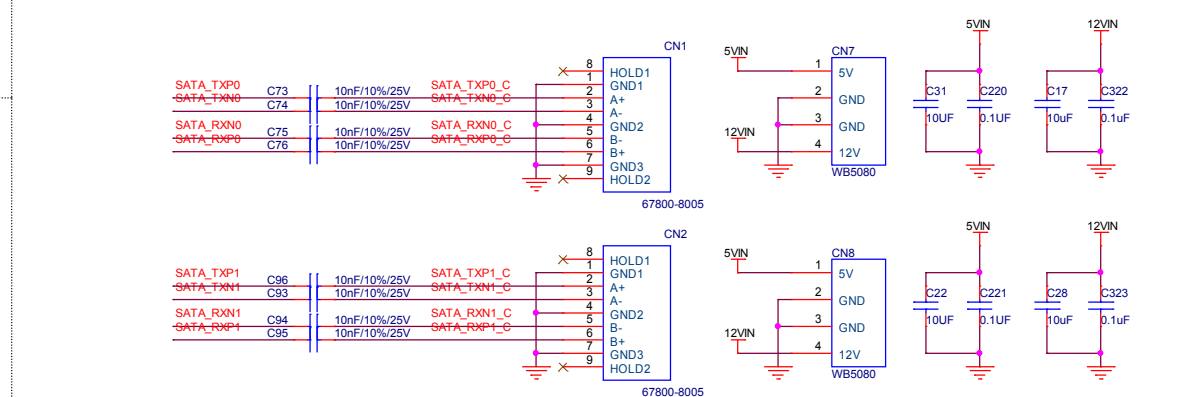
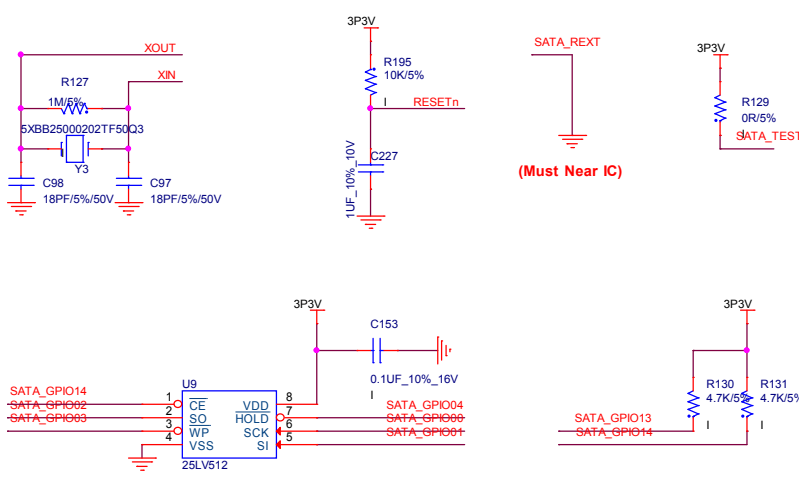

Design	<design>	Embest Tech Co. LTD		
Review	<review>			
Authorize	<authorize>	Title	SBC9000	
Standardize	<standardize>	Size	Doc Name	Ver.
		A3	11 SATA	X1
		Date	Tuesday, January 27, 2015	Sheet 11 of 17

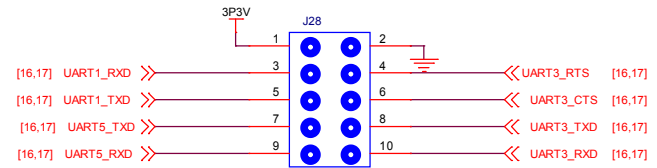
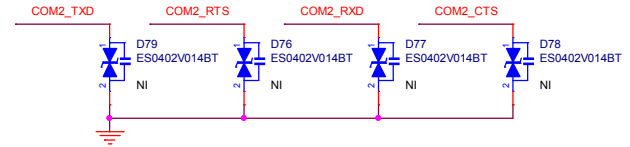
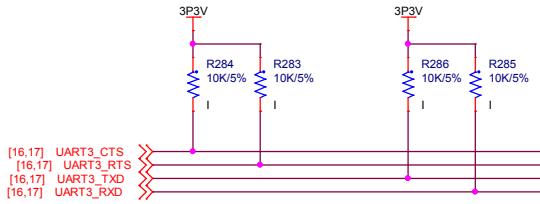
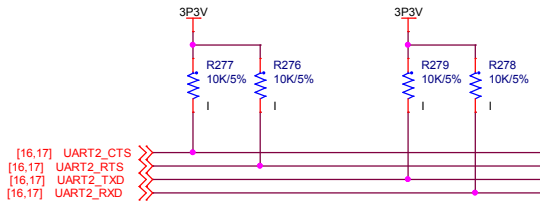
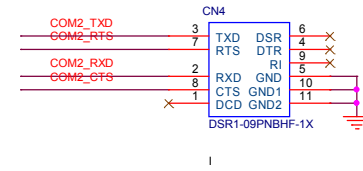
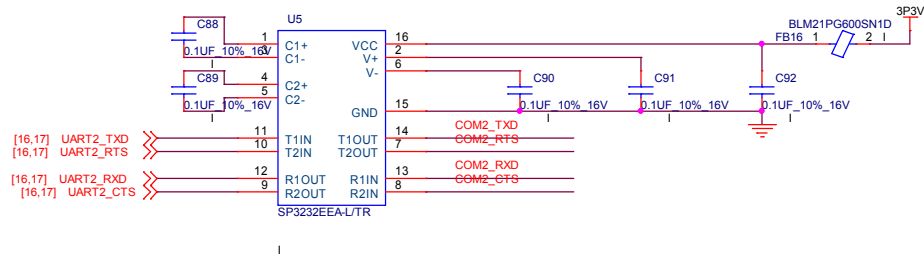

Design	<design>	<b>Embest Tech Co. LTD</b>		
Review	<review>			
Authorize	<authorize>	Size	Doc Name	Ver.
Standardize	<standardize>	A3	12 UART	X1
		Date	Tuesday, January 27, 2015	Sheet 12 of 17

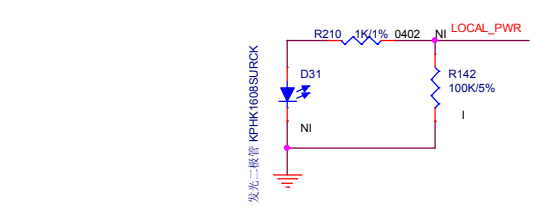
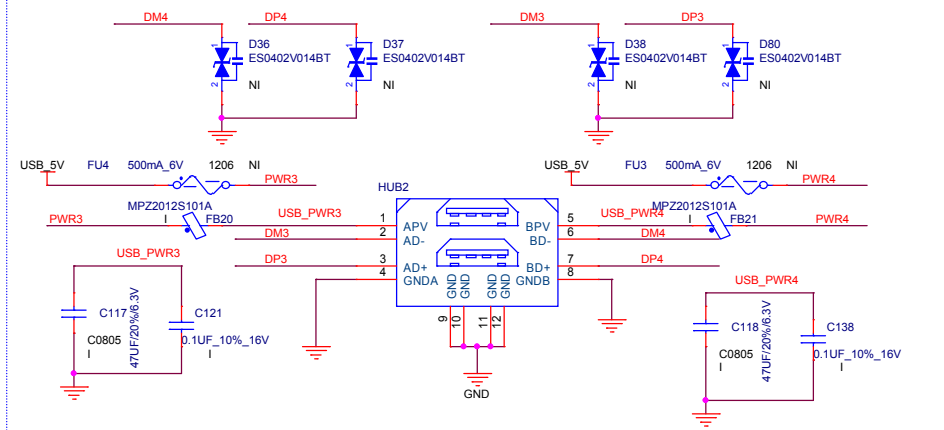
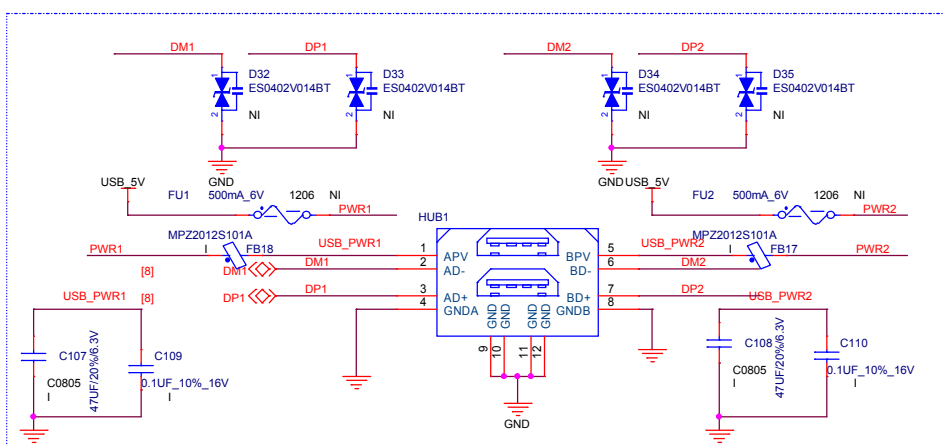
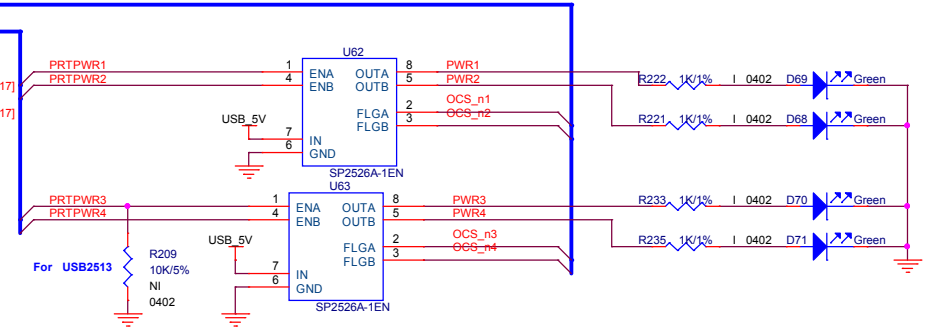
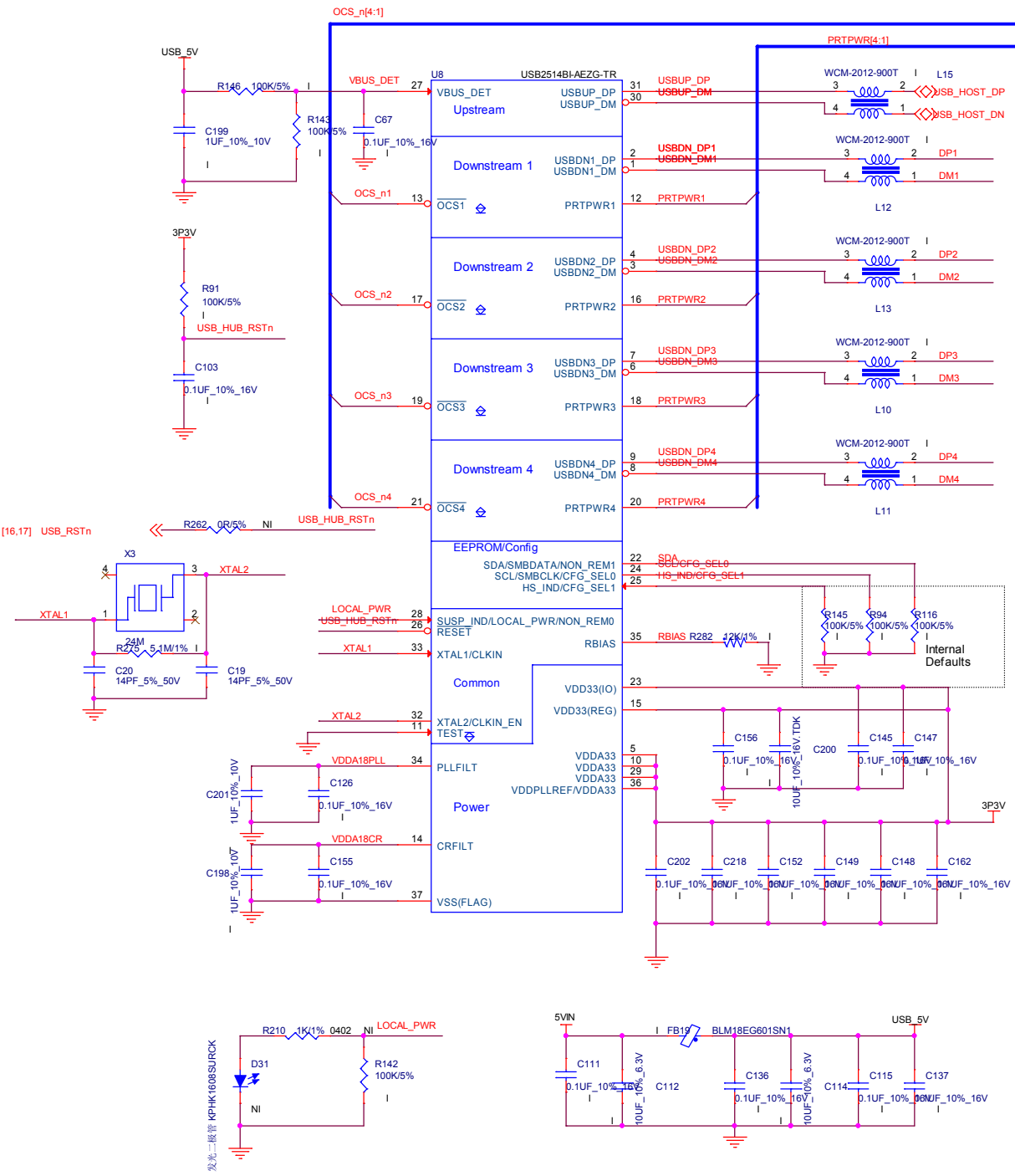

Design	<design>	<b>Embest Tech Co. LTD</b>		
Review	<review>			
Authorize	<authorize>	Title SBC9000		Ver. X1
Standardize	<standardize>	Size A3	Doc Name 13 USB	
		Date Tuesday, January 27, 2015	Sheet 13 of 17	

5 4 3 2 1

D

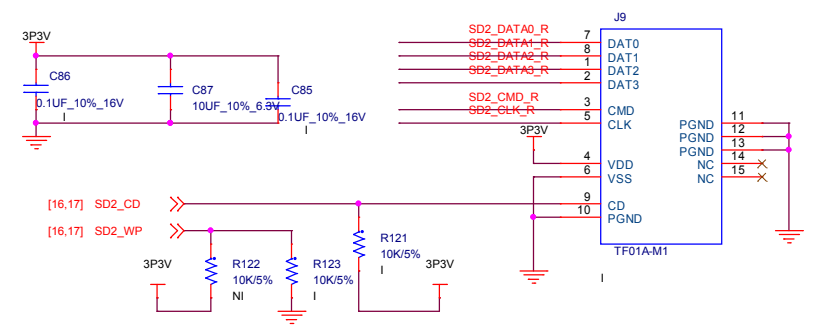
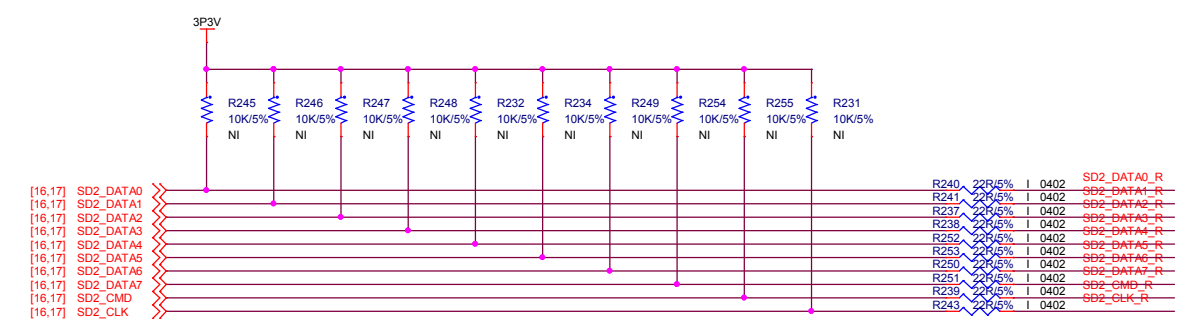

C

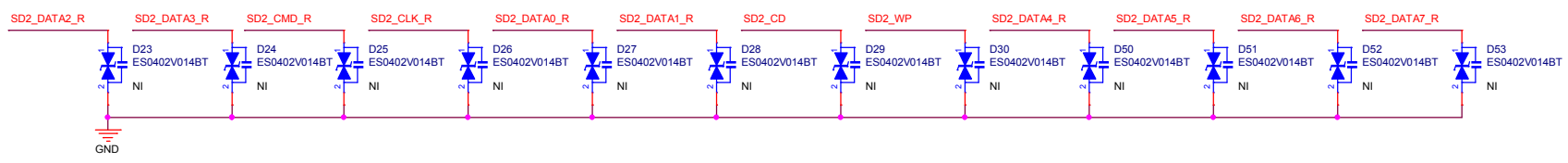

B

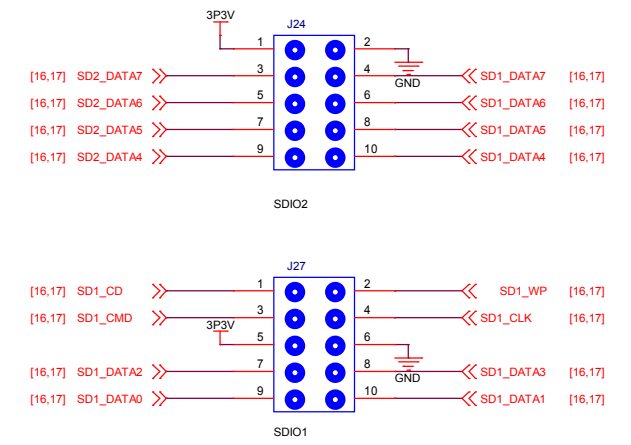
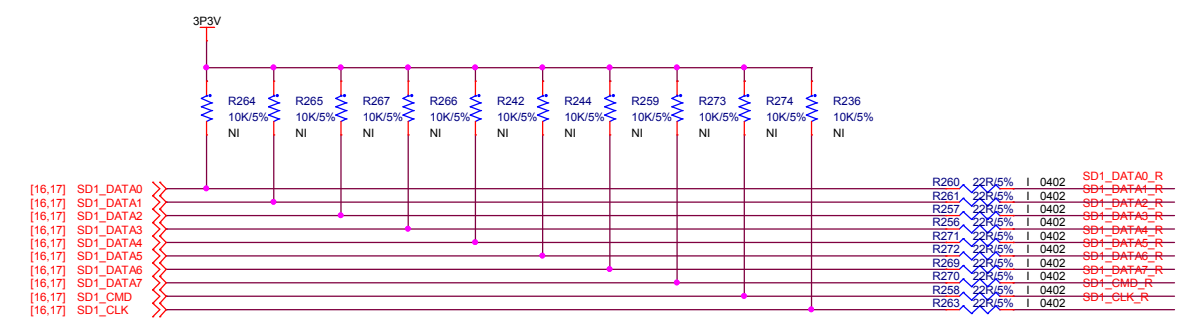

A

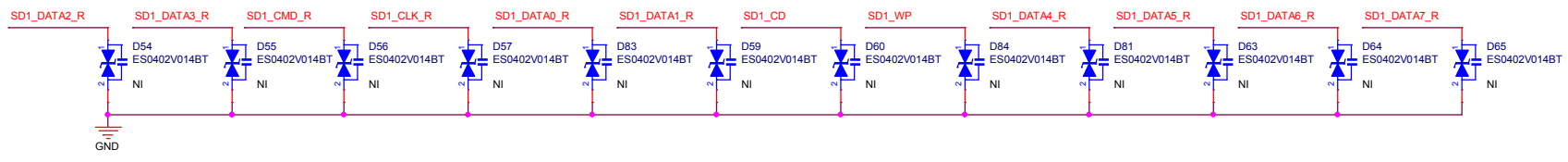

Design	<design>	Embest Tech Co. LTD		
Review	<review>			
Authorize	<authorize>	Size	Doc Name	Ver.
Standardize	<standardize>	A3	14 SDIO	X1
		Date	Tuesday, January 27, 2015	Sheet 14 of 17

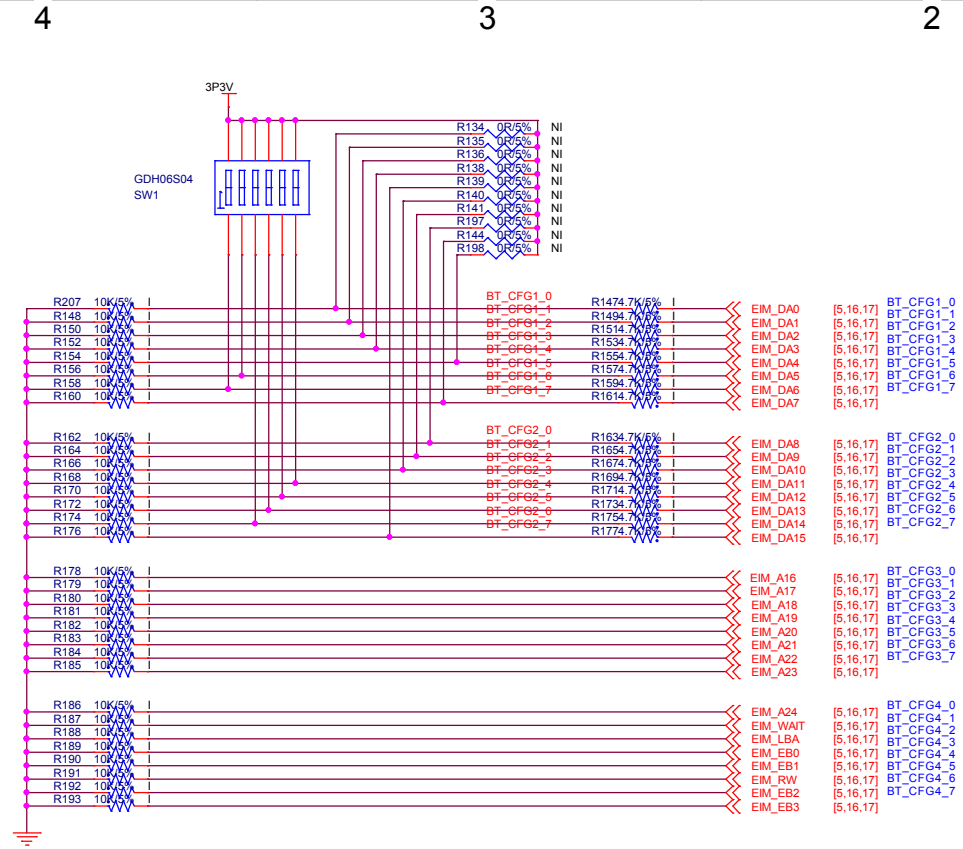

**Boot Select Table**

BT_CFG1_7	BT_CFG1_6	BT_CFG1_5	BT_CFG1_4	BT_CFG2_6	BT_CFG2_5	BT_CFG2_4	BT_CFG2_3
011X = MMC / eMMC Boot				X0 = 1 - bit X1 = 4 - bit 10 = 8 - bit	00 = SD1 Boot 01 = SD2 Boot 11 = SD4 Boot		
010X = SD / eSD Boot				X0 = 1 - bit X1 = 4 - bit	00 = SD1 Boot 01 = SD2 Boot 11 = SD4 Boot		
0010 = SATA Boot				X	X	X	0

Design	<design>	<b>Embest Tech Co. LTD</b>		
Review	<review>	Title SBC9000		
Authorize	<authorize>	Size	Doc Name	Ver.
Standardize	<standardize>	A3	15 Boot	X1
Date			Tuesday, January 27, 2015	Sheet 15 of 17

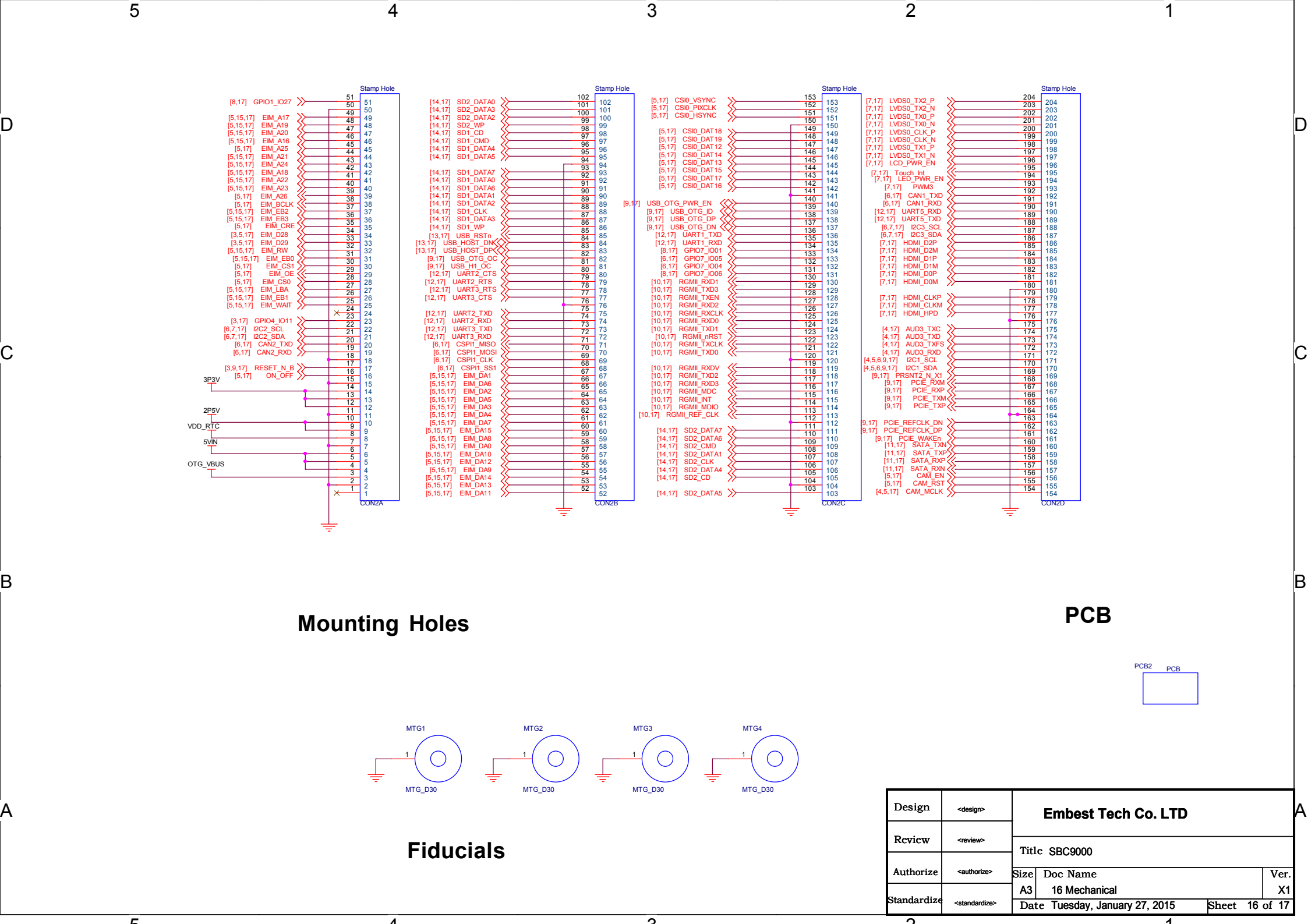

Signal	Pin	Signal	Pin	Signal	Pin	Signal	Pin
[8,17] GPIO1_IO27	51	[14,17] SD2_DATA0	102	[5,17] CSIO_VSYNC	153	[7,17] LVDS0_TX2_P	204
[5,15,17] EIM_A17	50	[14,17] SD2_DATA3	101	[5,17] CSIO_PIXCLK	152	[7,17] LVDS0_TX2_N	203
[5,15,17] EIM_A19	49	[14,17] SD2_DATA2	100	[5,17] CSIO_HS_SYNC	151	[7,17] LVDS0_TX0_P	202
[5,15,17] EIM_A20	48	[14,17] SD2_WP	99	[5,17] CSIO_DAT18	149	[7,17] LVDS0_TX0_N	201
[5,15,17] EIM_A16	47	[14,17] SD1_CD	98	[5,17] CSIO_DAT19	148	[7,17] LVDS0_CLK_P	199
[5,15,17] EIM_A25	46	[14,17] SD1_CMD	97	[5,17] CSIO_DAT12	147	[7,17] LVDS0_CLK_N	198
[5,17] EIM_A21	45	[14,17] SD1_DATA1	96	[5,17] CSIO_DAT14	146	[7,17] LVDS0_TX1_P	197
[5,15,17] EIM_A24	44	[14,17] SD1_DATA4	95	[5,17] CSIO_DAT13	145	[7,17] LVDS0_TX1_N	196
[5,15,17] EIM_A18	43	[14,17] SD1_DATA5	94	[5,17] CSIO_DAT15	144	[7,17] LCD_PWR_EN	195
[5,15,17] EIM_A22	42	[14,17] SD1_DATA7	93	[5,17] CSIO_DAT17	143	[7,17] Touch_Int	194
[5,15,17] EIM_A23	41	[14,17] SD1_DATA0	92	[5,17] CSIO_DAT16	142	[7,17] LED_PWR_EN	193
[5,15,17] EIM_A26	40	[14,17] SD1_DATA6	91	[9,17] USB_OTG_PWR_EN	141	[7,17] PWM3	192
[5,17] EIM_BCLK	39	[14,17] SD1_DATA1	90	[9,17] USB_OTG_ID	140	[6,17] CAN1_TXD	191
[5,15,17] EIM_EB2	38	[14,17] SD1_DATA2	89	[9,17] USB_OTG_DP	139	[6,17] CAN1_RXD	190
[5,15,17] EIM_EB3	37	[14,17] SD1_CLK	88	[9,17] USB_OTG_DP	138	[12,17] UART5_RXD	189
[5,17] EIM_CRE	36	[14,17] SD1_DATA3	87	[9,17] USB_OTG_DN	137	[12,17] UART5_TXD	188
[3,5,17] EIM_D28	35	[14,17] SD1_WP	86	[10,17] RGMII_RXD1	136	[6,7,17] I2C3_SCL	187
[3,5,17] EIM_D29	34	[13,17] USB_RSTn	85	[12,17] UART1_TXD	135	[6,7,17] I2C3_SDA	186
[5,15,17] EIM_D29	33	[13,17] USB_HOST_DNK	84	[12,17] UART1_RXD	134	[7,17] HDMI_D2P	185
[5,15,17] EIM_EB0	32	[13,17] USB_HOST_DPK	83	[8,17] GPIO7_I001	133	[7,17] HDMI_D2M	184
[5,17] EIM_CS1	31	[9,17] USB_OTG_OC	82	[6,17] GPIO7_I005	132	[7,17] HDMI_D1P	183
[5,17] EIM_OE	30	[9,17] USB_H1_OC	81	[6,17] GPIO7_I006	131	[7,17] HDMI_D1M	182
[5,17] EIM_CS0	29	[12,17] UART2_CTS	80	[8,17] GPIO7_I004	130	[7,17] HDMI_D0P	181
[5,15,17] EIM_LBA	28	[12,17] UART2_RTS	79	[10,17] RGMII_RXD1	129	[7,17] HDMI_D0M	180
[5,15,17] EIM_EB1	27	[12,17] UART3_RTS	78	[10,17] RGMII_TXD3	128	[7,17] HDMI_CLKP	179
[5,15,17] EIM_WAIT	26	[12,17] UART3_CTS	77	[10,17] RGMII_TXEN	127	[7,17] HDMI_CLKM	178
[3,17] GPIO4_IO11	25	[12,17] UART2_TXD	76	[10,17] RGMII_RXD3	126	[7,17] HDMI_HPD	177
[6,7,17] I2C2_SCL	24	[12,17] UART2_RXD	75	[10,17] RGMII_RXCLK	125	[4,7] AUD3_TXC	176
[6,7,17] I2C2_SDA	23	[12,17] UART3_TXD	74	[10,17] RGMII_RXD0	124	[4,7] AUD3_TXD	175
[6,7,17] CAN2_TXD	22	[12,17] UART3_RXD	73	[10,17] RGMII_nRST	123	[4,7] AUD3_TXFS	174
[6,7,17] CAN2_RXD	21	[12,17] UART3_RXD	72	[10,17] RGMII_TXCLK	122	[4,7] AUD3_RXD	173
[3,9,17] RESET_N_B	20	[6,17] CSPI1_MISO	71	[10,17] RGMII_TXD0	121	[4,5,6,9,17] I2C1_SCL	172
[5,17] ON_OFF	19	[6,17] CSPI1_MOSI	70	[10,17] RGMII_RXD0	120	[4,5,6,9,17] I2C1_SDA	171
3P3V	18	[6,17] CSPI1_CLK	69	[10,17] RGMII_TXD2	119	[9,17] PRSNT2_N_X1	170
2P5V	17	[5,15,17] EIM_DA1	68	[10,17] RGMII_TXD3	118	[9,17] PCIE_RXM	169
VDD_RTC	16	[5,15,17] EIM_DA6	67	[10,17] RGMII_MDC	117	[9,17] PCIE_RXP	168
5VIN	15	[5,15,17] EIM_DA5	66	[10,17] RGMII_INT	116	[9,17] PCIE_TXM	167
OTG_VBUS	14	[5,15,17] EIM_DA4	65	[10,17] RGMII_MDIO	115	[9,17] PCIE_TXP	166
	13	[5,15,17] EIM_DA7	64	[10,17] RGMII_REF_CLK	114		165
	12	[5,15,17] EIM_DA15	63		113		164
	11	[5,15,17] EIM_DA8	62		112		163
	10	[5,15,17] EIM_DA10	61		111		162
	9	[5,15,17] EIM_DA12	60		110		161
	8	[5,15,17] EIM_DA9	59		109		160
	7	[5,15,17] EIM_DA11	58		108		159
	6	[5,15,17] EIM_DA13	57		107		158
	5	[5,15,17] EIM_DA14	56		106		157
	4	[5,15,17] EIM_DA13	55		105		156
	3	[5,15,17] EIM_DA11	54		104		155
	2	[5,15,17] EIM_DA11	53		103		154
	1	[5,15,17] EIM_DA11	52		103		154

### Mounting Holes

### PCB

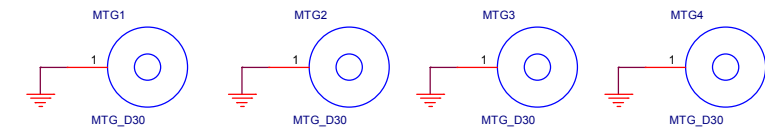

### Fiducials

Design	<design>	<b>Embest Tech Co. LTD</b>		
Review	<review>			
Authorize	<authorize>	Size	Doc Name	Ver.
Standardize	<standardize>	A3	16 Mechanical	X1
		Date	Tuesday, January 27, 2015	Sheet 16 of 17



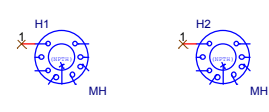
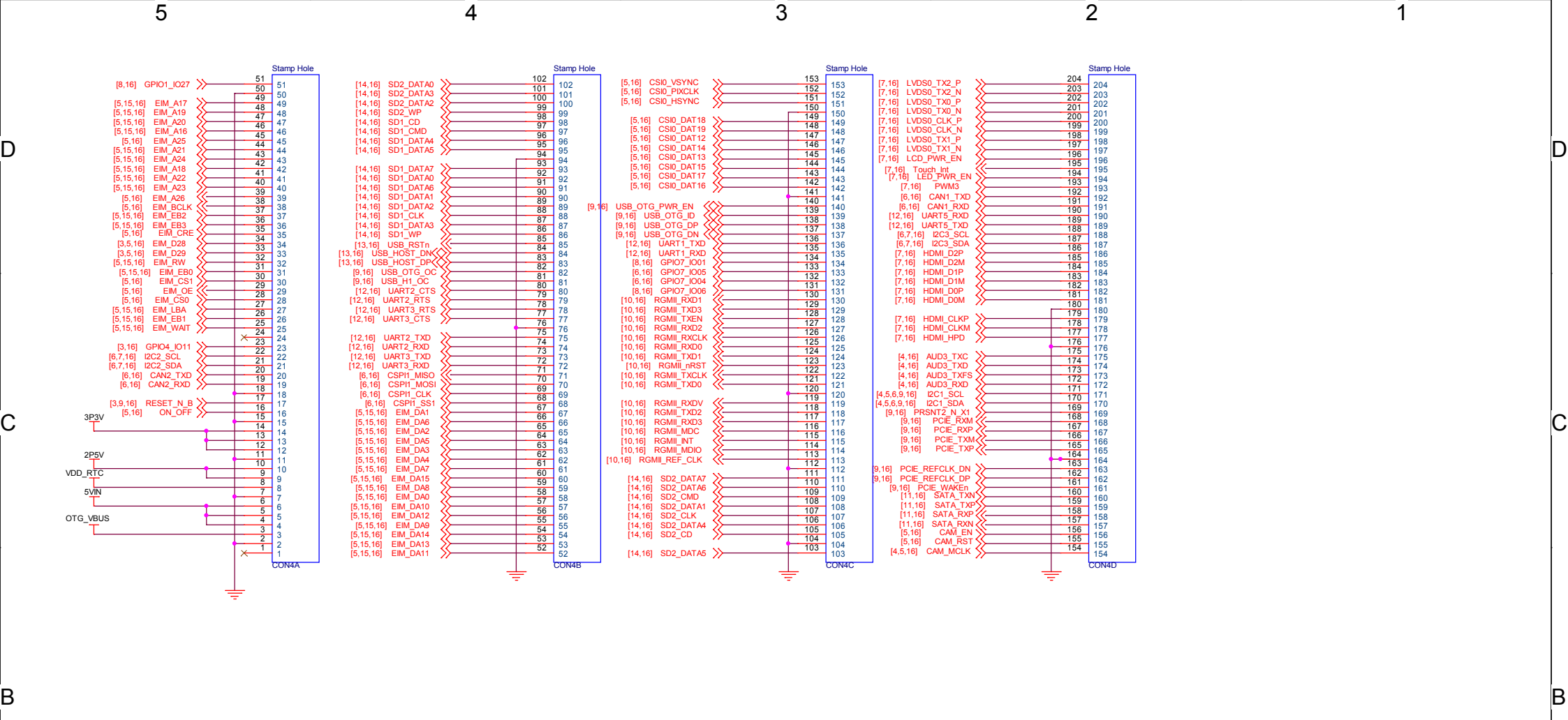

Design	<design>	<b>Embest Tech Co. LTD</b>		
Review	<review>			
Authorize	<authorize>	Size	Doc Name	Ver.
Standardize	<standardize>	A3	17 Package	X1
		Date	Tuesday, January 27, 2015	Sheet 17 of 17