

Design	<design>	Embest Tech Co. LTD		
Review	<review>	Title Mini9000		
Authorize	<authorize>	Size	Doc Name	Ver.
Standardize	<standardize>	A3	01 Conver Page	X1
		Date	Tuesday, January 27, 2015	Sheet 1 of 13

Schematic History

2014-07-25

- Delete D2
- Add GND test point
- Interchange net name of PWM3 and PWM4
- Add R104 and R105
- Change P/N of L1,L2,L3 and L4
- Modify package of R66

2014-09-22

- Add mechanical holes
- Add a power connector for test

Design	<design>	Embest Tech Co. LTD		
Review	<review>			
Authorize	<authorize>	Title Mini9000		
Standardize	<standardize>	Size	Doc Name	Ver.
		A3	02 Schematic History	X1
		Date	Tuesday, January 27, 2015	Sheet 2 of 13

VDD_SNV5

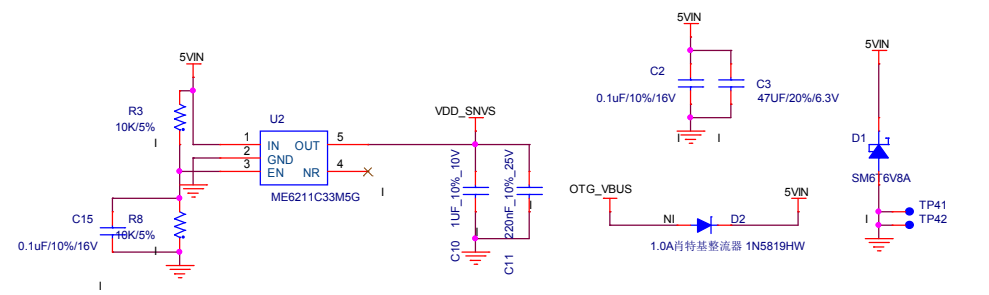

VCC_1P2V

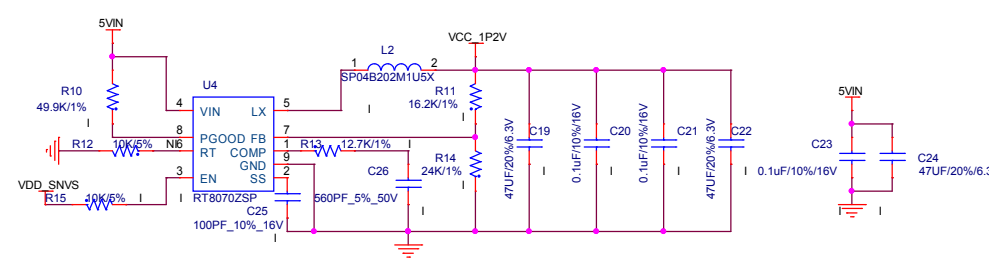

DDR_1_5V

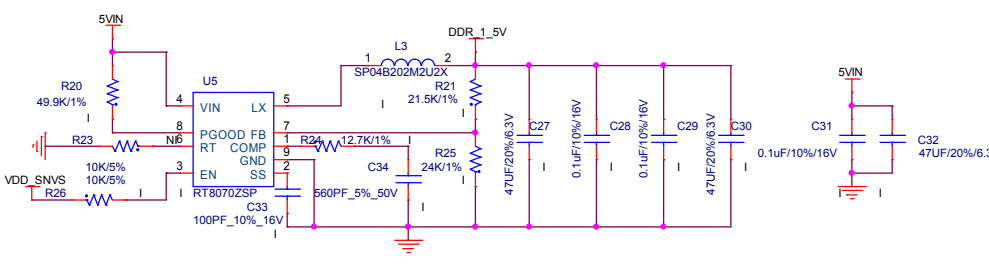

2P5V

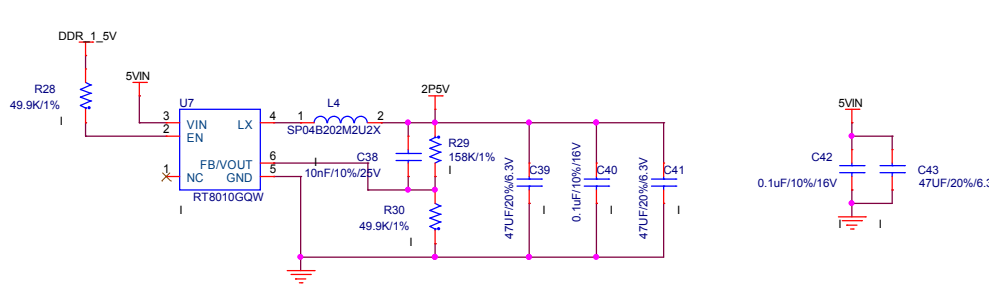

3P3V

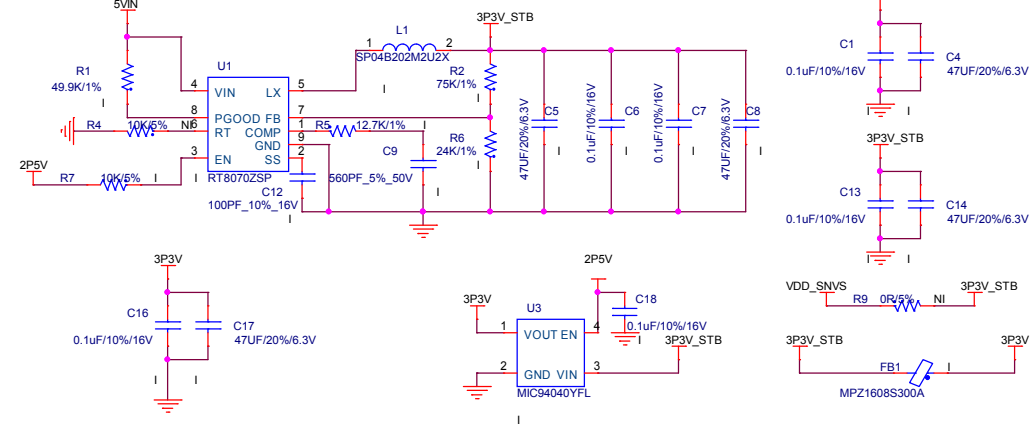

Boot

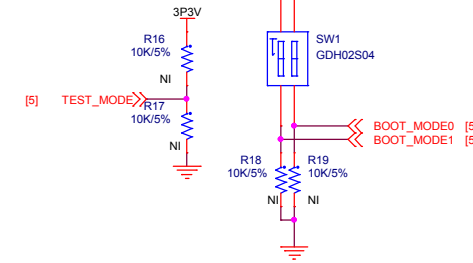

BOOT_MODE[1 : 0]	Boot Type
00	Boot From Fuses
01	Serial Downloader
10	Internal Boot
11	Reserved

HW Monitor

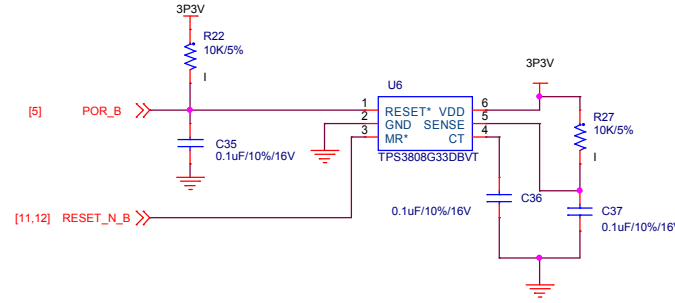

Design	<design>	Embest Tech Co. LTD		
Review	<review>			
Authorize	<authorize>	Title Mini9000		
Standardize	<standardize>	Size	Doc Name	Ver.
		A3	03 System Power	X1
		Date	Tuesday, January 27, 2015	Sheet 3 of 13

U8E
MCIMX6Q7CVT08AC

i.MX6Q - POWER

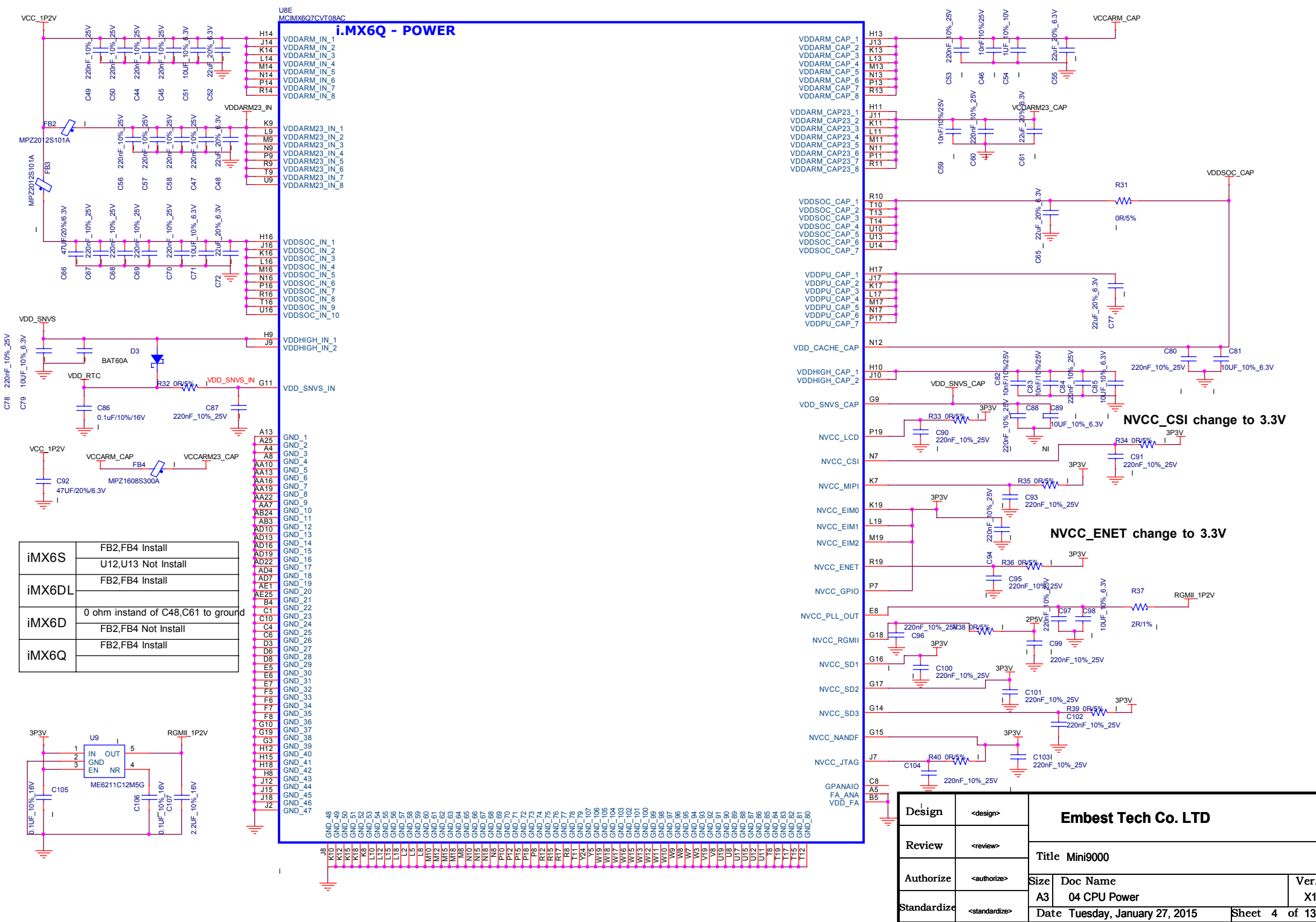

iMX6S	FB2,FB4 Install
	U12,U13 Not Install
iMX6DL	FB2,FB4 Install
iMX6D	0 ohm instand of C48,C61 to ground
	FB2,FB4 Not Install
iMX6Q	FB2,FB4 Install

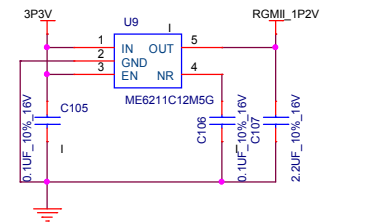

Design	<design>	Embest Tech Co. LTD		
Review	<review>			
Authorize	<authorize>	Title	Mini9000	
Standardize	<standardize>	Size	Doc Name	Ver.
		A3	04 CPU Power	X1
		Date	Tuesday, January 27, 2015	Sheet 4 of 13

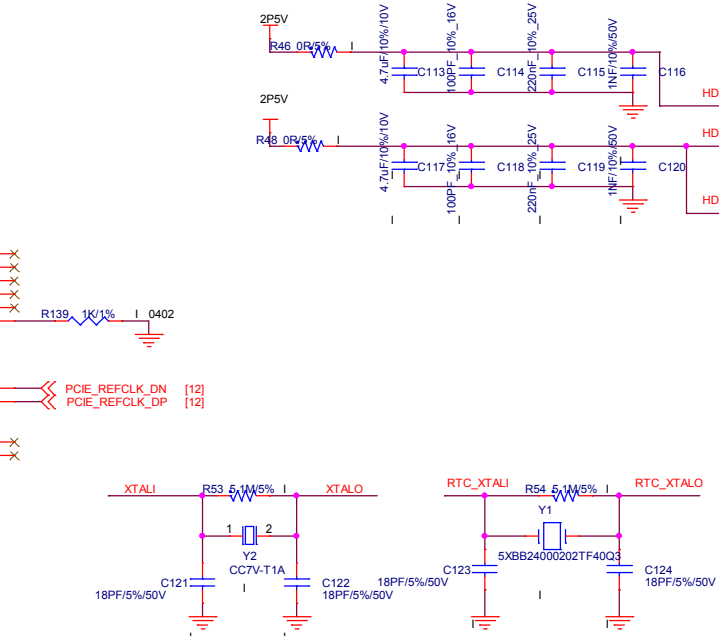
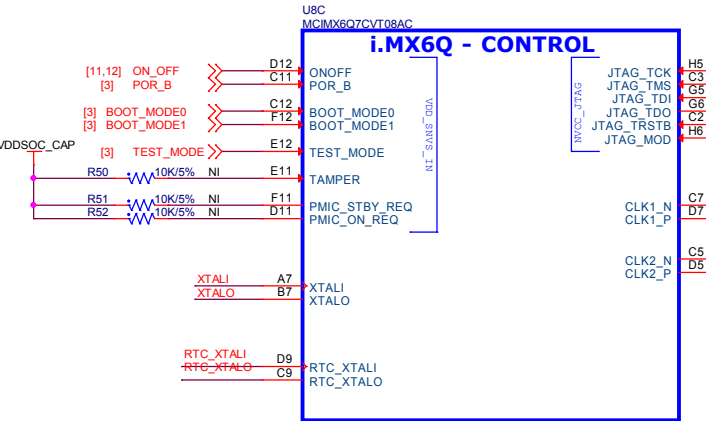
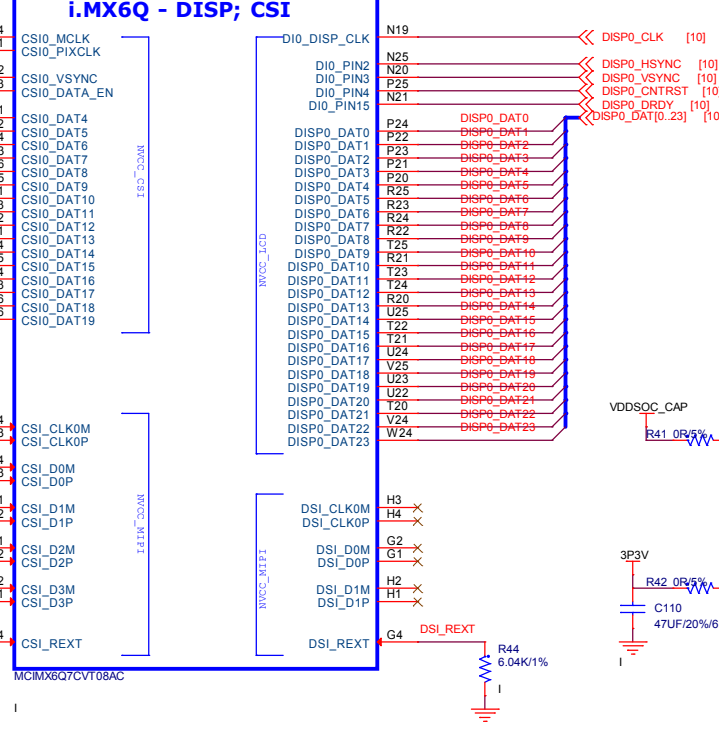
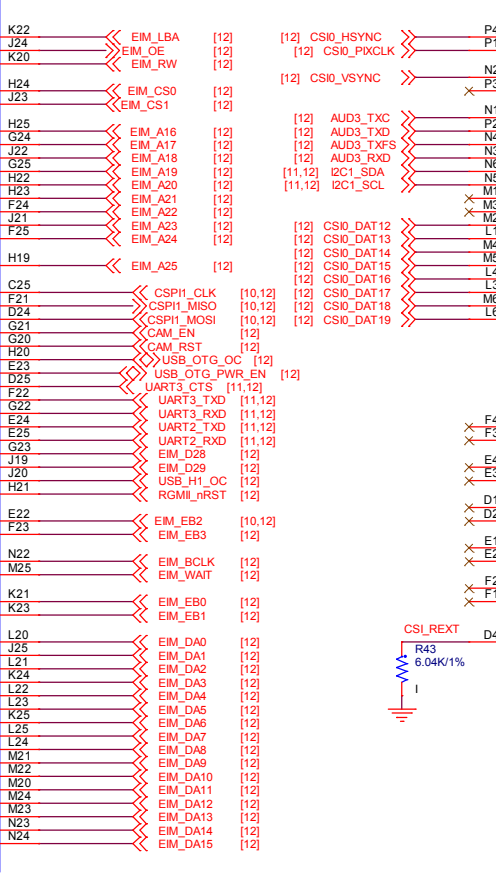
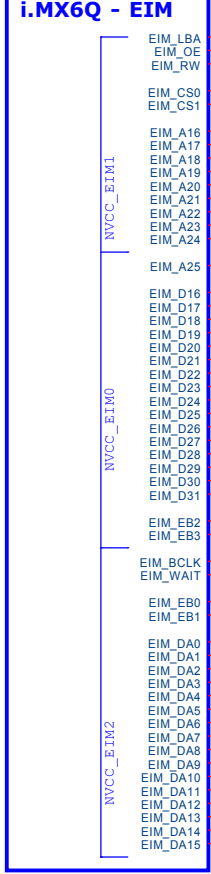

Design	<design>	Embest Tech Co. LTD		
Review	<review>			
Authorize	<authorize>	Title Mini9000		
Standardize	<standardize>	Size	Doc Name	Ver.
		A3	05 IMX6Q_SOC_A	X1
		Date	Tuesday, January 27, 2015	Sheet 5 of 13

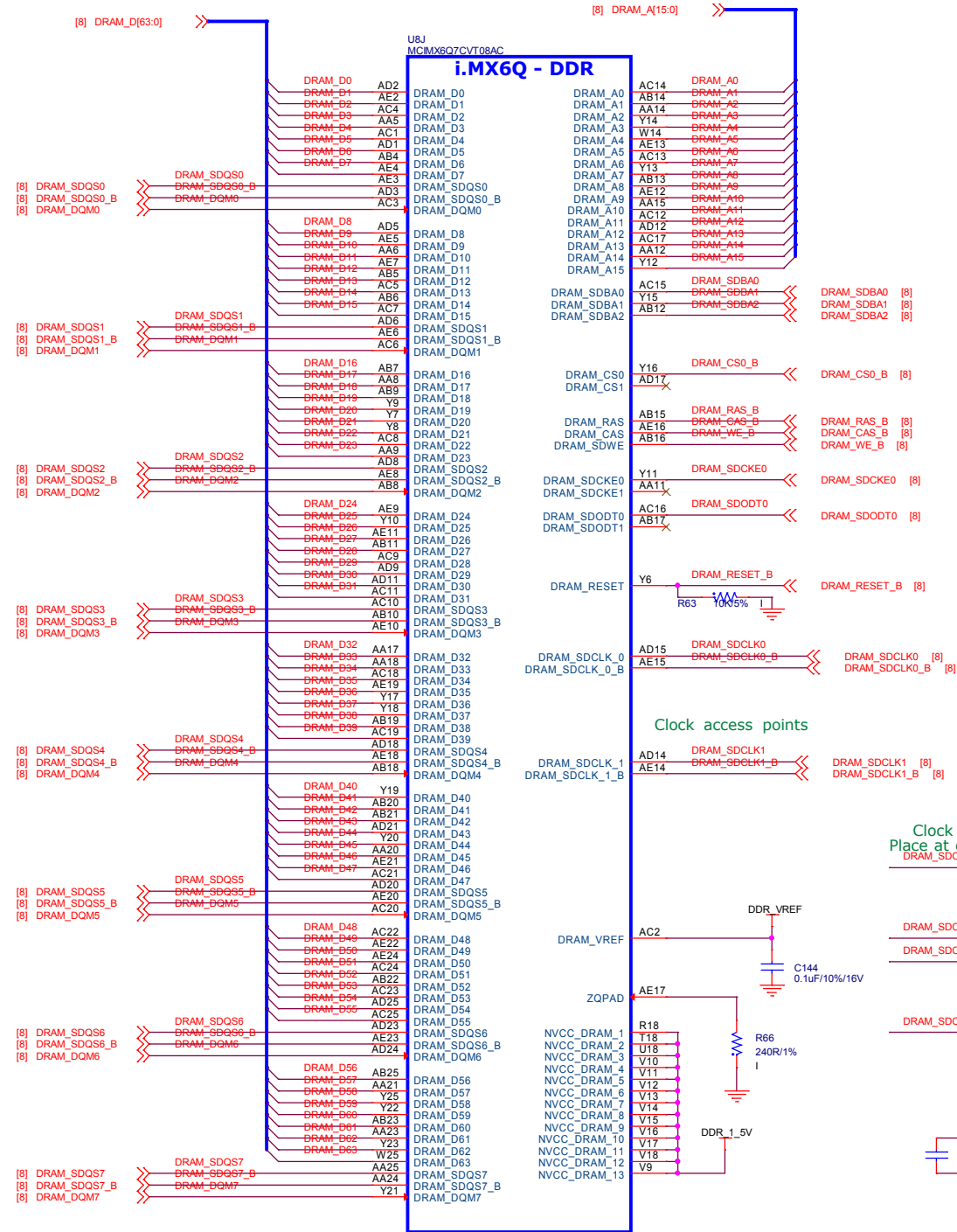

Clock terminators
Place at each DDR pair

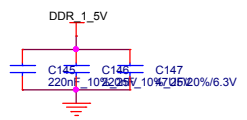
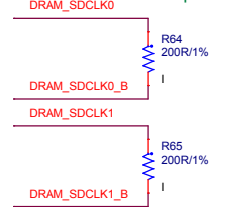

Design	<design>	Embest Tech Co. LTD		
Review	<review>			
Authorize	<authorize>	Title Mini9000		
Standardize	<standardize>	Size	Doc Name	Ver.
		A3	07 IMX6Q_SOC_C	X1
		Date	Tuesday, January 27, 2015	Sheet 7 of 13

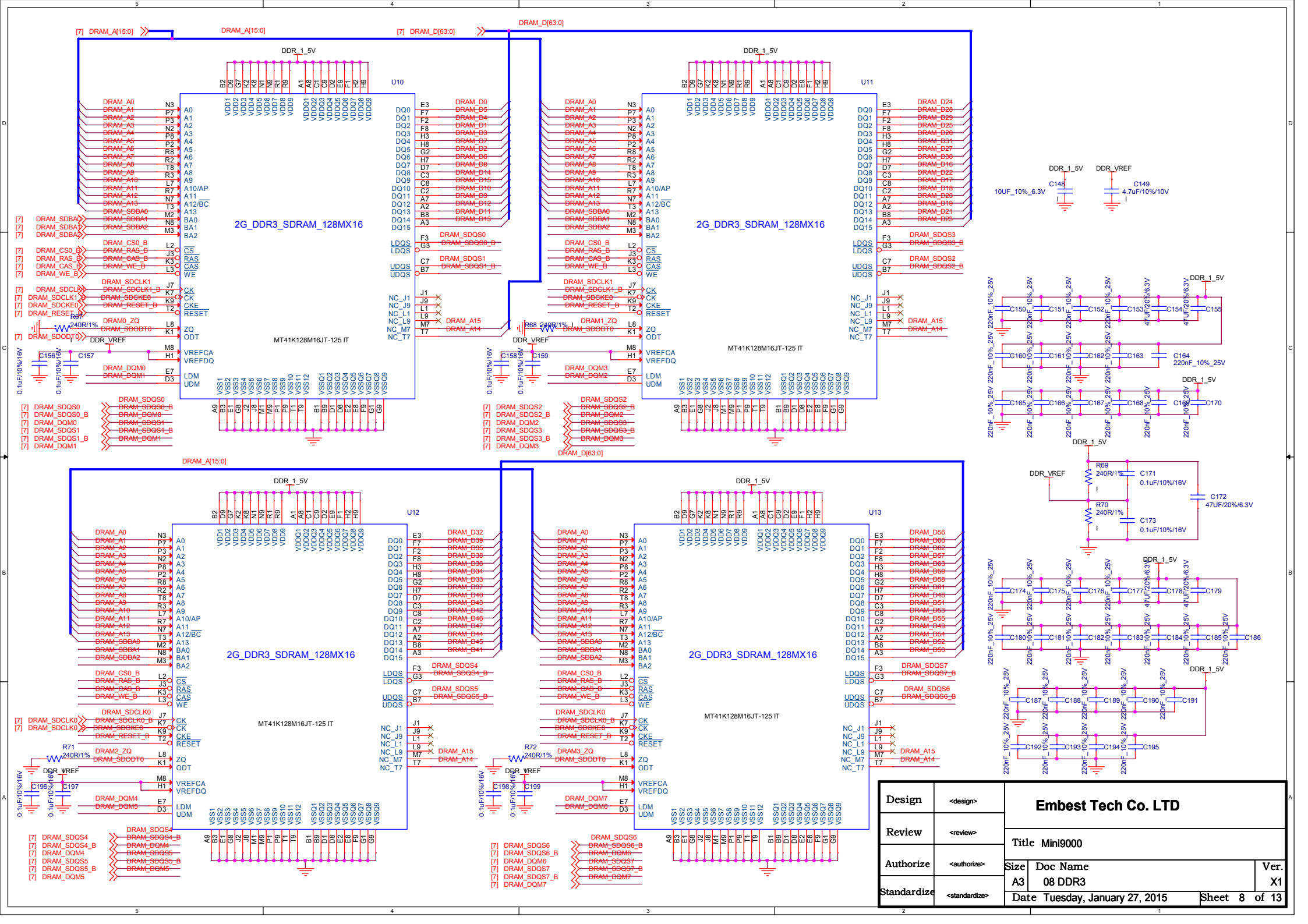

Design	<design>	Embest Tech Co. LTD			
Review	<review>				
Authorize	<authorize>	Title	Mini9000		
Standardize	<standardize>	Size	A3	Doc Name	08 DDR3
		Date	Tuesday, January 27, 2015	Sheet	8 of 13
				Ver.	X1

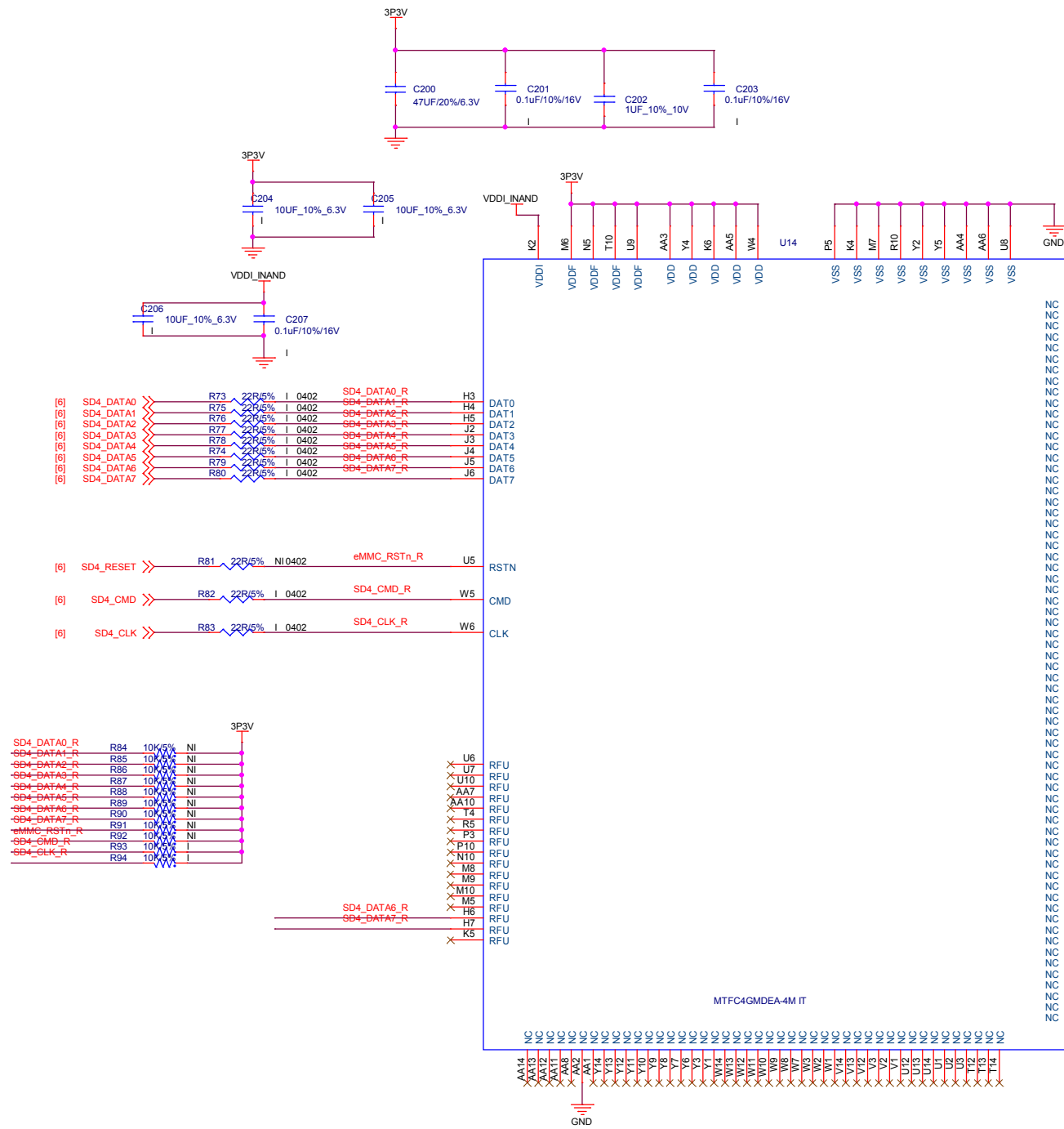

- NC D14
- NC D1
- NC B13
- NC B2
- NC A11
- NC A9
- NC A8
- NC A4
- NC H14
- NC H13
- NC H12
- NC H11
- NC H10
- NC H9
- NC H8
- NC H2
- NC H1
- NC J1
- NC J7
- NC J8
- NC J9
- NC J10
- NC J11
- NC J12
- NC J13
- NC J14
- NC K1
- NC K3
- NC K7
- NC K8
- NC K9
- NC K10
- NC K11
- NC K12
- NC K13
- NC K14
- NC L4
- NC L3
- NC L2
- NC L1
- NC L12
- NC L13
- NC L14
- NC M1
- NC M2
- NC M3
- NC M12
- NC M13
- NC M14
- NC N3
- NC N2
- NC N1
- NC P2
- NC P1
- NC P12
- NC P13
- NC P14
- NC R3
- NC R2
- NC R1
- NC R14
- NC R13
- NC R12
- NC T3
- NC T2
- NC T1

Design	<design>	Embest Tech Co. LTD		
Review	<review>			
Authorize	<authorize>	Size	Doc Name	Ver.
Standardize	<standardize>	A3	09 eMMC	X1
		Date	Tuesday, January 27, 2015	Sheet 9 of 13

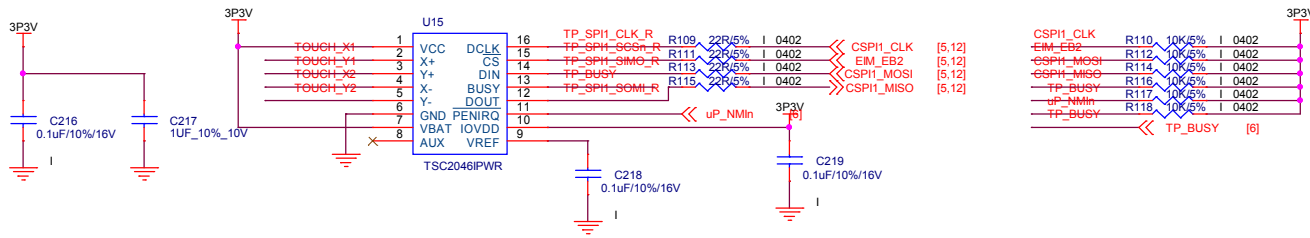
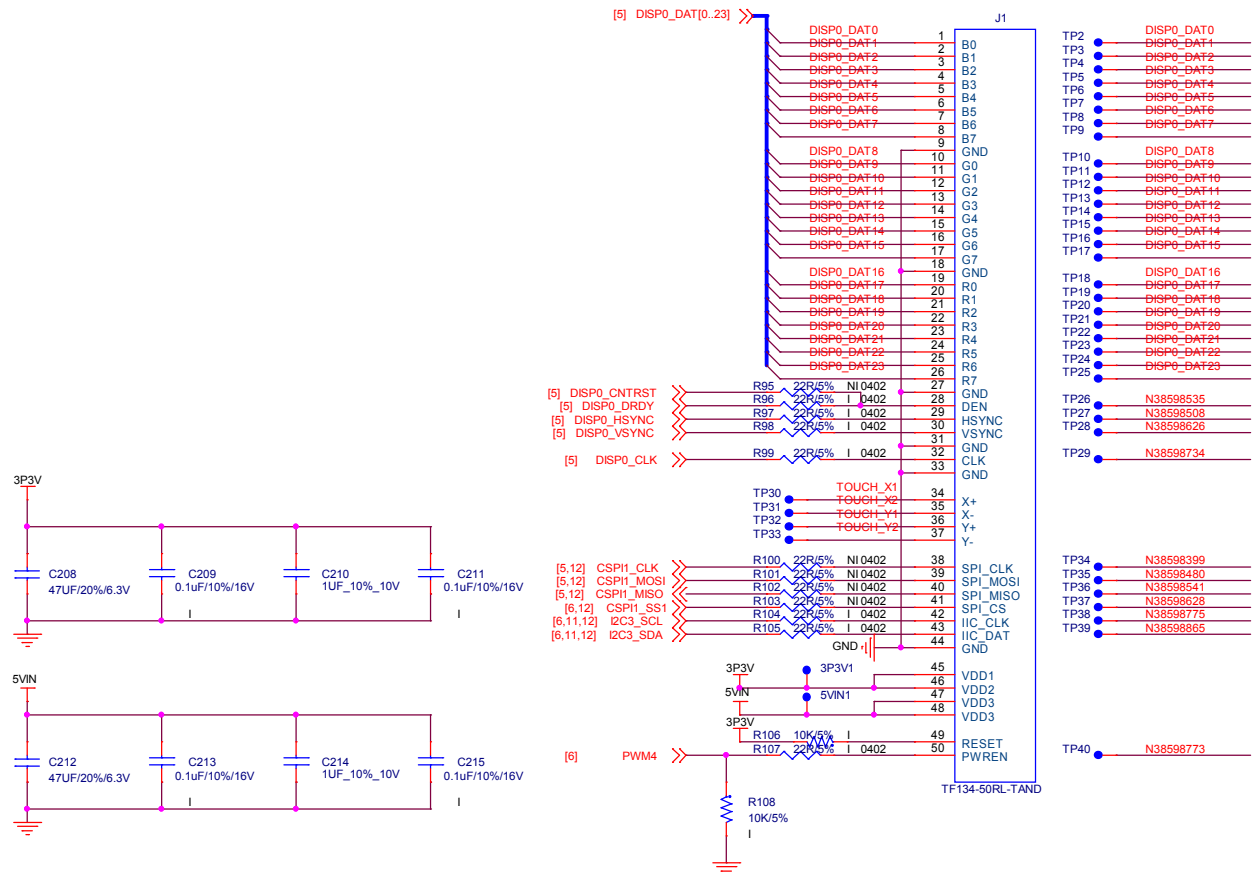

Design	<design>	Embust Tech Co. LTD		
Review	<review>			
Authorize	<authorize>	Title Mini9000		
Standardize	<standardize>	Size	Doc Name	Ver.
		A3	10 LCD	X1
		Date	Tuesday, January 27, 2015	Sheet 10 of 13

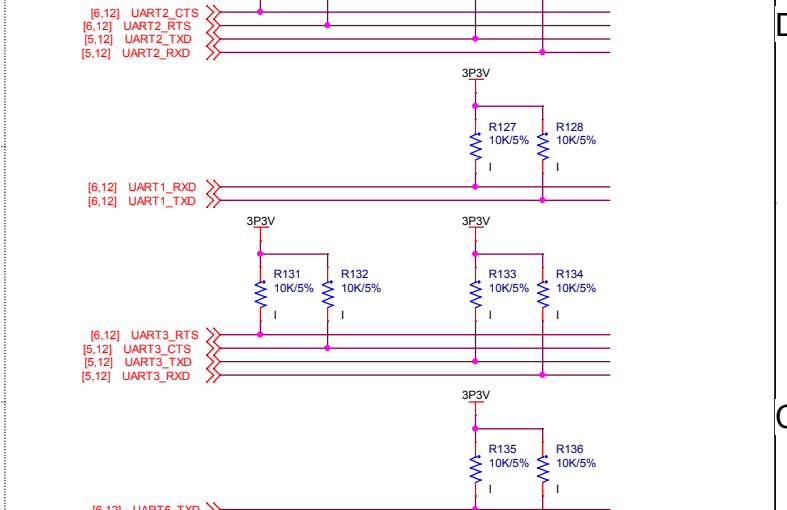
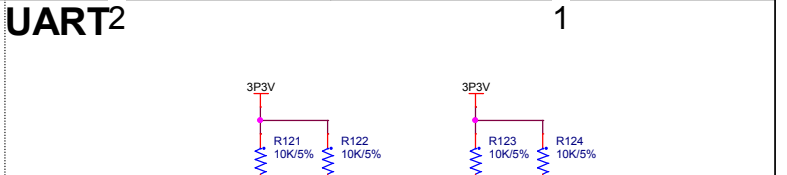
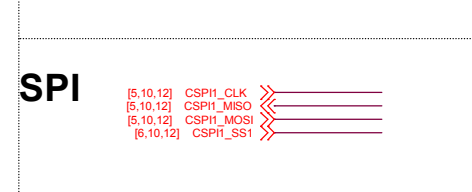
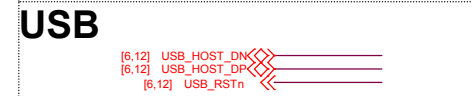
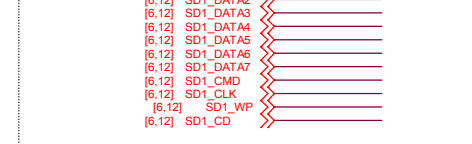
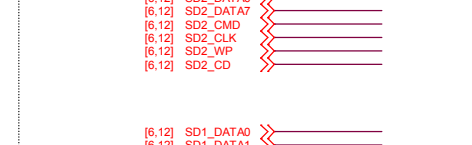
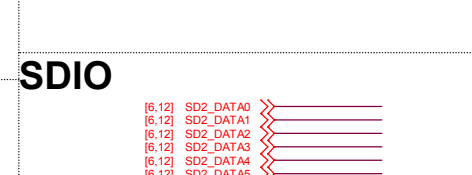
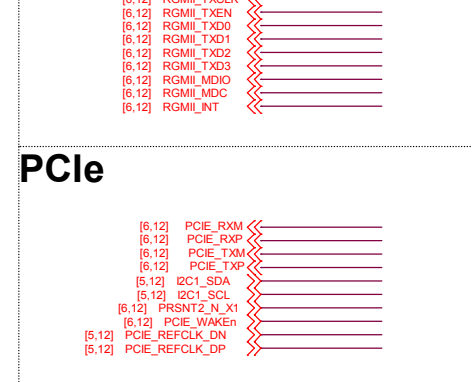
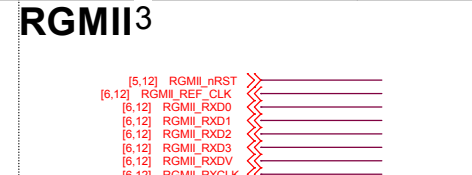
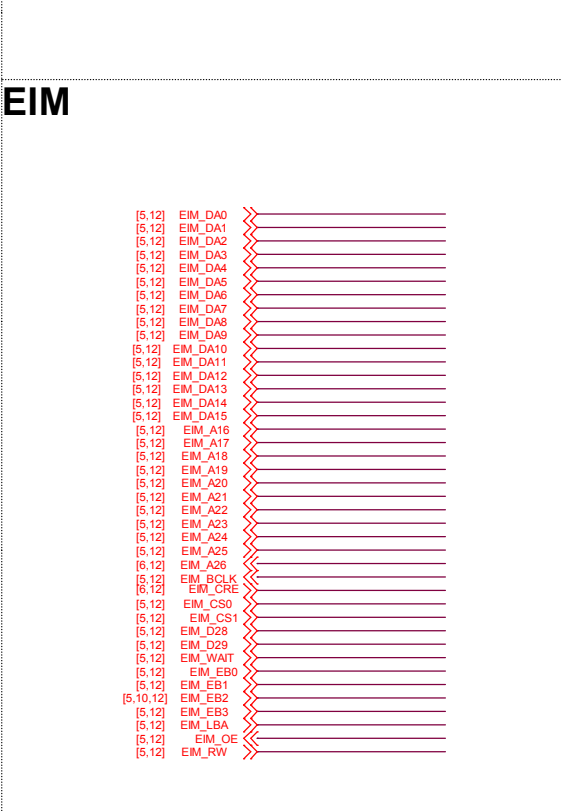
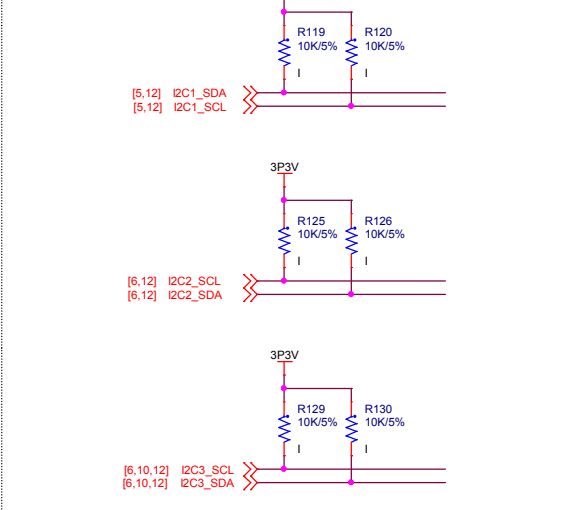
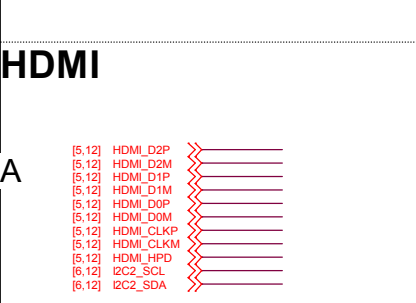
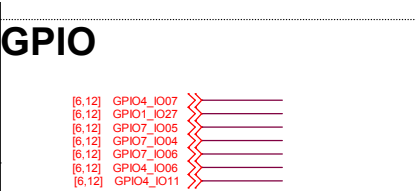
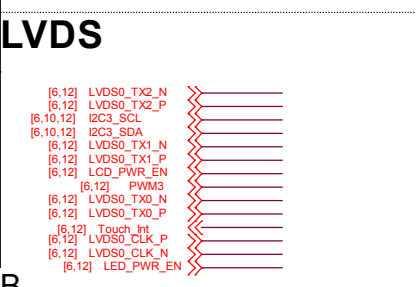
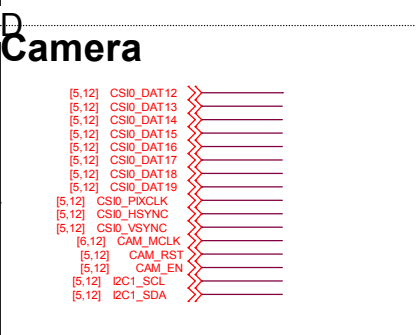
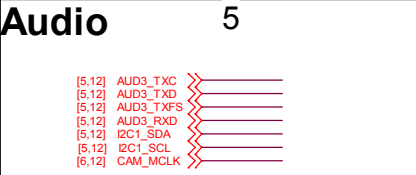

Design	<design>	Embest Tech Co. LTD		
Review	<review>			
Authorize	<authorize>	Title Mini9000		Ver.
Standardize	<standardize>	Size	Doc Name	X1
		A3	11 Signal Group & LEDs	
		Date	Tuesday, January 27, 2015	Sheet 11 of 13

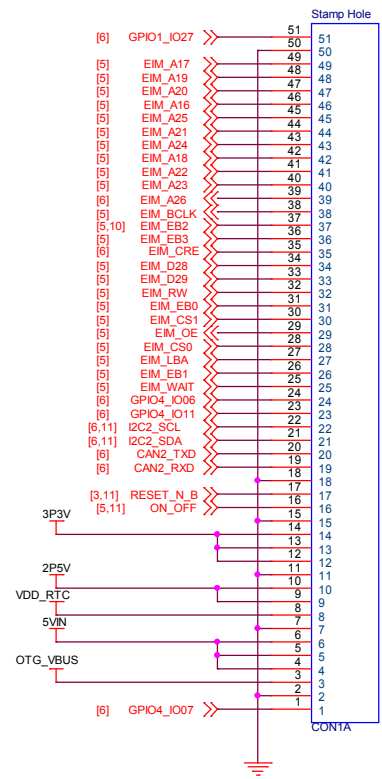

Fiducials

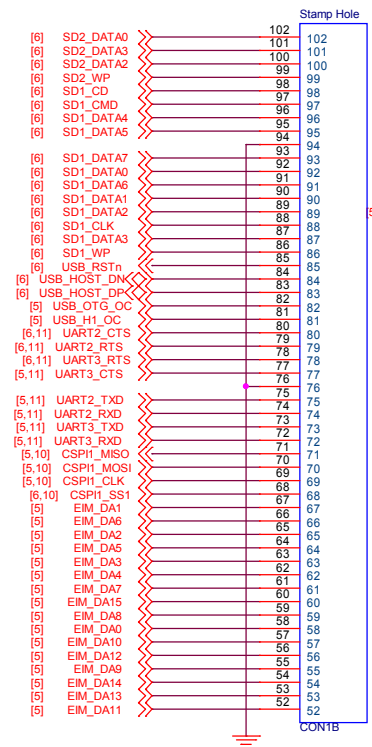

PCB

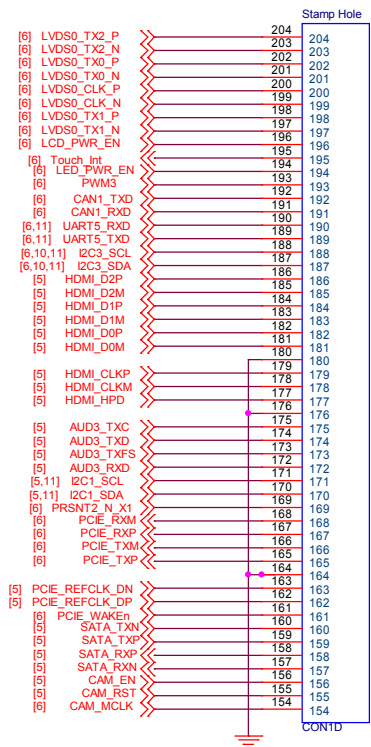
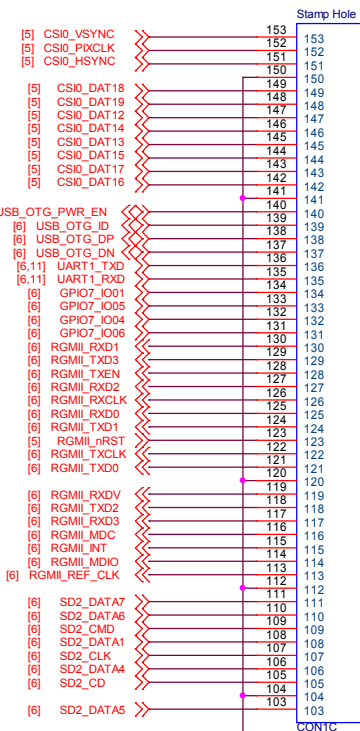

Design	<design>	Embest Tech Co. LTD		
Review	<review>			
Authorize	<authorize>	Size	Doc Name	Ver.
Standardize	<standardize>	A3	12 Mechanical	X1
		Date	Tuesday, January 27, 2015	Sheet 12 of 13

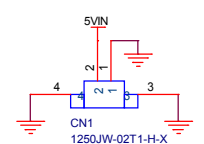
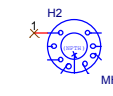
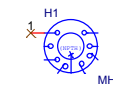
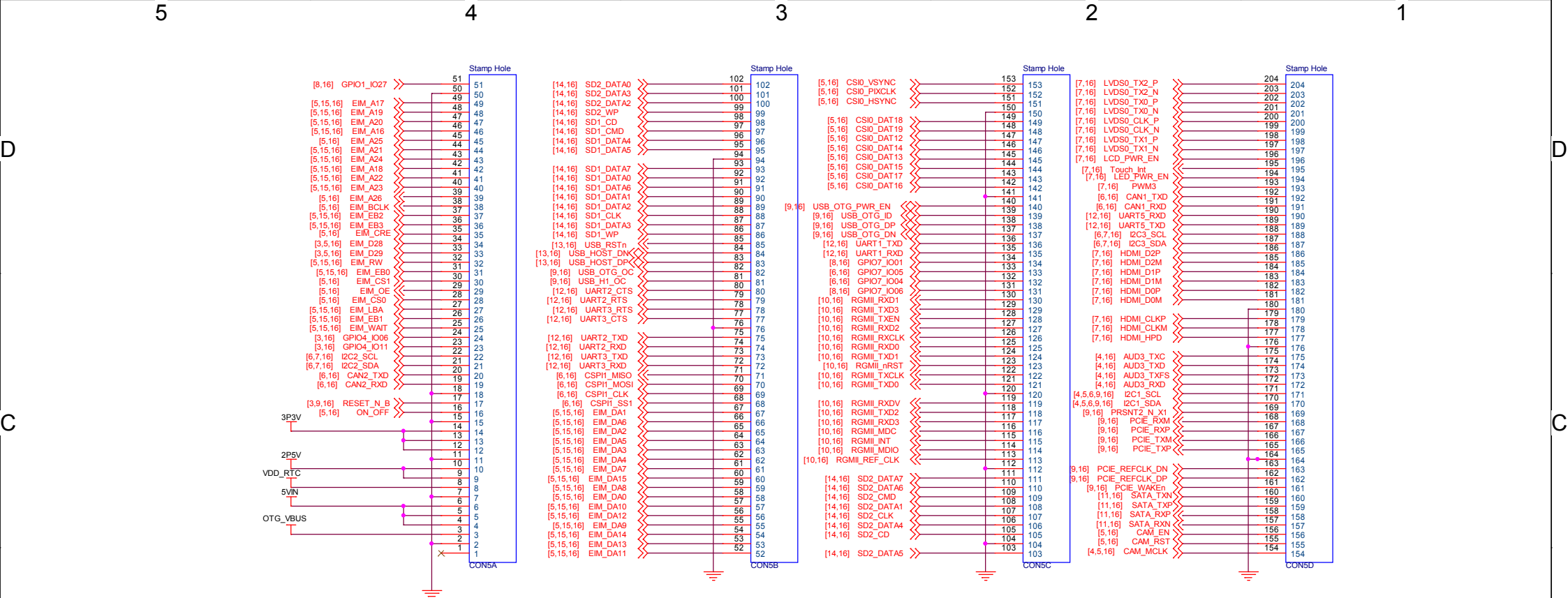

Design	<design>	Embest Tech Co. LTD		
Review	<review>			
Authorize	<authorize>	Title Mini9000		
Standardize	<standardize>	Size	Doc Name	Ver.
		A3	13 Package	X1
		Date	Tuesday, January 27, 2015	Sheet 13 of 13