

Schematic: SOM-PH8800

SHEET	SHEET NAME
01	Title/Revision History
02	Block Diagram
03	PMIC Power Supply
04	AM437X Power
05	AM437X System/USB
06	AM437X Bus Interface/ADC
07	DDR3 Memory
08	eMMC/Nand/QSPI/EEPROM
09	Ethernet 1/2
10	LCD/Camera/LED
11	Connector

Revision History

DATE	REVISION	DESCRIPTION
30 Mar 2016	1001001000454_SOM-PH8800 SCH Rev01_160330	Second Release
11 Apr 2016	1001001000454_SOM-PH8800 SCH Rev02_160411	Thrid Release

Change List:

1、 1001001000454_SOM-PH8800 SCH Rev02_160407

(1) Added R200=R201=NI(0R) .

(2) Changed R155=NI(10K) to R155=100K, and pull up to pull down.

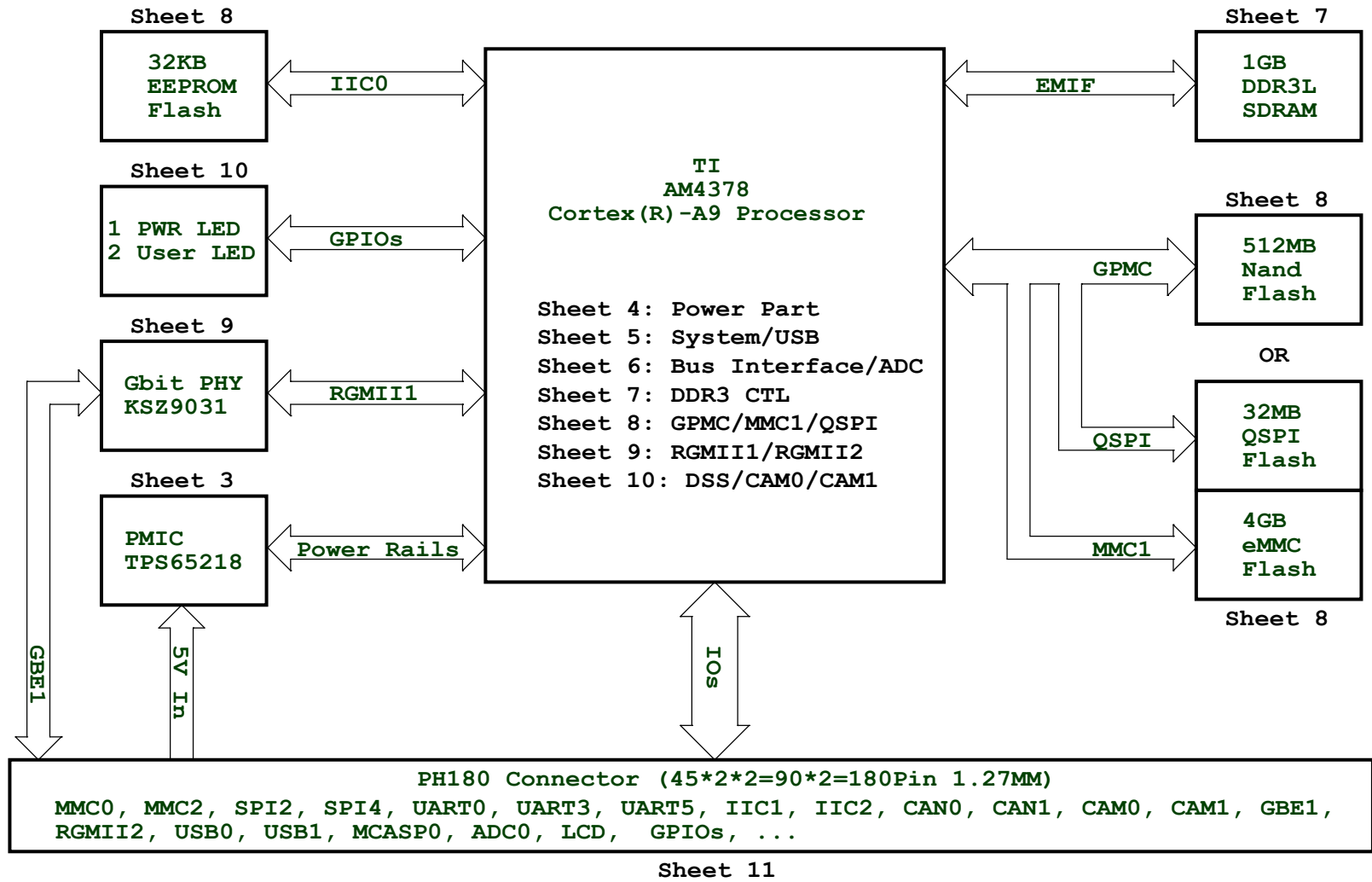

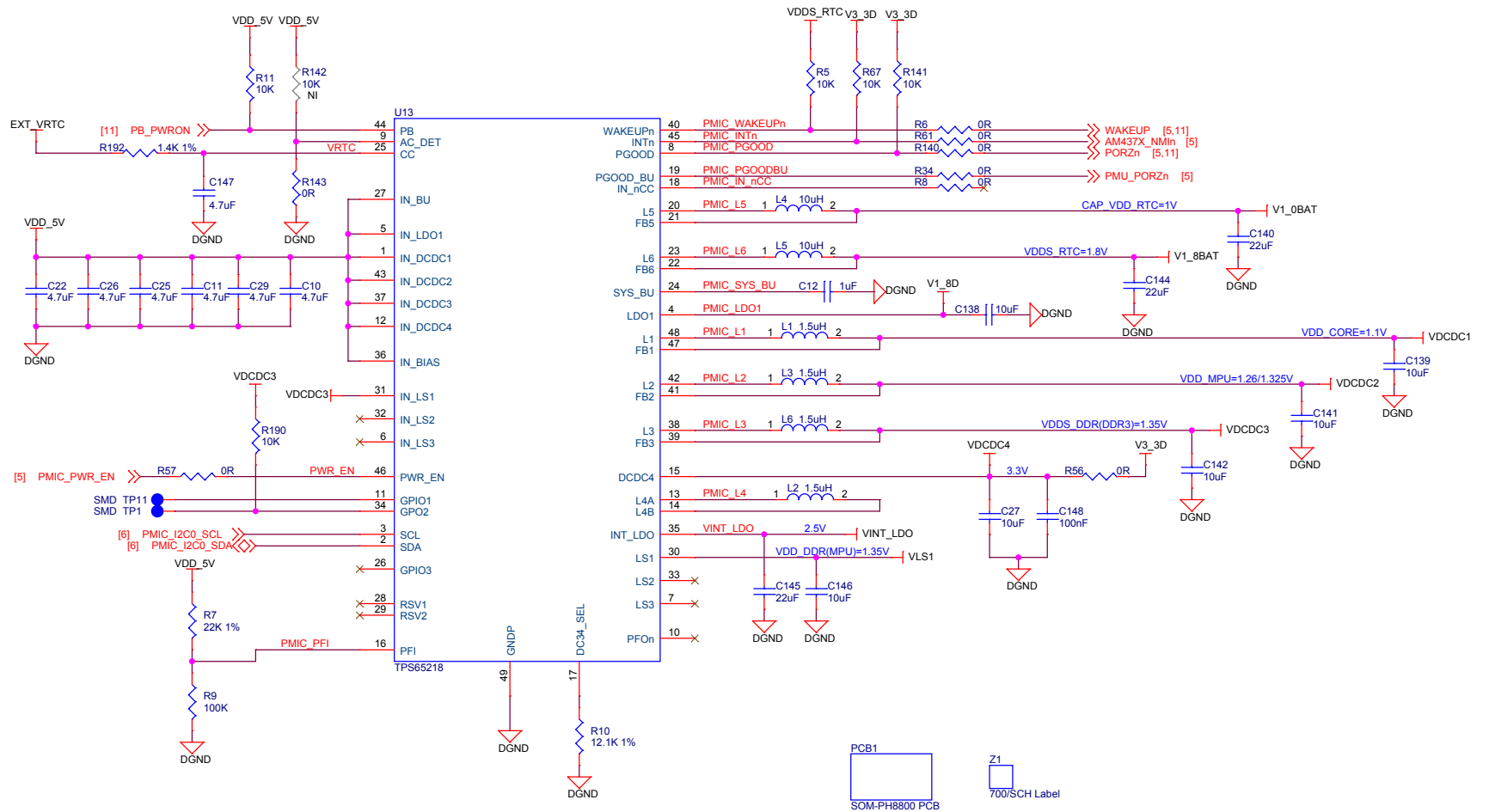

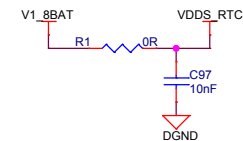
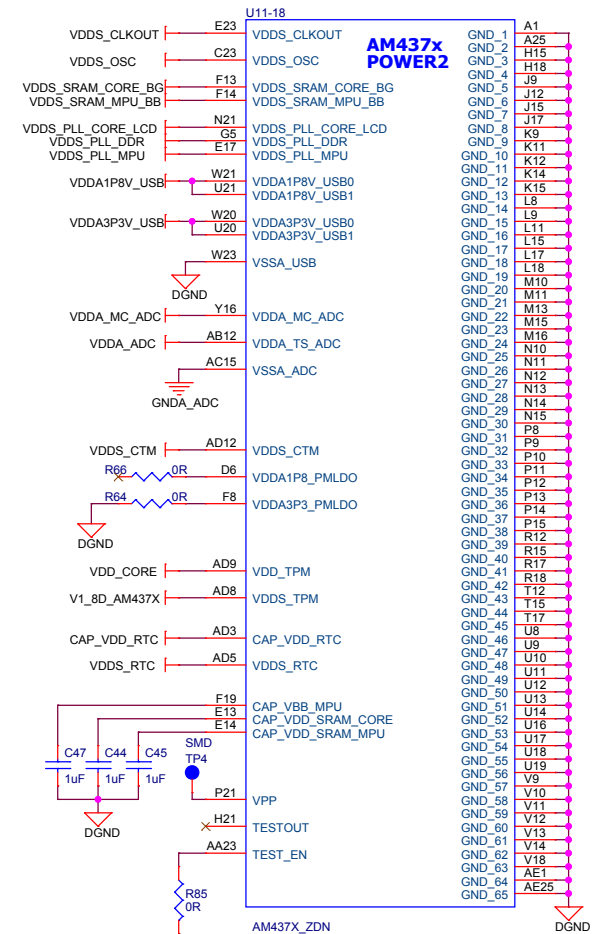
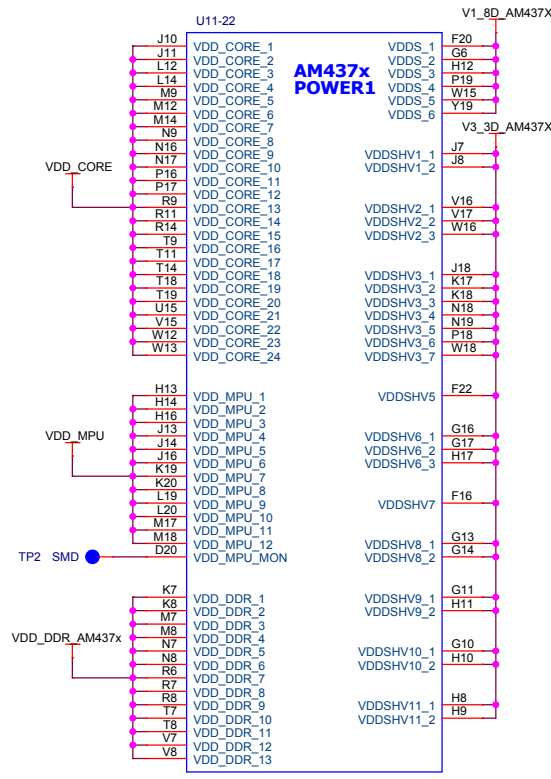
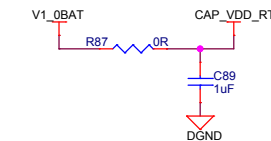
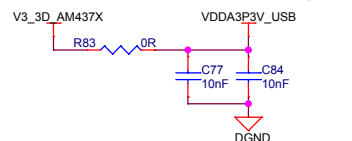
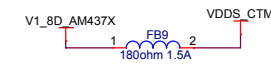
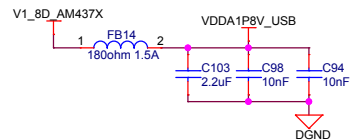
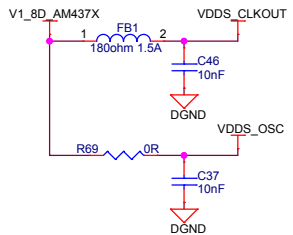
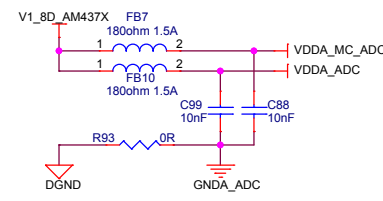
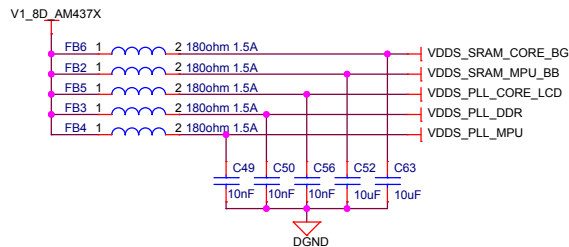
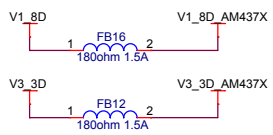
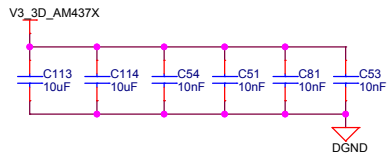
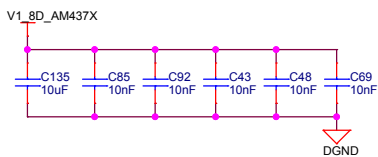
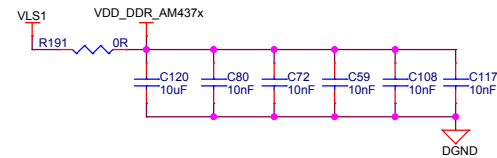
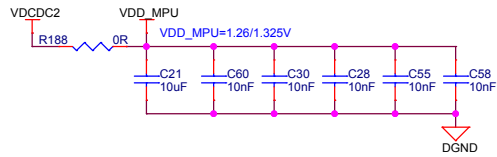
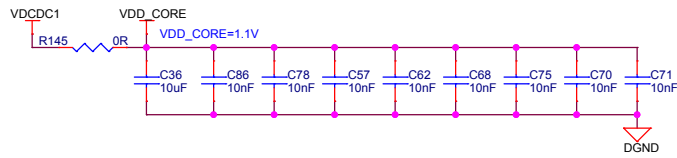

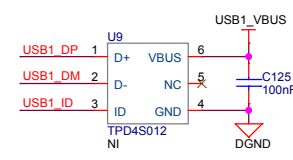
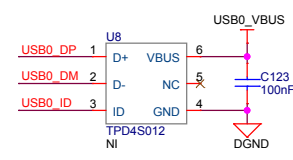
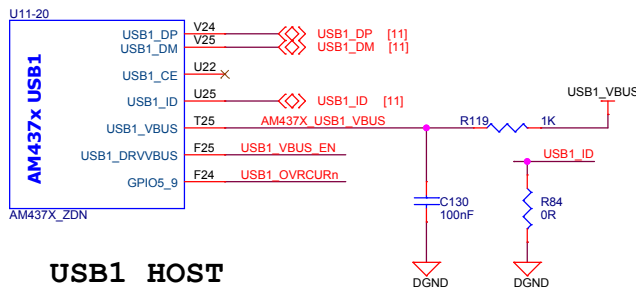
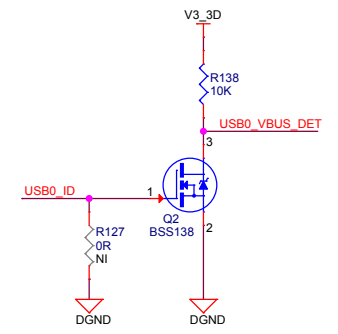
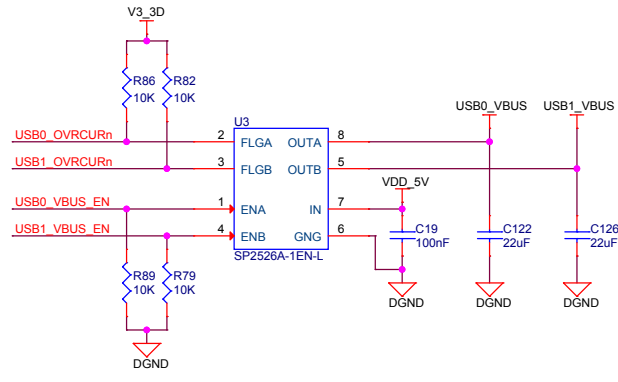
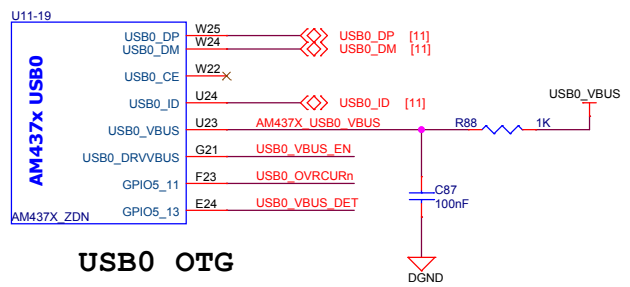
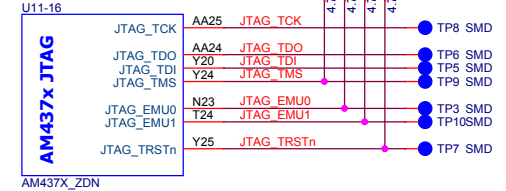
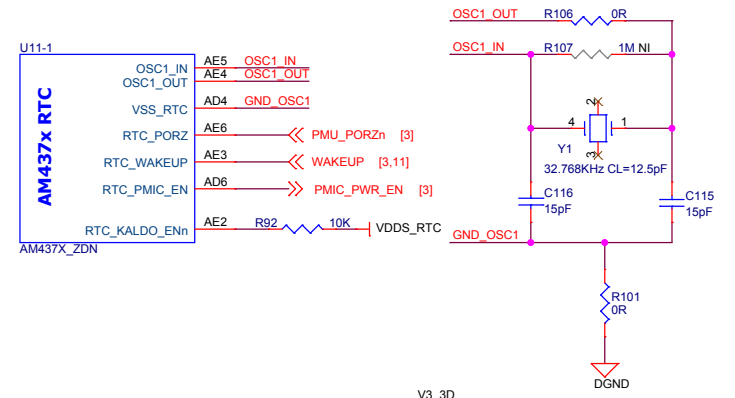
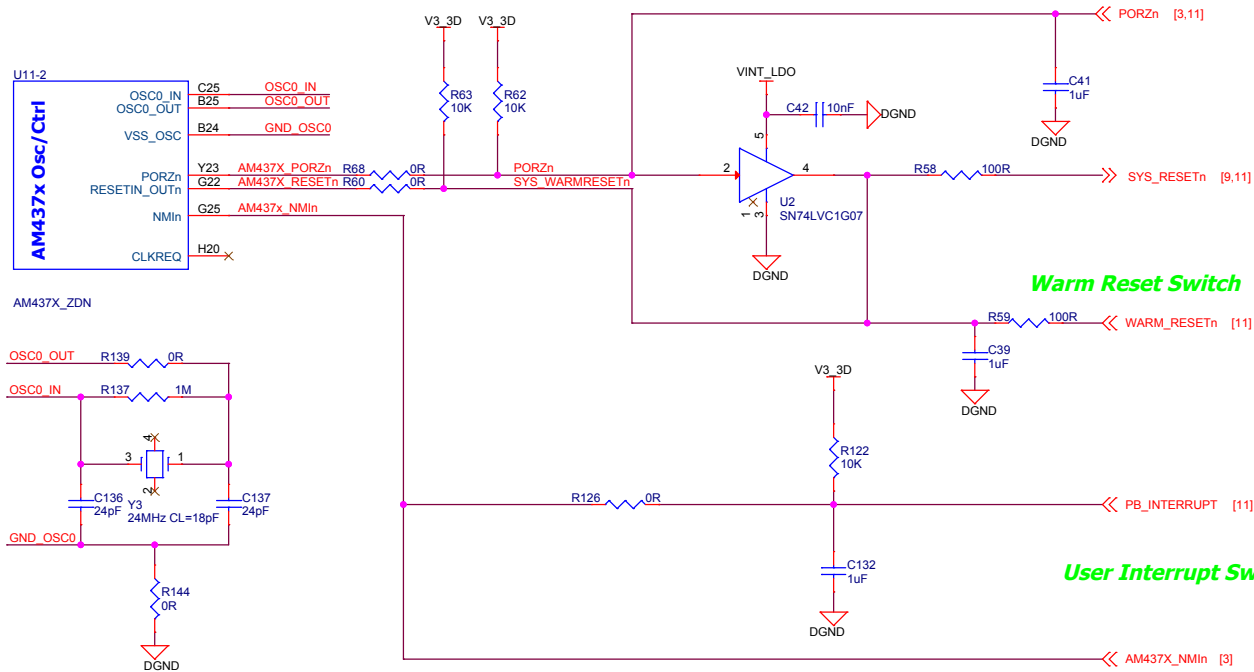

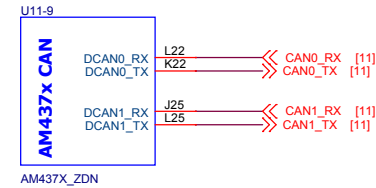
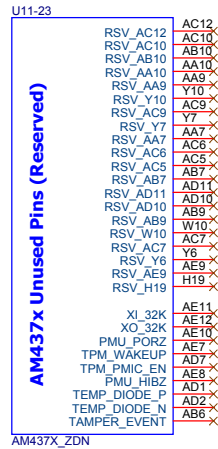
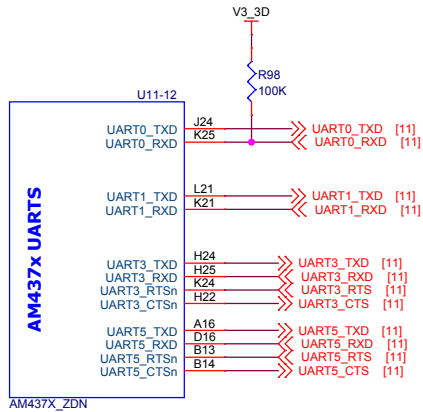
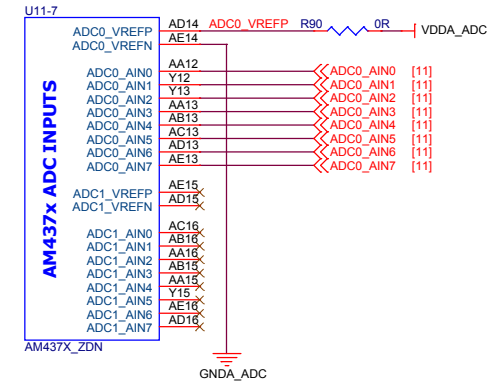
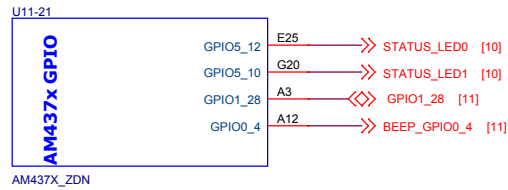
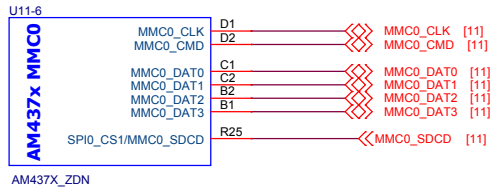
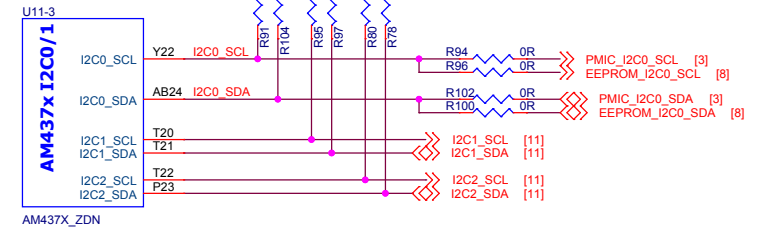
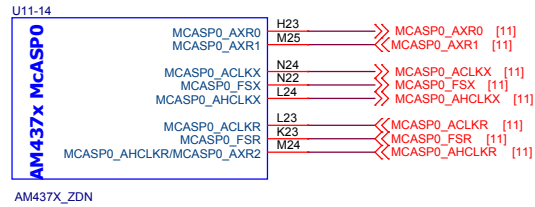
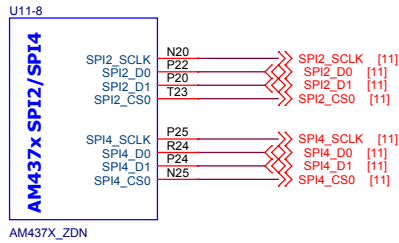

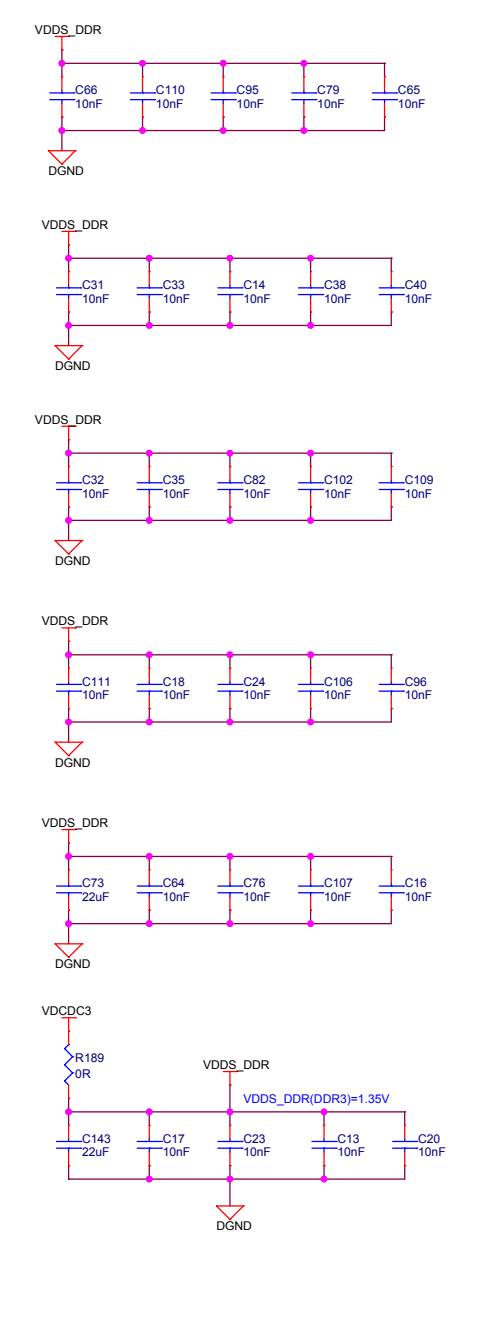
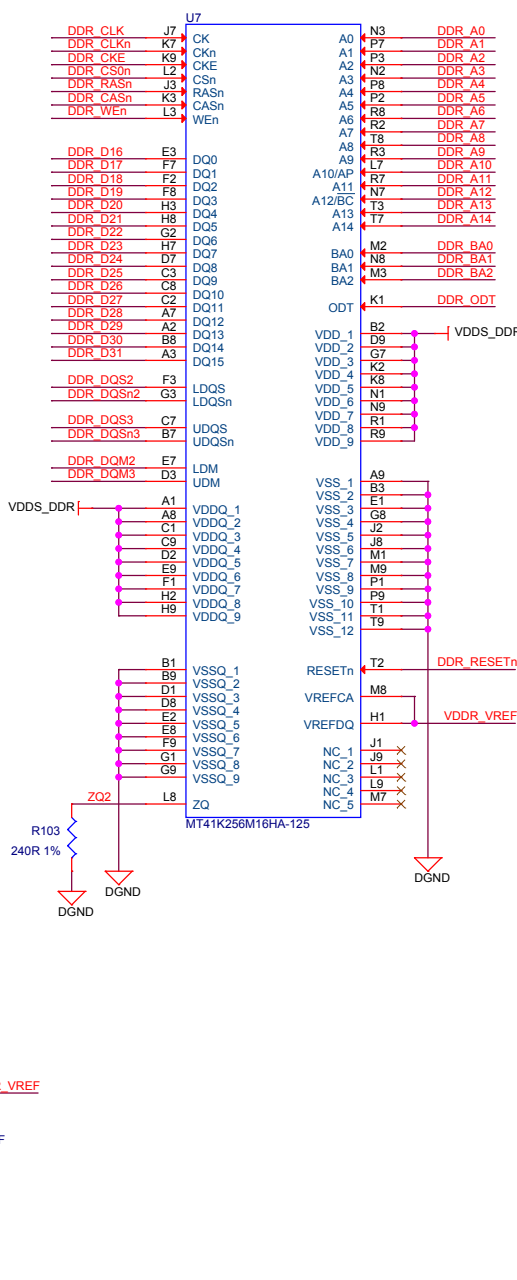
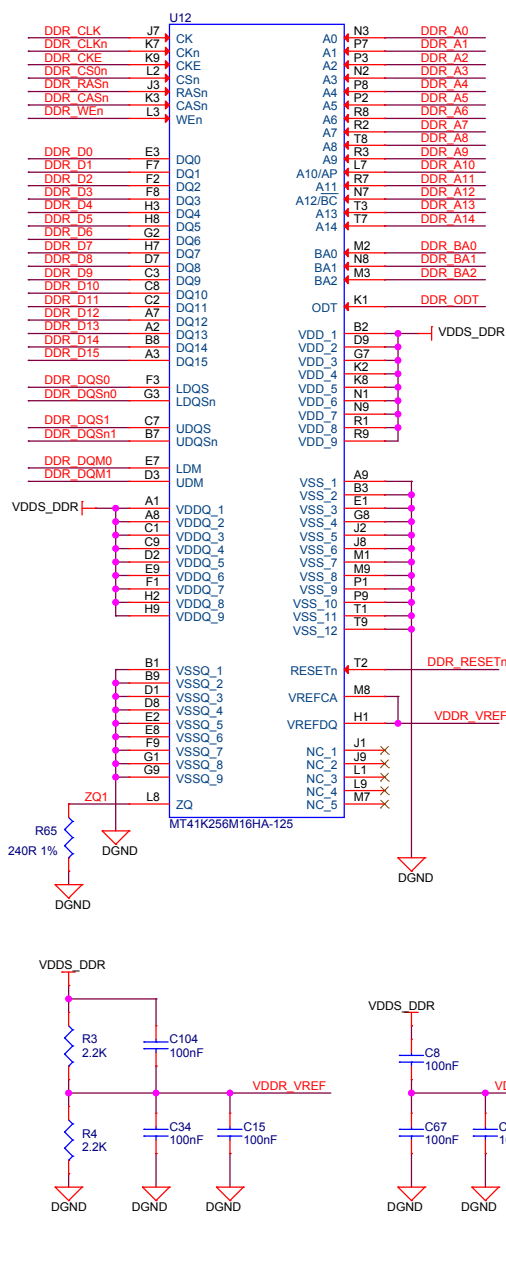
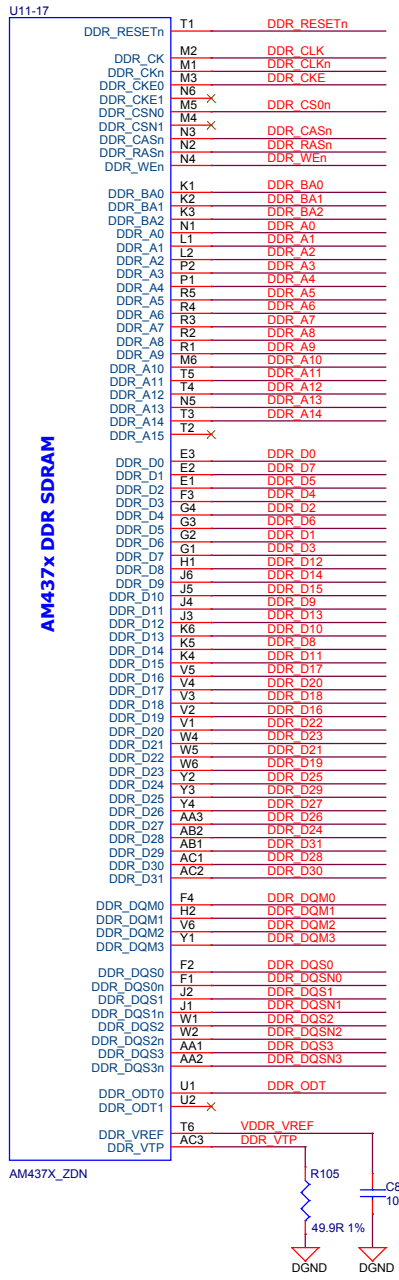

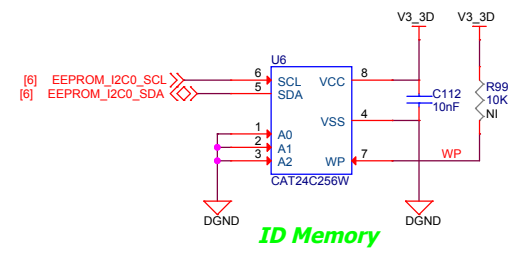
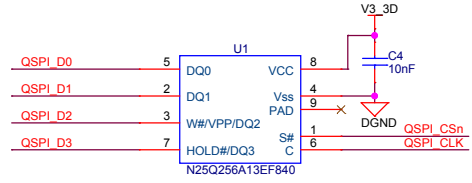
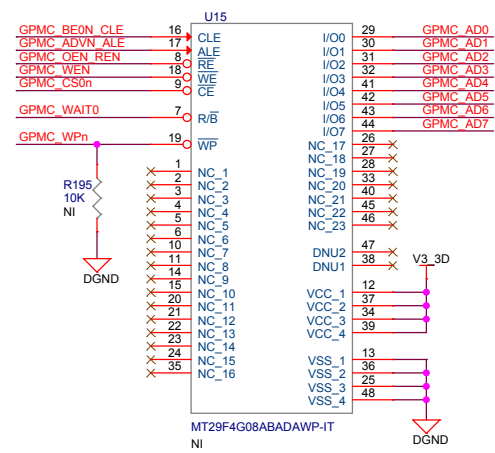
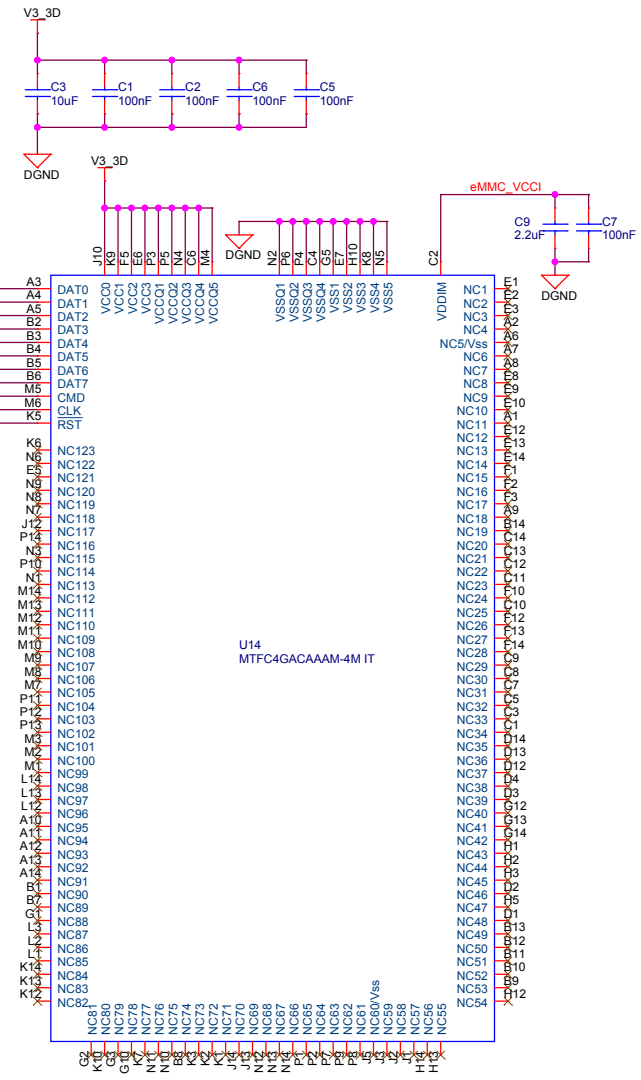
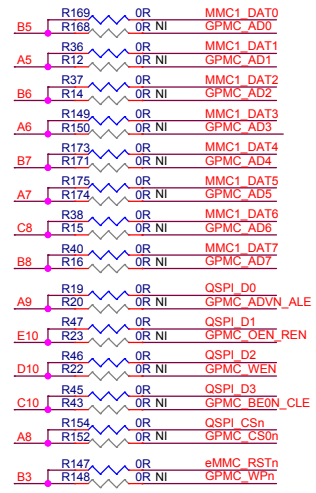
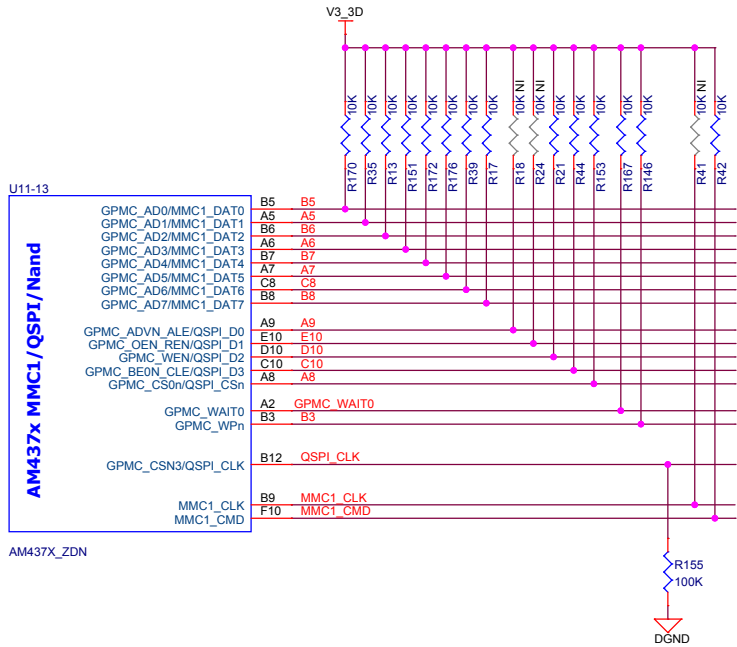

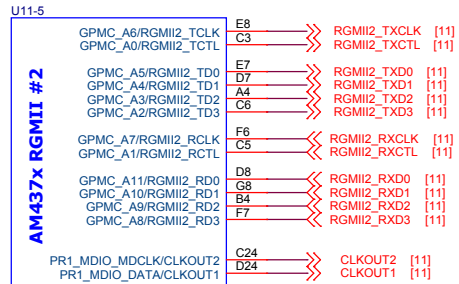

AM437X_ZDN

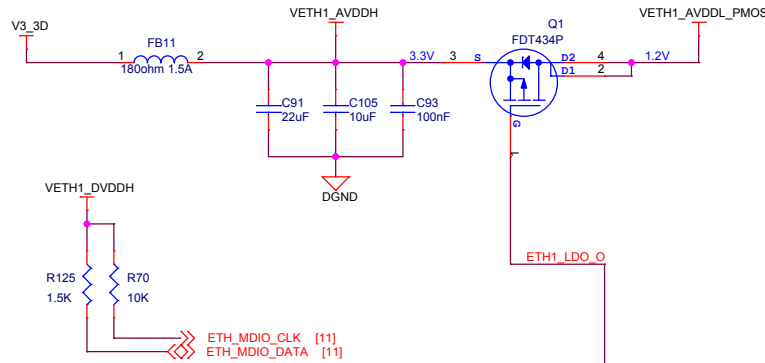

Strapping Options:

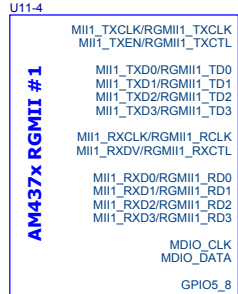
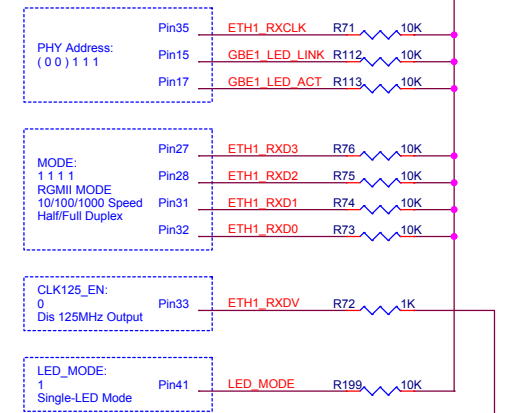

AM437X_ZDN

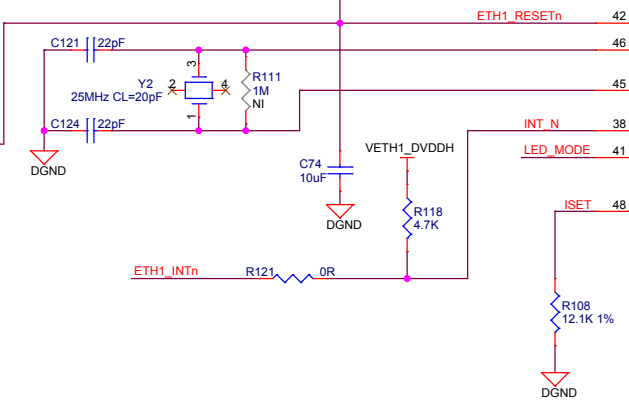
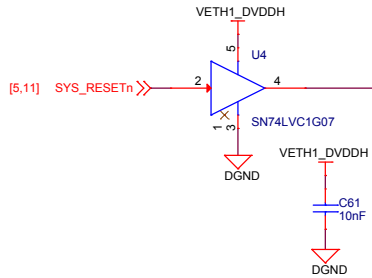
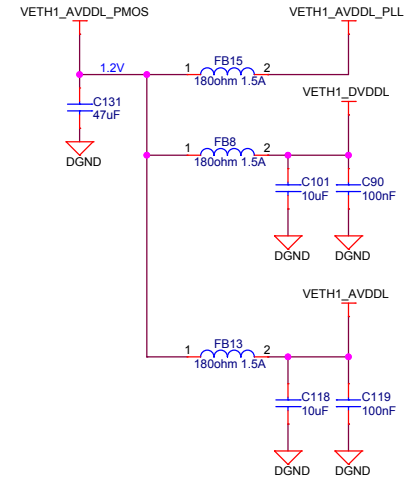
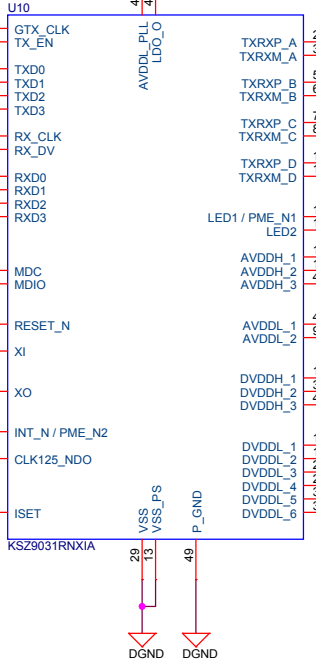
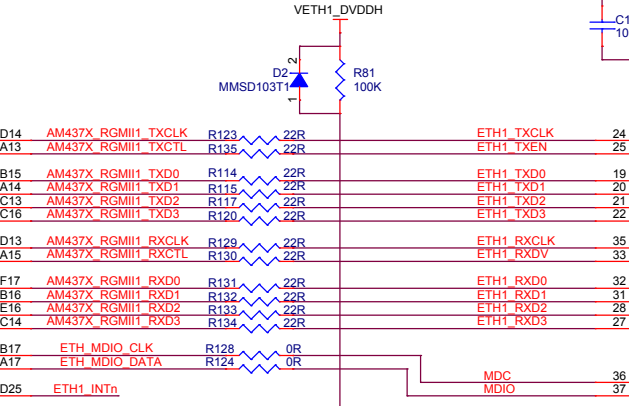

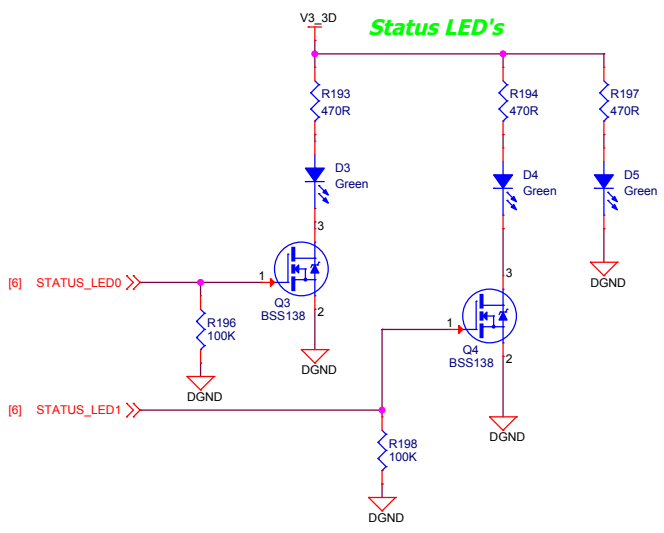
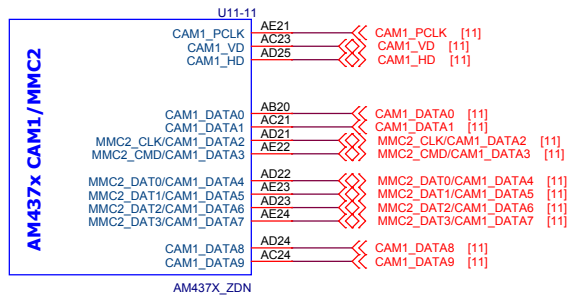
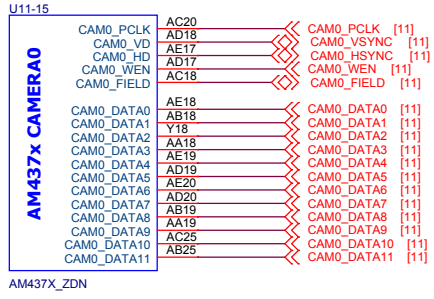
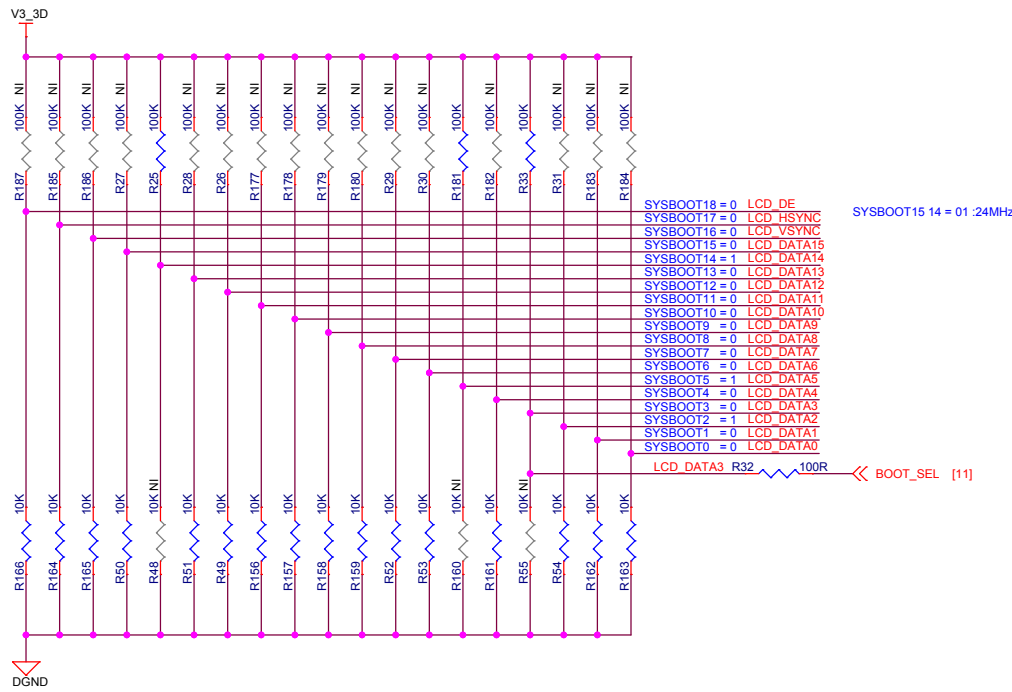
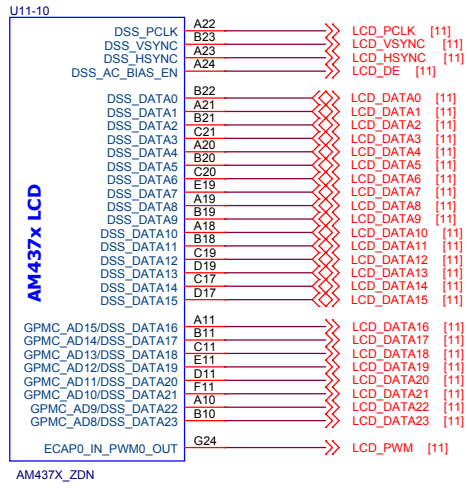

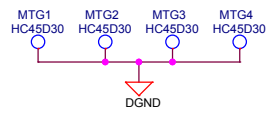
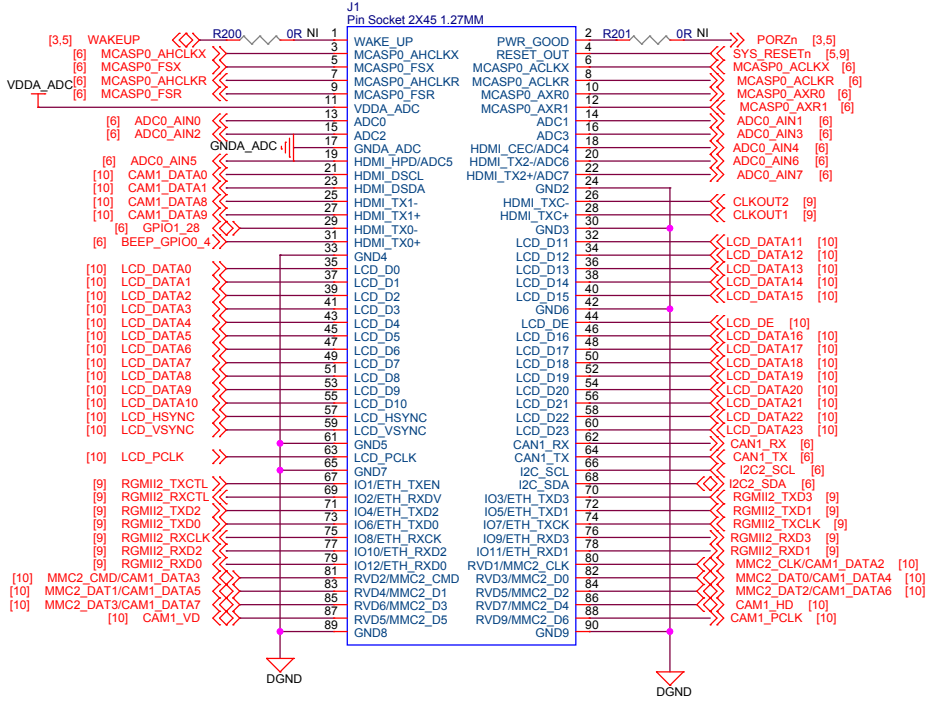
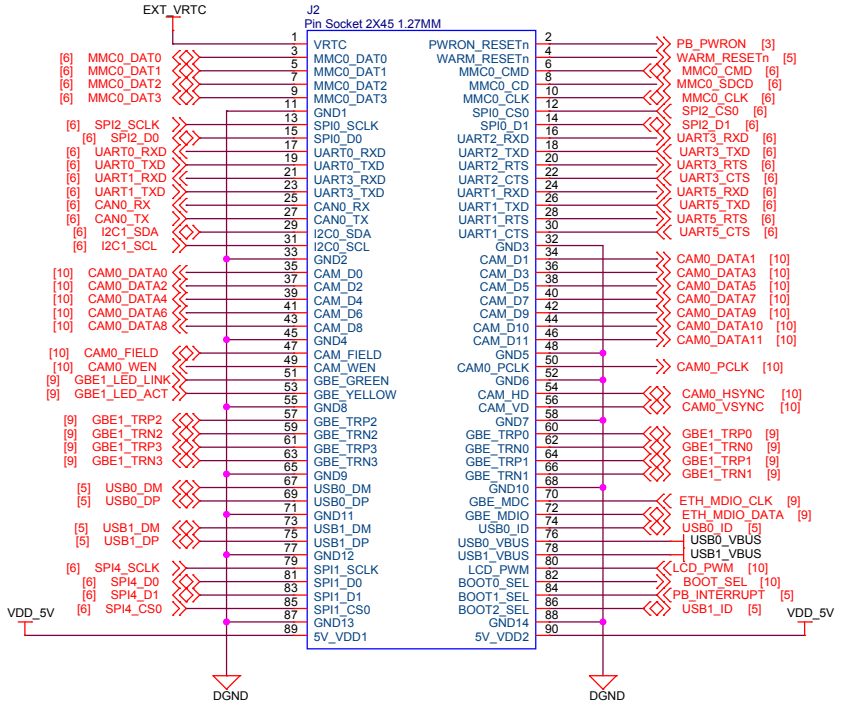

embest <http://www.embest-tech.com>

Title: **SOM-PH8800**

Size: A3	Document Number: 11 Connector	Rev: Rev02
Draw By: XlnJQ	Date: Wednesday, April 06, 2016	Sheet: 11 of 11